



TEST REPORT

Reference No...... : WTX23X08183427E001
Applicant : GlobTek, Inc.
Address : 186 Veterans Dr. Northvale, NJ 07647 USA
Manufacturer : 1: GlobTek, Inc. 2: GlobTek (Suzhou) Co., Ltd
1: 186 Veterans Dr. Northvale, NJ 07647 USA
Address : 2: Building 4, No. 76, Jin Ling East Rd., Suzhou Industrial Park, Suzhou,
JiangSu 215021, China
Product Name : X-plore 8000 Standard Charger
Model No...... : R59780
Standards..... : **EN 55032:2015+A1:2020**
EN 55035:2017+A11:2020
EN IEC 61000-3-2:2019+A1:2021
EN 61000-3-3:2013+A2:2021
Date of Receipt sample : 2023-08-25
Date of Test..... : 2023-08-25 to 2023-09-04
Date of Issue : 2023-09-06
Test Report Form No. : WTX_EN 55032_2015_B
Test Result..... : **Pass**

Remarks:

The results shown in this test report refer only to the sample(s) tested, this test report cannot be reproduced, except in full, without prior written permission of the company. The report would be invalid without specific stamp of test institute and the signatures of approver.

Prepared By:

Waltek Testing Group (Shenzhen) Co., Ltd.

Address: 1/F., Room 101, Building 1, Hongwei Industrial Park, Liuxian 2nd Road,
Block 70 Bao'an District, Shenzhen, Guangdong, China
Tel.: +86-755-33663308 Fax.: +86-755-33663309 Email: sem@waltek.com.cn

Tested by:

Tom Ma

Tom Ma

Approved by:

Silin Chen

Silin Chen



TABLE OF CONTENTS

1. GENERAL INFORMATION	5
1.1 PRODUCT DESCRIPTION FOR EQUIPMENT UNDER TEST (EUT)	5
1.2 TEST STANDARDS.....	6
1.3 TEST METHODOLOGY	6
1.4 EUT SETUP AND OPERATION MODE	7
1.5 PERFORMANCE CRITERIA FOR EMS.....	7
1.6 TEST EQUIPMENT LIST AND DETAILS	8
2. SUMMARY OF TEST RESULTS	10
3. CONDUCTED EMISSION	11
3.1 MEASUREMENT UNCERTAINTY	11
3.2 BASIC TEST SETUP BLOCK DIAGRAM	11
3.3 ENVIRONMENTAL CONDITIONS.....	11
3.4 SUMMARY OF TEST RESULTS.....	11
4. RADIATED EMISSION	16
4.1 MEASUREMENT UNCERTAINTY	16
4.2 BASIC TEST SETUP BLOCK DIAGRAM	16
4.3 CORRECTED AMPLITUDE & MARGIN CALCULATION.....	17
4.4 ENVIRONMENTAL CONDITIONS	17
4.5 SUMMARY OF TEST RESULTS.....	17
5. HARMONIC CURRENT EMISSIONS	22
5.1 TEST PROCEDURE	22
5.2 TEST STANDARDS	22
5.3 ENVIRONMENTAL CONDITIONS	22
5.4 BASIC TEST SETUP BLOCK DIAGRAM	22
5.5 HARMONIC CURRENT EMISSIONS TEST DATA.....	22
6. VOLTAGE FLUCTUATION FLICKER	23
6.1 TEST PROCEDURE	23
6.2 TEST STANDARDS	23
6.3 ENVIRONMENTAL CONDITIONS	23
6.4 BASIC TEST SETUP BLOCK DIAGRAM	23
6.5 VOLTAGE FLUCTUATION AND FLICKER TEST DATA.....	23
7. ELECTROSTATIC DISCHARGES (ESD)	25
7.1 TEST PROCEDURE	25
7.2 TEST PERFORMANCE.....	25
7.3 ENVIRONMENTAL CONDITIONS	25
7.4 BASIC TEST SETUP BLOCK DIAGRAM	25
7.5 ELECTROSTATIC DISCHARGE IMMUNITY TEST DATA	26
8. CONTINUOUS RF ELECTROMAGNETIC FIELD DISTURBANCES (RS)	27
8.1 TEST PROCEDURE	27
8.2 TEST PERFORMANCE.....	27
8.3 ENVIRONMENTAL CONDITIONS	27
8.4 BASIC TEST SETUP BLOCK DIAGRAM	27
8.5 CONTINUOUS RADIATED DISTURBANCES TEST DATA.....	28
9. ELECTRICAL FAST TRANSIENTS (EFT)	29
9.1 TEST PROCEDURE	29
9.2 TEST PERFORMANCE.....	29
9.3 ENVIRONMENTAL CONDITIONS	29
9.4 BASIC TEST SETUP BLOCK DIAGRAM	29
9.5 ELECTRICAL FAST TRANSIENTS TEST DATA.....	30
10. SURGES	31
10.1 TEST PROCEDURE	31
10.2 TEST PERFORMANCE	31



Reference No.: WTX23X08183427E001

10.3 ENVIRONMENTAL CONDITIONS	31
10.4 BASIC TEST SETUP BLOCK DIAGRAM	31
10.5 SURGE TEST DATA	32
11. CONTINUOUS INDUCED RF DISTURBANCES (C/S).....	33
11.1 TEST PROCEDURE	33
11.2 TEST PERFORMANCE	33
11.3 ENVIRONMENTAL CONDITIONS	33
11.4 BASIC TEST SETUP BLOCK DIAGRAM.....	33
11.5 CONTINUOUS CONDUCTED DISTURBANCES TEST DATA.....	34
12. POWER-FREQUENCY MAGNETIC FIELDS (PFMF).....	35
12.1 TEST PROCEDURE	35
12.2 TEST PERFORMANCE	35
12.3 ENVIRONMENTAL CONDITIONS	35
12.4 BASIC TEST SETUP BLOCK DIAGRAM	35
12.5 POWER-FREQUENCY MAGNETIC FIELD TEST DATA	35
13. VOLTAGE DIPS AND INTERRUPTIONS.....	36
13.1 TEST PROCEDURE	36
13.2 TEST PERFORMANCE	36
13.3 ENVIRONMENTAL CONDITIONS	36
13.4 BASIC TEST SETUP BLOCK DIAGRAM	36
13.5 VOLTAGE DIPS AND INTERRUPTIONS TEST DATA	36
EXHIBIT 1 - PRODUCT LABELING.....	37
PROPOSED CE LABEL FORMAT	37
PROPOSED LABEL LOCATION ON EUT	37
EXHIBIT 2 - EUT PHOTOGRAPHS	38
EXHIBIT 3 - TEST SETUP PHOTOGRAPHS.....	46





Report version

Version No.	Date of issue	Description
Rev.00	2023-09-06	Original
/	/	/

WALTEK



1. GENERAL INFORMATION

1.1 Product Description for Equipment Under Test (EUT)

General Description of EUT	
Product Name:	X-plore 8000 Standard Charger
Trade Name:	Dräger or 
Model No.:	R59780
Adding Model(s):	GT-93036SHG3380
<p><i>Note: The test data is gathered from a production sample, provided by the manufacturer. The appearance of others models listed in the report is different from main-test model R59780, but the circuit and the electronic construction do not change, declared by the manufacturer.</i></p>	

Technical Characteristics of EUT	
Rated Voltage:	100-240V~, 50-60Hz
Rated Current:	/
Rated Power:	/
Power Adaptor Model:	GTM96600-6016-R2 Input: 100-240V~, 50-60Hz, 1.5A Output: 16.0V--3.75A 60.0W
Highest Internal Frequency:	Below 108MHz
Classification of Equipment:	Class B



1.2 Test Standards

The tests were performed according to following standards:

EN 55032:2015+A1:2020:Electromagnetic compatibility of multimedia equipment - Emission requirements.

EN 55035:2017+A11:2020:Electromagnetic compatibility of multimedia equipment - Immunity requirements.

EN IEC 61000-3-2:2019+A1:2021:Electromagnetic compatibility (EMC) -- Part 3-2: Limits - Limits for harmonic current emissions (equipment input current up to and including 16 A per phase).

EN 61000-3-3:2013+A2:2021:Electromagnetic compatibility (EMC) -- Part 3-3: Limits - Limitation of voltage changes, voltage fluctuations and flicker in public low-voltage supply systems, for equipment with rated current ≤ 16 A per phase and not subject to conditional connection.

Maintenance of compliance is the responsibility of the manufacturer. Any modification of the product maybe which result in lowering the emission/immunity should be checked to ensure compliance has been maintained.

1.3 Test Methodology

All measurements contained in this report were conducted with the standards EN 55032, EN IEC 61000-3-2, EN 61000-3-3 and EN 55035 for electromagnetic compatibility of multimedia equipment, and all related testing and measurement techniques intentional standards.



1.4 EUT Setup and Operation Mode

The equipment under test (EUT) was configured to measure its highest possible emission/immunity level. The test modes were adapted according to the operation manual for use, more detailed description as follows:

Test Mode List			
Test Mode	Description	Remark	Power Supply Mode
TM1	Working mode	/	AC 230V/50Hz
TM2	Working mode	/	AC 120V/60Hz

EUT Cable List and Details				
Cable Description	Length (m)	Shielded/Unshielded	With / Without Ferrite	With / Without Chip
DC Cable	1.7	Shielded	With	Without

Special Cable List and Details				
Cable Description	Length (m)	Shielded/Unshielded	With / Without Ferrite	With / Without Chip
/	/	/	/	/

Auxiliary Equipment List and Details			
Description	Manufacturer	Model	Serial Number
Battery	/	ARSC-0107	/

1.5 Performance Criteria for EMS

All the test data has been collected, reduced, and analyzed within this report in accordance with Immunity requires the following as specific performance criteria:

- A. The apparatus shall continue to operate as intended during and after the test. The manufacturer specifies some minimum performance level. The performance level may be specified by the manufacturer as a permissible loss of performance.
- B. The apparatus shall continue to operate as intended after the test. This indicates that the EUT does not need to function at normal performance levels during the test, but must recover. Again some minimal performance is defined by the manufacturer. No change in operating state or loss of data is permitted.
- C. Temporary loss of function is allowed. Operation of the EUT may stop as long as it is either automatically reset or can be manually restored by operation of the controls.



1.6 Test Equipment List and Details

Description	Manufacturer	Model	Serial No.	Cal. Date	Due. Date
<input type="checkbox"/> Chamber A: Below 1GHz					
Spectrum Analyzer	Rohde & Schwarz	FSP30	836079/035	2023-02-25	2024-02-24
EMI Test Receiver	Rohde & Schwarz	ESVB	825471/005	2023-02-25	2024-02-24
Trilog Broadband Antenna	Schwarz beck	VULB9163	9163-333	2023-03-20	2026-03-19
Loop Antenna	Schwarz beck	FMZB 1516	9773	2021-03-20	2024-03-19
Amplifier	HP	8447F	2805A03475	2023-02-25	2024-02-24
<input type="checkbox"/> Chamber A: Above 1GHz					
Amplifier	C&D	PAP-1G18	2002	2023-02-25	2024-02-24
Horn Antenna	ETS	3117	00086197	2021-03-19	2024-03-18
<input checked="" type="checkbox"/> Chamber B: Below 1GHz					
Trilog Broadband Antenna	Schwarz beck	VULB9163(B)	9163-635	2021-04-09	2024-04-08
Amplifier	Agilent	8447D	2944A10179	2023-02-25	2024-02-24
EMI Test Receiver	Rohde & Schwarz	ESPI	101391	2023-02-25	2024-02-24
<input type="checkbox"/> Chamber C: Below 1GHz					
EMI Test Receiver	Rohde & Schwarz	ESIB 26	100401	2023-02-25	2024-02-24
Trilog Broadband Antenna	Schwarz beck	VULB 9168	1194	2021-05-28	2024-05-27
Amplifier	HP	8447F	2944A03869	2023-02-25	2024-02-24
<input type="checkbox"/> Chamber C: Above 1GHz					
Horn Antenna	POAM	RTF-11A	LP228060221	2023-03-10	2026-03-09
Amplifier	Tonscend	TAP01018050	AP22E806235	2023-02-25	2024-02-24
<input checked="" type="checkbox"/> Conducted Room 1#					
EMI Test Receiver	Rohde & Schwarz	ESPI	101611	2023-02-25	2024-02-24
Pulse Limiter	Rohde & Schwarz	ESH3-Z2	100911	2023-02-25	2024-02-24
AC LISN	Schwarz beck	NSLK8126	8126-224	2023-02-25	2024-02-24
8-WIRE LISN	Schwarz beck	8158	CAT3-8158-00 59	2023-02-25	2024-02-24
8-WIRE LISN	Schwarz beck	8158	CAT5-8158-011 7	2023-02-25	2024-02-24
<input type="checkbox"/> Conducted Room 2#					
EMI Test Receiver	Rohde & Schwarz	ESPI	10129	2023-02-25	2024-02-24
LISN	Rohde & Schwarz	ENV 216	100097	2023-02-25	2024-02-24
<input checked="" type="checkbox"/> Harmonics & Flicker					
Digital Power Analyzer	California Instrument	CTS	72831	2023-02-25	2024-02-24
Power Source	California Instrument	5001IX-CTS-400	25965	2023-02-25	2024-02-24



<input checked="" type="checkbox"/> Electrostatic discharges					
ESD Generator	LIONCEL	ESD-203B	0170901	2023-03-14	2024-03-13
<input checked="" type="checkbox"/> Power-frequency magnetic field (PFMF)					
PMF Generator	LIONCEL	PMF-801C-C	0171101	2023-02-25	2024-02-24
PMF Antenna	LIONCEL	PMF-801C-A	0180302	2023-02-25	2024-02-24
Instantaneous PMF Generator Module	LIONCEL	PMF-801C-T	0171001	2023-02-25	2024-02-24
<input checked="" type="checkbox"/> Electronic fast transient(EFT)/Surges/Dips					
Transient 2000	EMC PARTNER	TRA2000	863	2023-02-25	2024-02-24
Couple Clamp	EMC PARTNER	CN-EFT1000	513	2023-02-25	2024-02-24
<input checked="" type="checkbox"/> Radio frequency, continuous conducted (C/S)					
CONDUCTED IMMUNITY TEST SYSTEM	FRANKONIA	CIT-10/75	126B1247/201 3	2023-02-25	2024-02-24
Attenuator	EMTEST	MA-5100/6BF2	1009	2023-02-25	2024-02-24
CDN	Luthi	L-801M2/M3	2665	2023-02-25	2024-02-24
CDN	LIONCEL	CDN-T8	0210401	2023-02-25	2024-02-24
EM Clamp	TESEQ	KEMZ801A	45028	2023-02-25	2024-02-24
<input checked="" type="checkbox"/> Radio frequency electromagnetic Field (R/S)					
Signal Generator	HP	8688B	3438A00604	2023-02-25	2024-02-24
Power Sensor	Agilent	E9301A	MY52450001	2023-02-25	2024-02-24
Power Sensor	Agilent	E9304A	MY55081055	2023-02-25	2024-02-24
RF Power Amplifier	MicoTop	MPA-80-1000-250	MPA1906239	2023-02-25	2024-02-24
RF Power Amplifier	MicoTop	MPA-1000-6000-10 0	MPA1906238	2023-02-25	2024-02-24
Antenna	SCHWARZBECK	STLP 9129	9129 114	N/A	N/A
Power Meter	Agilent	E4419B	GB42420578	2023-02-25	2024-02-24



2. SUMMARY OF TEST RESULTS

Standards	Description of Test Item	Result
EN 55032	Conducted Emission	Compliant
	Radiated Emission	Compliant
EN IEC 61000-3-2	Harmonic Current Emission	Compliant
EN 61000-3-3	Voltage Fluctuation and Flicker	Compliant
EN 55035	Electrostatic Discharge Immunity in accordance with EN 61000-4-2	Compliant
	Continuous RF electromagnetic field Disturbances Immunity in accordance with EN 61000-4-3	Compliant
	Electrical Fast Transient/Burst Immunity in accordance with EN 61000-4-4	Compliant
	Surges Immunity in accordance with EN 61000-4-5	Compliant
	Continuous induced RF disturbances Immunity in accordance with EN 61000-4-6	Compliant
	Power-frequency Magnetic Fields Immunity in accordance With EN 61000-4-8	Compliant
	Voltage Dips/Interruptions Immunity in accordance with EN 61000-4-11	Compliant
	Broadband impulse noise disturbances, repetitive	N/A
Broadband impulse noise disturbances, isolated	N/A	

N/A: not applicable

3. Conducted Emission

3.1 Measurement Uncertainty

Base on NIS 81, The Treatment of Uncertainty in EMC Measurements, the best estimate of the uncertainty of any conducted emissions measurement:

Measurement uncertainty		
Parameter	Conditions	Uncertainty
Conducted Emissions	Conducted	9-150kHz ± 3.74 dB
		0.15-30MHz ± 3.34 dB

3.2 Basic Test Setup Block Diagram

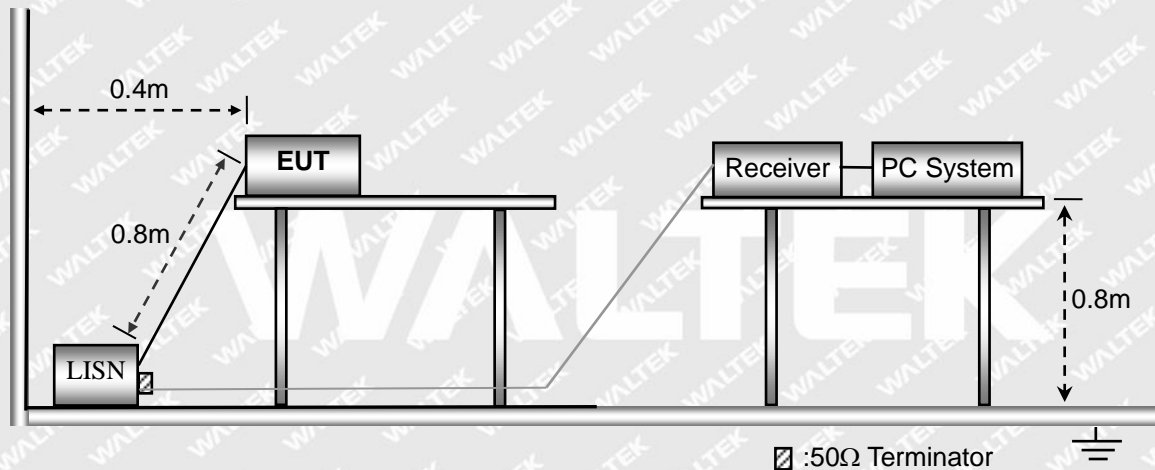

3.3 Environmental Conditions

Temperature:	23.5 °C
Relative Humidity:	54 %
ATM Pressure:	997 mbar

3.4 Summary of Test Results

Please find the results below:



Test mode:	TM1	Polarity:	Line
------------	-----	-----------	------

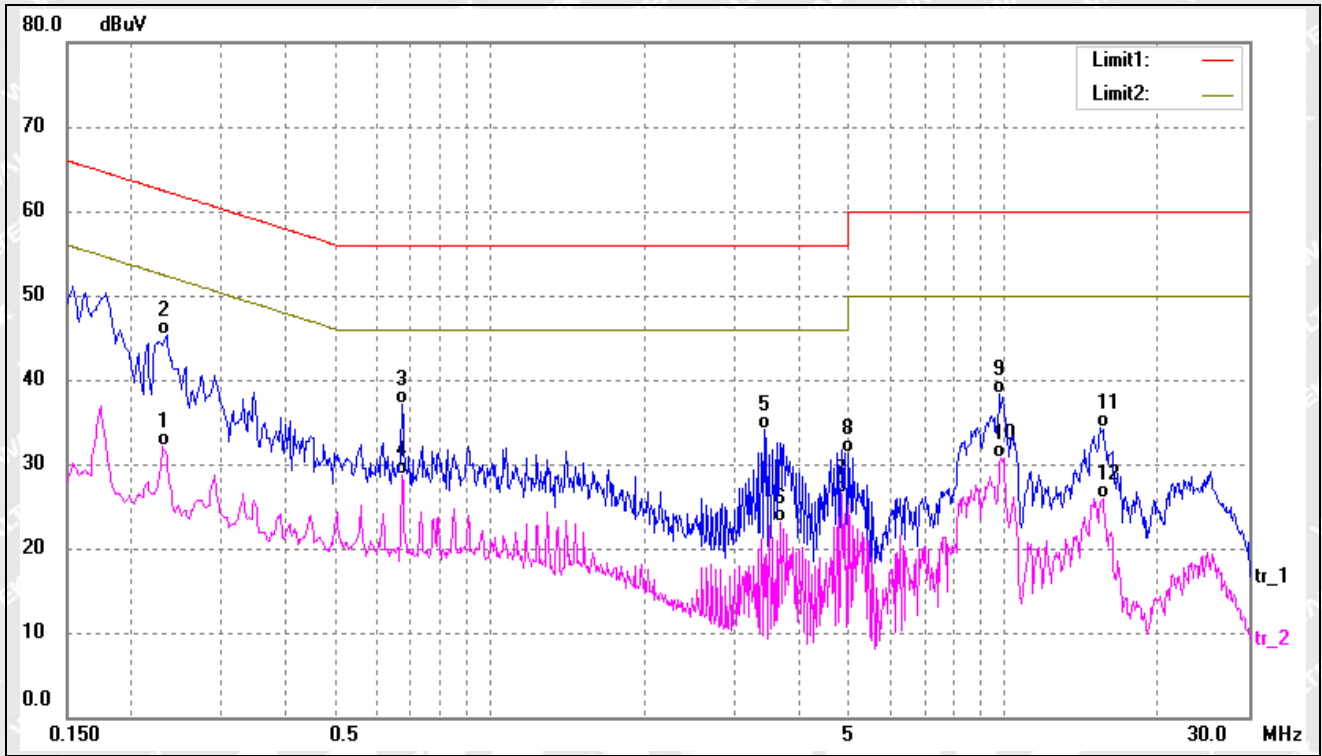

No.	Frequency (MHz)	Reading (dBuV)	Correct (dB)	Result (dBuV)	Limit (dBuV)	Margin (dB)	Detector
1	0.2300	21.69	10.36	32.05	52.45	-20.40	AVG
2*	0.2340	34.89	10.35	45.24	62.30	-17.06	QP
3	0.6740	26.92	10.20	37.12	56.00	-18.88	QP
4	0.6740	18.53	10.20	28.73	46.00	-17.27	AVG
5	3.4340	23.74	10.35	34.09	56.00	-21.91	QP
6	3.6660	12.66	10.36	23.02	46.00	-22.98	AVG
7	4.8460	16.17	10.38	26.55	46.00	-19.45	AVG
8	4.9620	20.92	10.38	31.30	56.00	-24.70	QP
9	9.8580	28.00	10.38	38.38	60.00	-21.62	QP
10	9.8620	20.34	10.38	30.72	50.00	-19.28	AVG
11	15.4380	24.09	10.24	34.33	60.00	-25.67	QP
12	15.5540	15.73	10.24	25.97	50.00	-24.03	AVG



Test mode:	TM1	Polarity:	Neutral
------------	-----	-----------	---------

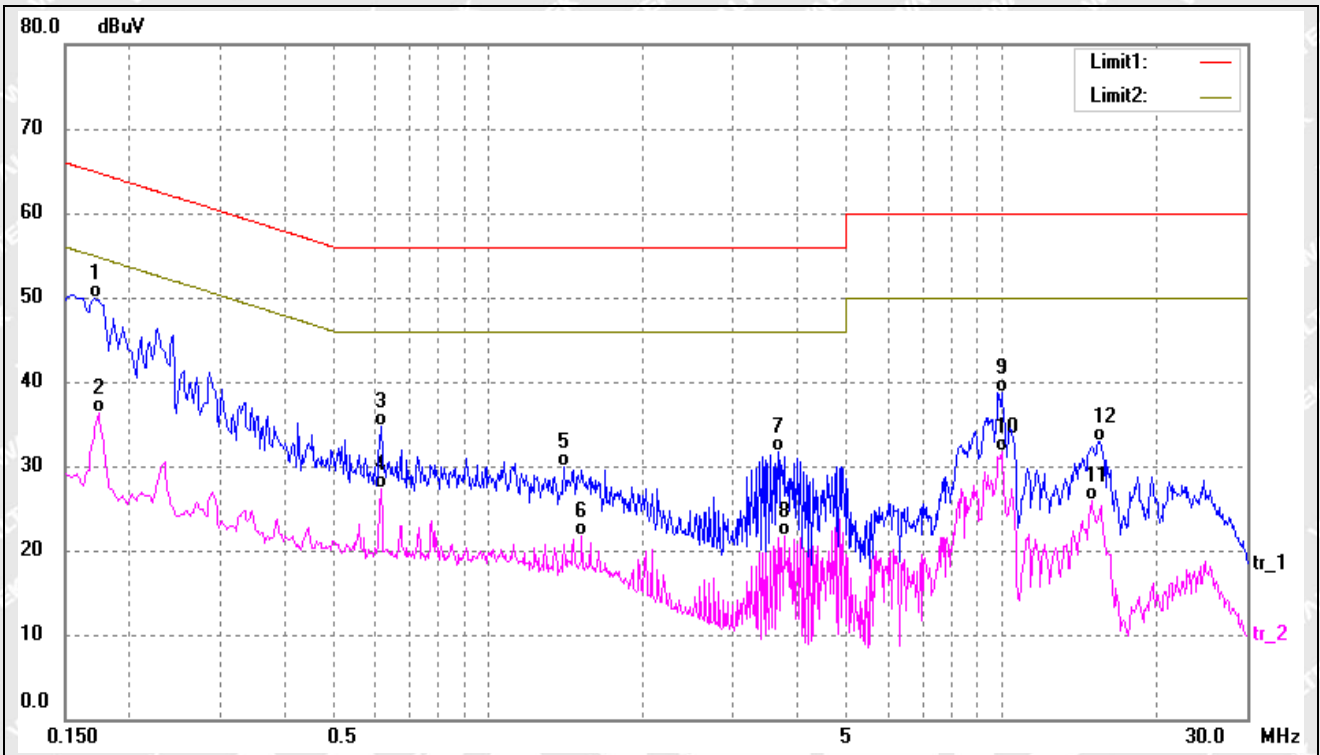

No.	Frequency (MHz)	Reading (dBuV)	Correct (dB)	Result (dBuV)	Limit (dBuV)	Margin (dB)	Detector
1*	0.1700	39.60	10.40	50.00	64.96	-14.96	QP
2	0.1740	25.84	10.39	36.23	54.76	-18.53	AVG
3	0.6180	24.52	10.21	34.73	56.00	-21.27	QP
4	0.6180	17.01	10.21	27.22	46.00	-18.78	AVG
5	1.4100	19.75	10.22	29.97	56.00	-26.03	QP
6	1.5220	11.52	10.24	21.76	46.00	-24.24	AVG
7	3.6620	21.43	10.36	31.79	56.00	-24.21	QP
8	3.7780	11.27	10.36	21.63	46.00	-24.37	AVG
9	9.9660	28.42	10.38	38.80	60.00	-21.20	QP
10	9.9660	21.39	10.38	31.77	50.00	-18.23	AVG
11	14.9820	15.67	10.22	25.89	50.00	-24.11	AVG
12	15.5420	22.62	10.24	32.86	60.00	-27.14	QP



Test mode:	TM2	Polarity:	Line
------------	-----	-----------	------

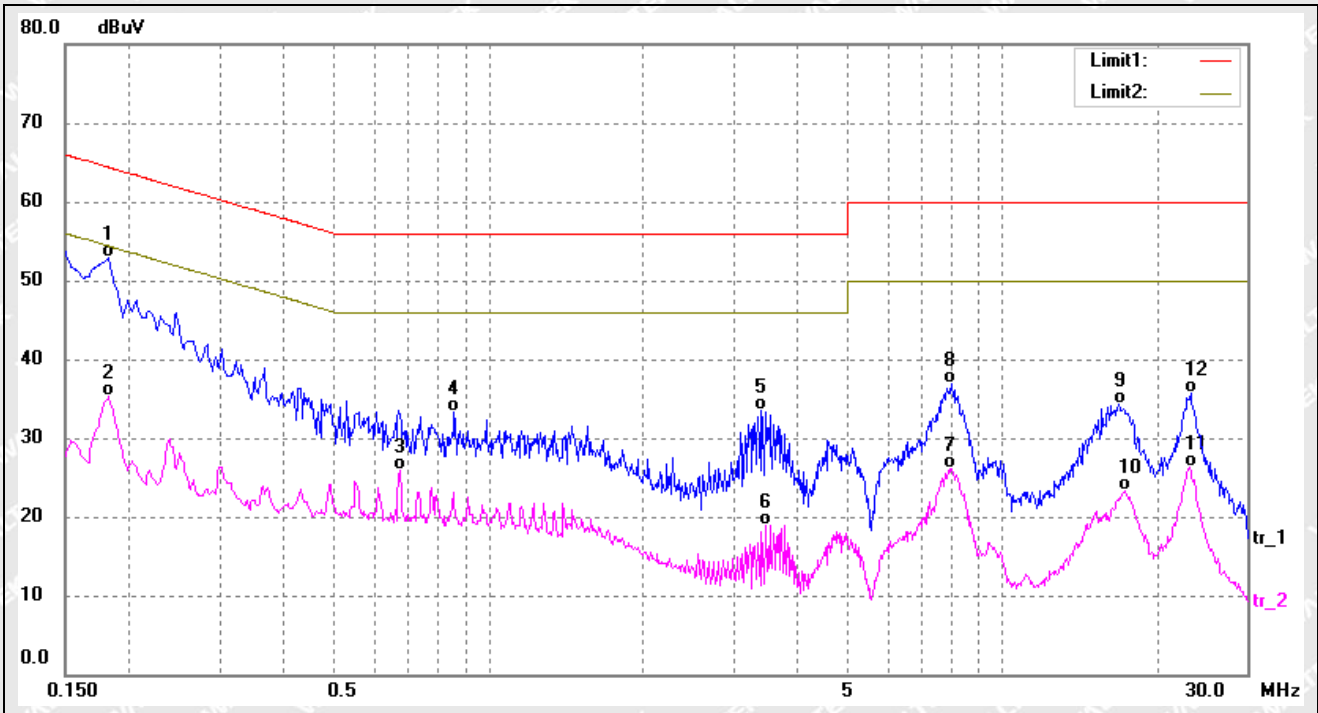

No.	Frequency (MHz)	Reading (dBuV)	Correct (dB)	Result (dBuV)	Limit (dBuV)	Margin (dB)	Detector
1*	0.1819	42.58	10.39	52.97	64.39	-11.42	QP
2	0.1819	24.83	10.39	35.22	54.39	-19.17	AVG
3	0.6740	15.65	10.20	25.85	46.00	-20.15	AVG
4	0.8580	23.20	10.17	33.37	56.00	-22.63	QP
5	3.4140	23.08	10.35	33.43	56.00	-22.57	QP
6	3.4780	8.65	10.35	19.00	46.00	-27.00	AVG
7	7.9100	15.77	10.38	26.15	50.00	-23.85	AVG
8	7.9780	26.45	10.38	36.83	60.00	-23.17	QP
9	16.9180	24.10	10.28	34.38	60.00	-25.62	QP
10	17.3620	13.02	10.30	23.32	50.00	-26.68	AVG
11	23.1980	15.93	10.32	26.25	50.00	-23.75	AVG
12	23.2660	25.31	10.32	35.63	60.00	-24.37	QP



Test mode:	TM2	Polarity:	Neutral
------------	-----	-----------	---------

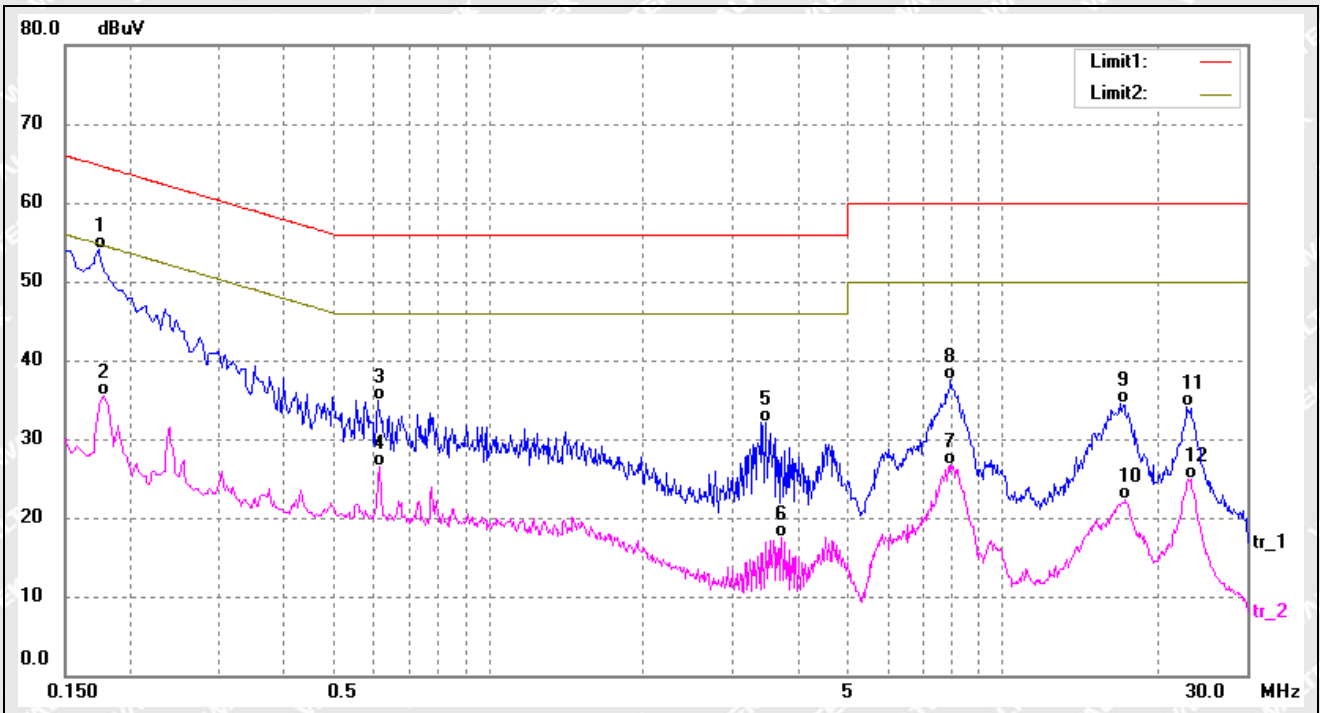

No.	Frequency (MHz)	Reading (dBuV)	Correct (dB)	Result (dBuV)	Limit (dBuV)	Margin (dB)	Detector
1*	0.1740	43.77	10.39	54.16	64.76	-10.60	QP
2	0.1780	25.16	10.39	35.55	54.57	-19.02	AVG
3	0.6100	24.72	10.22	34.94	56.00	-21.06	QP
4	0.6140	16.23	10.22	26.45	46.00	-19.55	AVG
5	3.4700	21.78	10.35	32.13	56.00	-23.87	QP
6	3.7260	7.06	10.36	17.42	46.00	-28.58	AVG
7	7.9180	16.36	10.38	26.74	50.00	-23.26	AVG
8	7.9700	27.11	10.38	37.49	60.00	-22.51	QP
9	16.9820	24.28	10.28	34.56	60.00	-25.44	QP
10	17.3900	11.94	10.30	22.24	50.00	-27.76	AVG
11	22.9540	23.87	10.33	34.20	60.00	-25.80	QP
12	23.2860	14.63	10.32	24.95	50.00	-25.05	AVG



4. Radiated Emission

4.1 Measurement Uncertainty

Base on NIS 81, The Treatment of Uncertainty in EMC Measurements, the best estimate of the uncertainty of any radiation emissions measurement:

Measurement uncertainty		
Parameter	Conditions	Uncertainty
Radiated Emissions	Radiated	30-200MHz $\pm 4.52\text{dB}$
		0.2-1GHz $\pm 5.56\text{dB}$
		1-6GHz $\pm 3.84\text{dB}$
		6-18GHz $\pm 3.92\text{dB}$

4.2 Basic Test Setup Block Diagram

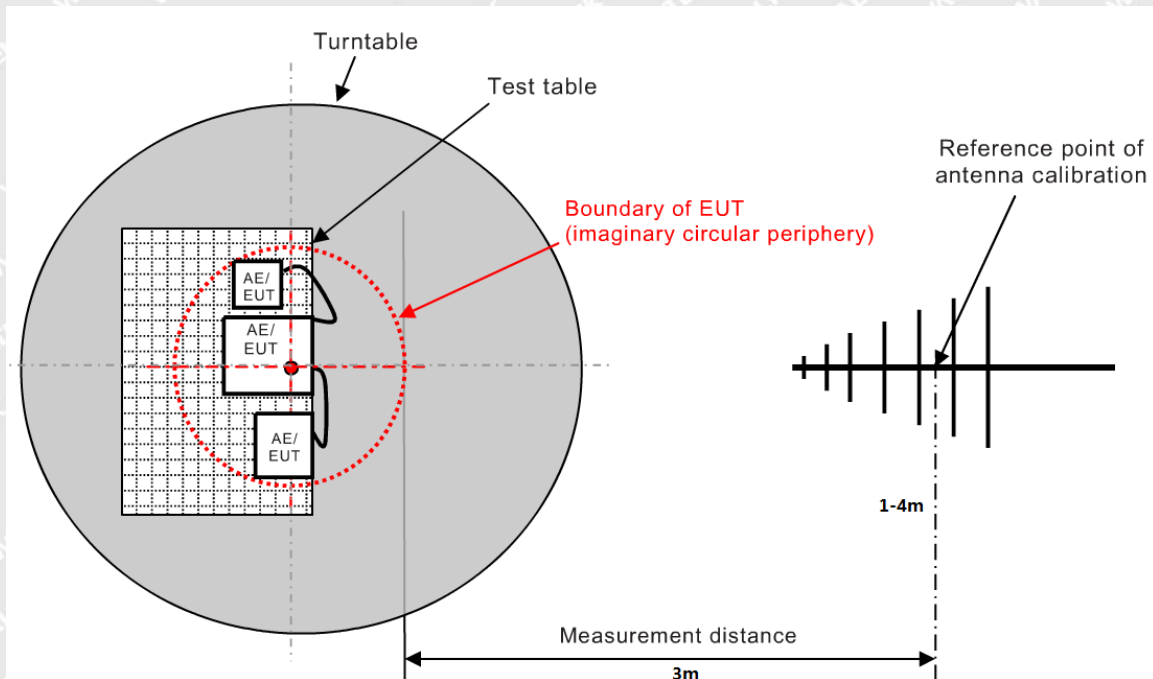



4.3 Corrected Amplitude & Margin Calculation

The Corrected Amplitude is calculated by adding the Antenna Factor and the Cable Factor, and subtracting the Amplifier Gain from the Amplitude reading. The basic equation is as follows:

$$\text{Corr. Ampl.} = \text{Indicated Reading} + \text{Correct} \\ \text{Correct} = \text{Ant. Factor} + \text{Cable Loss} - \text{Ampl. Gain}$$

The “**Margin**” column of the following data tables indicates the degree of compliance with the applicable limit. For example, a margin of -6dB μ V means the emission is 6dB μ V below the maximum limit for Class B device. The equation for margin calculation is as follows:

$$\text{Margin} = \text{Corr. Ampl.} - \text{EN 55032 Class B Limit}$$

4.4 Environmental Conditions

Temperature:	23.5 °C
Relative Humidity:	54 %
ATM Pressure:	997 mbar

4.5 Summary of Test Results

Please find the results below:

WALTEK



Test mode:	TM1	Polarity:	Horizontal
------------	-----	-----------	------------

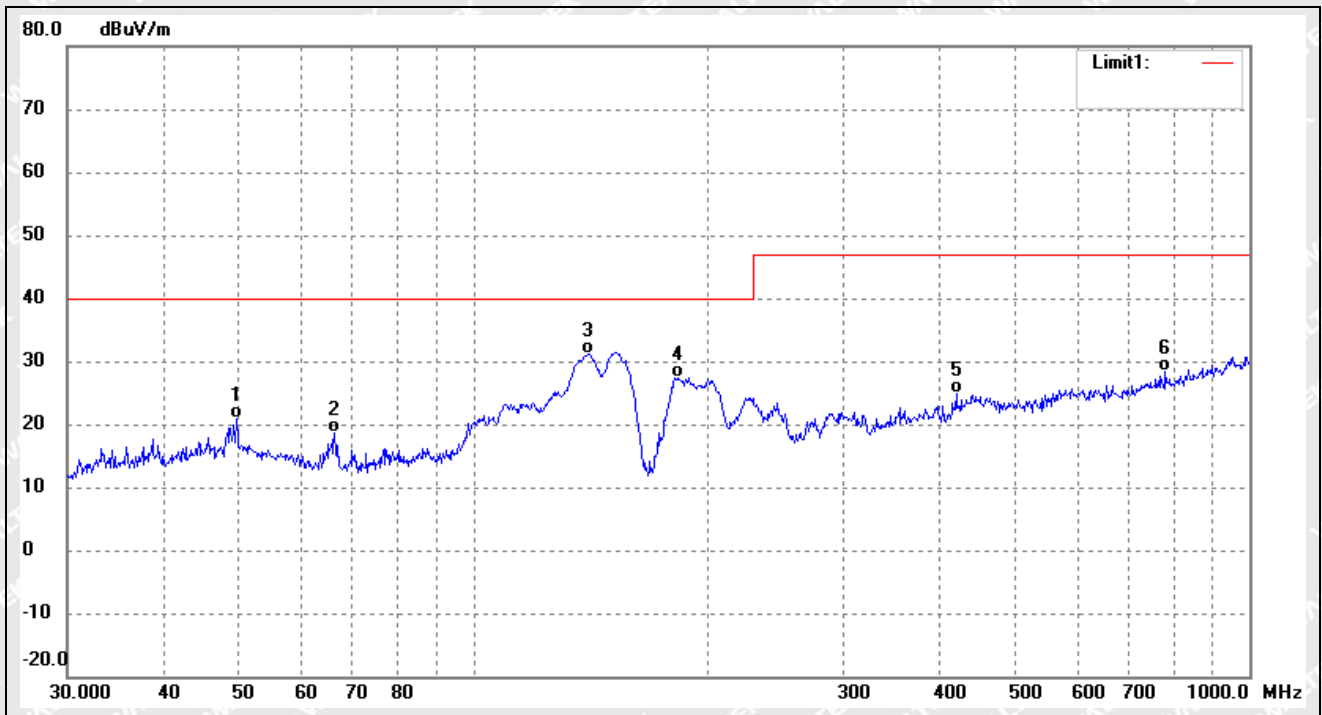

No.	Frequency (MHz)	Reading (dBuV/m)	Correct (dB/m)	Result (dBuV/m)	Limit (dBuV/m)	Margin (dB)	Remark
1	49.5328	31.14	-10.23	20.91	40.00	-19.09	QP
2	66.2661	31.92	-13.29	18.63	40.00	-21.37	QP
3	140.3420	45.69	-14.50	31.19	40.00	-8.81	QP
4	183.8439	40.27	-12.84	27.43	40.00	-12.57	QP
5	419.1080	29.51	-4.60	24.91	47.00	-22.09	QP
6	779.6068	28.98	-0.56	28.42	47.00	-18.58	QP



Test mode:	TM1	Polarity:	Vertical
------------	-----	-----------	----------



No.	Frequency (MHz)	Reading (dBuV/m)	Correct (dB/m)	Result (dBuV/m)	Limit (dBuV/m)	Margin (dB)	Remark
1	41.5670	37.06	-11.39	25.67	40.00	-14.33	QP
2	110.1816	43.64	-12.17	31.47	40.00	-8.53	QP
3	141.3298	49.92	-14.53	35.39	40.00	-4.61	QP
4	202.1005	38.18	-11.25	26.93	40.00	-13.07	QP
5	435.5898	29.47	-4.40	25.07	47.00	-21.93	QP
6	609.9217	28.74	-2.33	26.41	47.00	-20.59	QP



Test mode:	TM2	Polarity:	Horizontal
------------	-----	-----------	------------

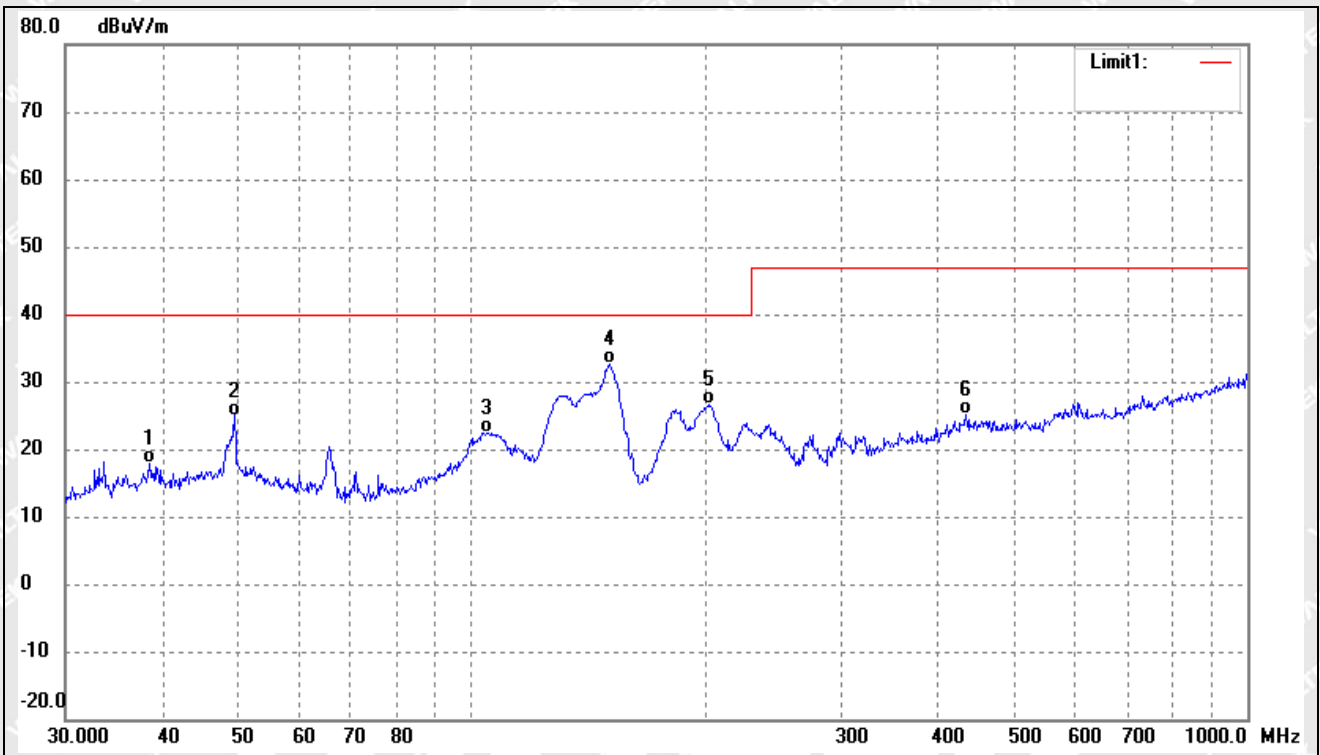

No.	Frequency (MHz)	Reading (dBuV/m)	Correct (dB/m)	Result (dBuV/m)	Limit (dBuV/m)	Margin (dB)	Remark
1	38.4809	29.84	-12.01	17.83	40.00	-22.17	QP
2	49.5328	35.23	-10.23	25.00	40.00	-15.00	QP
3	104.5361	34.65	-12.27	22.38	40.00	-17.62	QP
4	151.0666	47.34	-14.79	32.55	40.00	-7.45	QP
5	202.1005	37.77	-11.25	26.52	40.00	-13.48	QP
6	434.0651	29.64	-4.40	25.24	47.00	-21.76	QP



Test mode:	TM2	Polarity:	Vertical
------------	-----	-----------	----------



No.	Frequency (MHz)	Reading (dBuV/m)	Correct (dB/m)	Result (dBuV/m)	Limit (dBuV/m)	Margin (dB)	Remark
1	45.3755	39.79	-10.54	29.25	40.00	-10.75	QP
2	109.4116	39.87	-12.17	27.70	40.00	-12.30	QP
3	150.5378	50.76	-14.81	35.95	40.00	-4.05	QP
4	198.5879	38.19	-11.41	26.78	40.00	-13.22	QP
5	317.7010	29.51	-7.35	22.16	47.00	-24.84	QP
6	549.0193	28.60	-3.82	24.78	47.00	-22.22	QP



5. Harmonic Current Emissions

5.1 Test Procedure

Test is conducted under the description of EN IEC 61000-3-2.

5.2 Test Standards

EN IEC 61000-3-2, Clause 7.2 Limits for Class A equipment.

5.3 Environmental Conditions

Temperature:	23.5 °C
Relative Humidity:	52 %
ATM Pressure:	997 mbar

5.4 Basic Test Setup Block Diagram

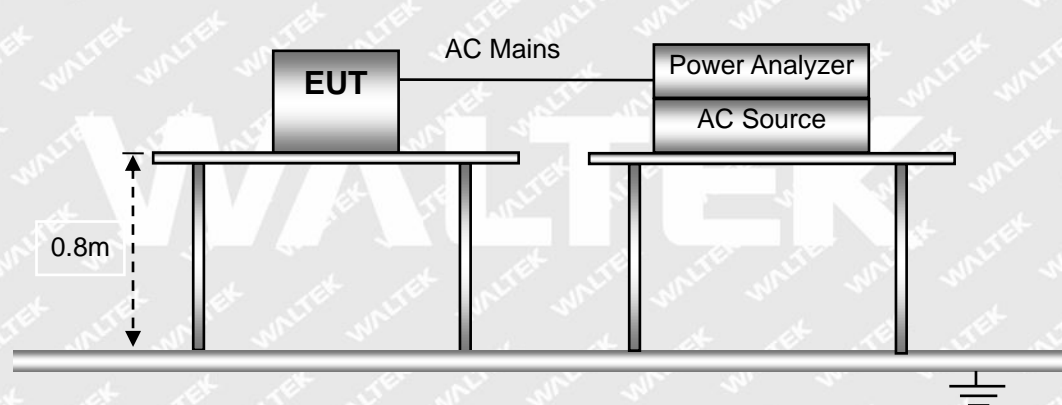

5.5 Harmonic Current Emissions Test Data

According to Clause 7 of EN IEC 61000-3-2, the rated power of the EUT is less than 75W, belong to 'equipment with a rated power of 75W or less', therefore 'limits are not specified in this edition of the standards'. It is deem to full fit the requirements of the standards.

Result: The EUT is compliance with the requirements of this section.



6. Voltage Fluctuation Flicker

6.1 Test Procedure

Test is conducted under the description of EN 61000-3-3.

6.2 Test Standards

EN 61000-3-3, Limit: Clause 5.

6.3 Environmental Conditions

Temperature:	23.5 °C
Relative Humidity:	52 %
ATM Pressure:	997 mbar

6.4 Basic Test Setup Block Diagram

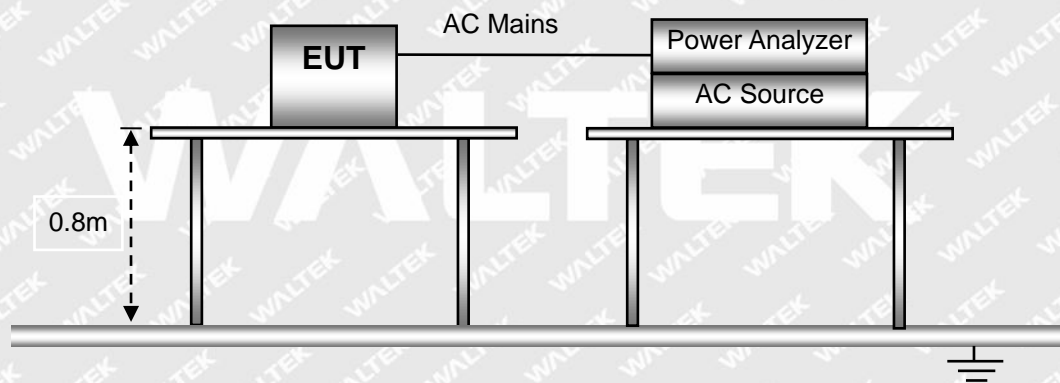

6.5 Voltage Fluctuation and Flicker Test Data



Test mode:	TM1
------------	-----

Flicker Test Summary per IEC61000-3-3:2013+AMD2:2021 (Run time)

Comment: TM1

Customer: Customer information

Test Result: Pass

Status: Test Completed

Pst_i and limit line

European Limits



Plt and limit line



Parameter values recorded during the test:

Vrms at the end of test (Volt): 230.07

Highest dt (%):

Test limit (%):

T-max (mS): 0

Test limit (mS): 500.0 Pass

Highest dc (%): 0.00

Test limit (%): 3.30 Pass

Highest dmax (%): 0.00

Test limit (%): 4.00 Pass

Highest Pst (10 min. period): 0.244

Test limit: 1.000 Pass

Highest Plt (2 hr. period): 0.107

Test limit: 0.650 Pass



7. Electrostatic Discharges (ESD)

7.1 Test Procedure

Test is conducted under the description of EN 61000-4-2.

7.2 Test Performance

Performance Criterion: B

7.3 Environmental Conditions

Temperature:	20.5 °C
Relative Humidity:	47 %
ATM Pressure:	997 mbar

7.4 Basic Test Setup Block Diagram

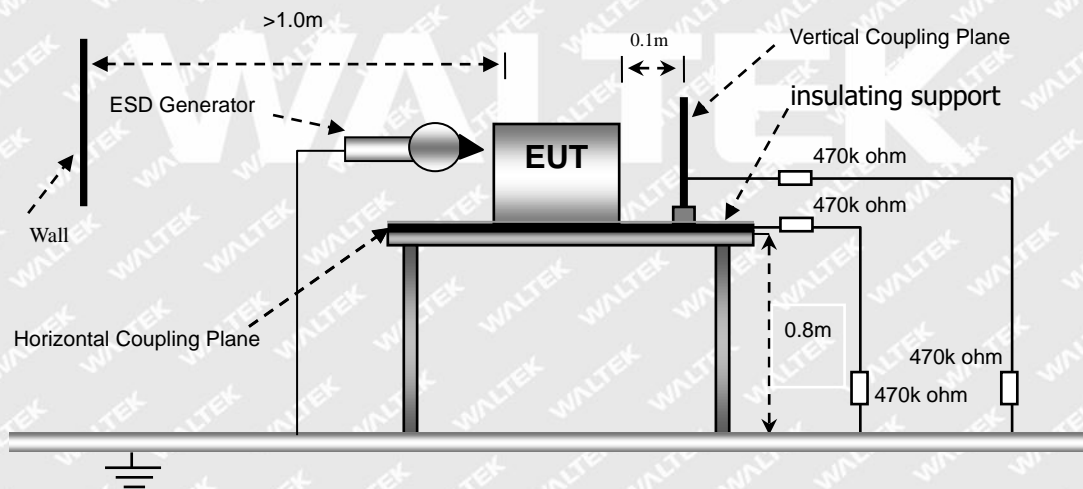



7.5 Electrostatic Discharge Immunity Test Data

Table 1: Electrostatic Discharge Immunity (Air Discharge)

EN 61000-4-2 Test Points	Test Voltage (kV)									
	-2	+2	-4	+4	-6	+6	-8	+8	-10	+10
Edge gap	A	A	A	A	A	A	A	A	/	/
Pilot lamp	A	A	A	A	A	A	A	A	/	/

Table 2: Electrostatic Discharge Immunity (Direct Contact)

EN 61000-4-2 Test Points	Test Voltage (kV)									
	-2	+2	-4	+4	-6	+6	-8	+8	-10	+10
/	/	/	/	/	/	/	/	/	/	/

Table 3: Electrostatic Discharge Immunity (Indirect Contact HCP & VCP)

EN 61000-4-2 Test Points	Test Voltage (kV)									
	-2	+2	-4	+4	-6	+6	-8	+8	-10	+10
HCP (6 Sides)	A	A	A	A	/	/	/	/	/	/
VCP (4 Sides)	A	A	A	A	/	/	/	/	/	/

Test Result: Pass

8. Continuous RF Electromagnetic Field Disturbances (RS)

8.1 Test Procedure

Test is conducted under the description of EN 61000-4-3.

8.2 Test Performance

Performance Criterion: A

8.3 Environmental Conditions

Temperature:	23.0 °C
Relative Humidity:	54 %
ATM Pressure:	997 mbar

8.4 Basic Test Setup Block Diagram

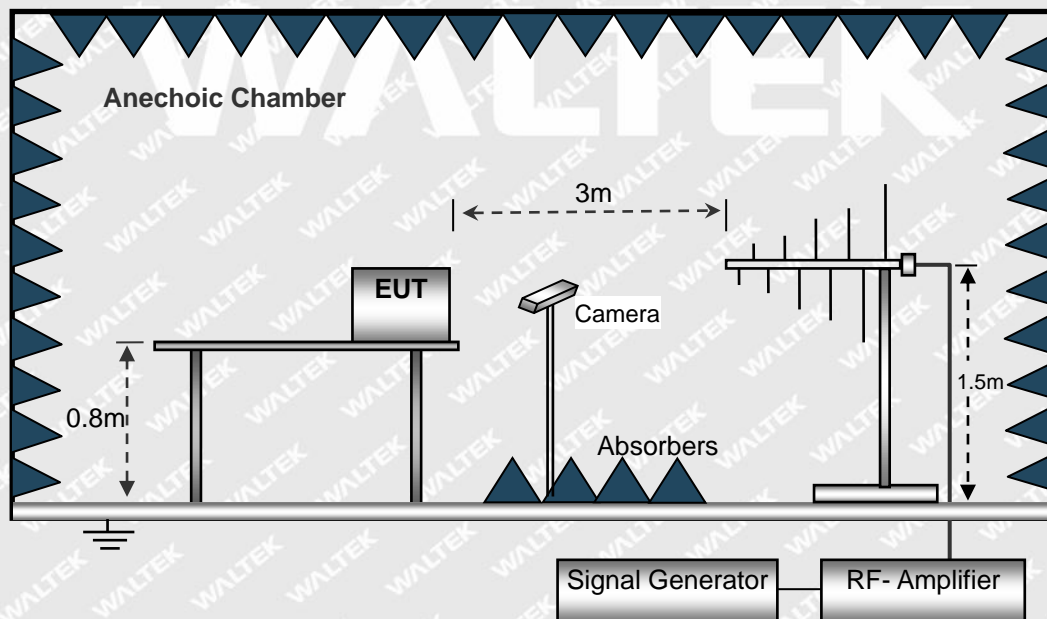



8.5 Continuous Radiated Disturbances Test Data

Frequency step: 1% of fundamental

Dwell time: 1 second

Modulation: AM by 1kHz sine wave with 80% modulation depth

Frequency Range(MHz)	Field (V/m)	Front		Rear		Left Side		Right Side	
		VERT	HORI	VERT	HORI	VERT	HORI	VERT	HORI
80-1000	3	A	A	A	A	A	A	A	A

Spot frequencies (MHz)	Field (V/m)	Front		Rear		Left Side		Right Side	
		VERT	HORI	VERT	HORI	VERT	HORI	VERT	HORI
1800	3	A	A	A	A	A	A	A	A
2600	3	A	A	A	A	A	A	A	A
3500	3	A	A	A	A	A	A	A	A
5000	3	A	A	A	A	A	A	A	A

Test Result: Pass



9. Electrical Fast Transients (EFT)

9.1 Test Procedure

Test is conducted under the description of EN 61000-4-4.

9.2 Test Performance

Performance Criterion: B

9.3 Environmental Conditions

Temperature:	23.5 °C
Relative Humidity:	51 %
ATM Pressure:	997 mbar

9.4 Basic Test Setup Block Diagram

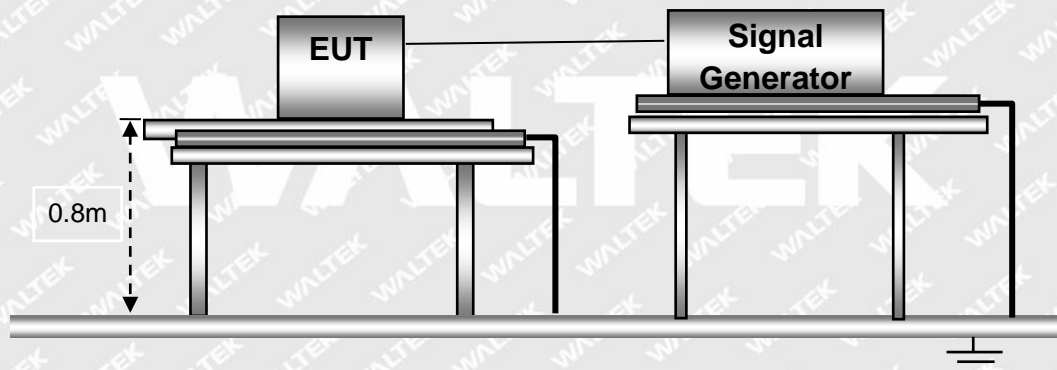



9.5 Electrical Fast Transients Test Data

EN 61000-4-4 Test Points		Test Voltage (kV)							
		+0.5	-0.5	+1.0	-1.0	+2.0	-2.0	+4.0	-4.0
Power Supply Power Port of EUT	L	/	/	A	A	/	/	/	/
	N	/	/	A	A	/	/	/	/
	PE	/	/	/	/	/	/	/	/
	L+N	/	/	A	A	/	/	/	/
	L+PE	/	/	/	/	/	/	/	/
	N+PE	/	/	/	/	/	/	/	/
	L+N+PE	/	/	/	/	/	/	/	/
Signal ports	RJ45	/	/	/	/	/	/	/	/

Test Result: Pass

WALTEK



10. Surges

10.1 Test Procedure

Test is conducted under the description of EN 61000-4-5.

10.2 Test Performance

Performance Criterion: B

10.3 Environmental Conditions

Temperature:	24 °C
Relative Humidity:	51 %
ATM Pressure:	997 mbar

10.4 Basic Test Setup Block Diagram

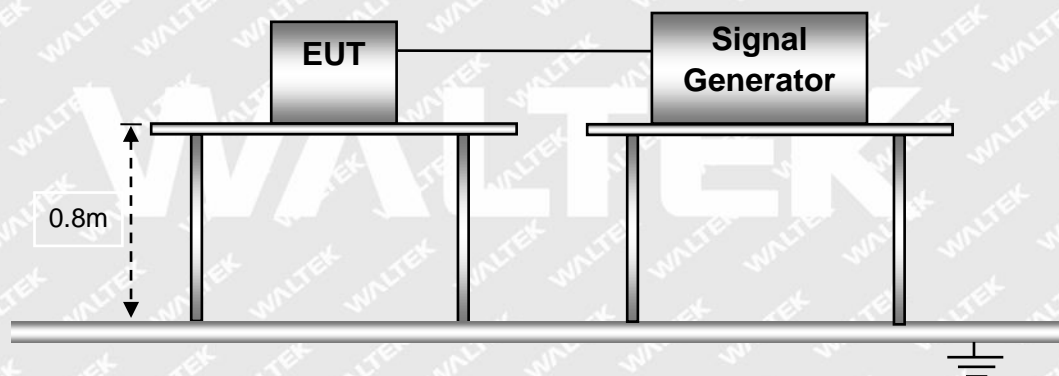



10.5 Surge Test Data

AC Port

Test Voltage (kV)	Poll	Path	Pass	Fail
0.5kV	±	L-N	/	/
1kV	±	L-N	A	/
2kV	±	L-N, L-PE, N-PE	/	/
4kV	±	L-PE, N-PE	/	/

Test Result: Pass

WALTEK



11. Continuous Induced RF Disturbances (C/S)

11.1 Test Procedure

Test is conducted under the description of EN 61000-4-6.

11.2 Test Performance

Performance Criterion: A

11.3 Environmental Conditions

Temperature:	23.5 °C
Relative Humidity:	53 %
ATM Pressure:	997 mbar

11.4 Basic Test Setup Block Diagram

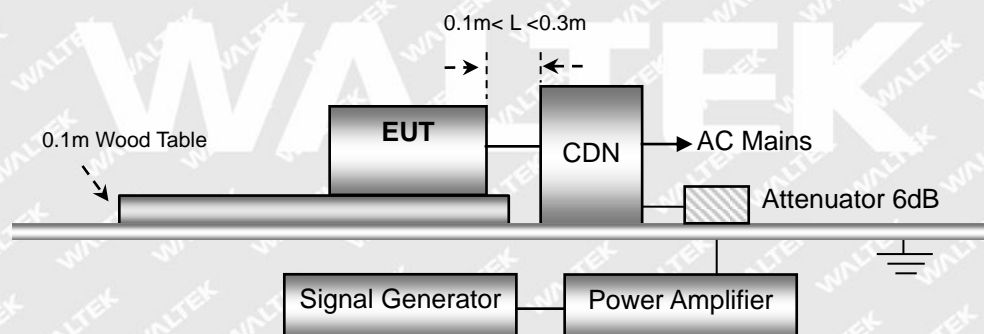



11.5 Continuous Conducted Disturbances Test Data

Sweep frequency range: 0.15MHz to 10MHz 3V; 10MHz to 30MHz 3V to 1V; 30MHz to 80MHz 1V

Frequency step: 1% of fundamental

Dwell time: 1 second

AC Port

Frequency MHz	Injected Position	Voltage level (e.m.f.)	Observations (Performance Criterion)	Result
0.15-10	AC Mains	3V	A	Pass
10-30	AC Mains	3-1V	A	Pass
30-80	AC Mains	1V	A	Pass

Test Result: Pass

WALTEK

12. Power-Frequency Magnetic Fields (PFMF)

12.1 Test Procedure

Test is conducted under the description of EN 61000-4-8.

12.2 Test Performance

Performance Criterion: A

12.3 Environmental Conditions

Temperature:	23.0 °C
Relative Humidity:	52 %
ATM Pressure:	997 mbar

12.4 Basic Test Setup Block Diagram

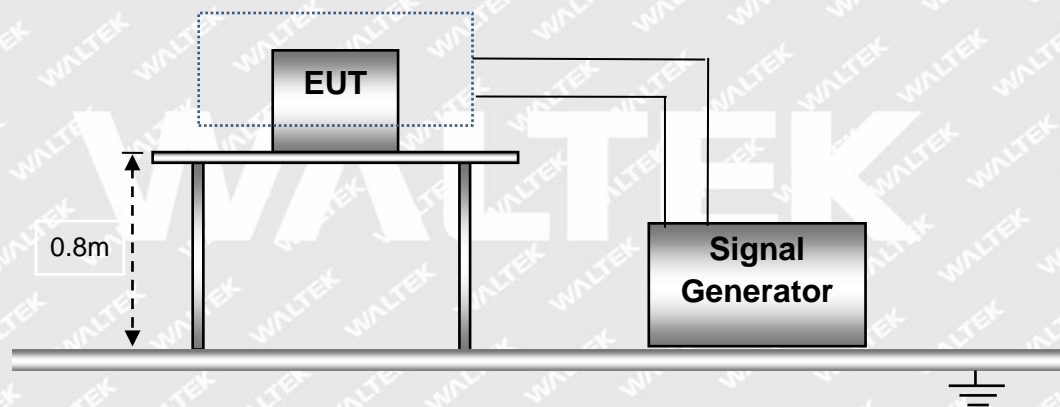

12.5 Power-Frequency Magnetic Field Test Data

Level	Magnetic Field Strength (r.m.s) A/m	Frequency Hz	Induction Coil Position	Pass	Fail
1	1	50/60	X, Y, Z	A	/
2	3	50/60	X, Y, Z	/	/
3	10	50/60	X, Y, Z	/	/
X	Special	/	/	/	/

Test Result: Pass

13. Voltage Dips and Interruptions

13.1 Test Procedure

Test is conducted under the description of EN 61000-4-11.

13.2 Test Performance

Performance Criterion: B/C

13.3 Environmental Conditions

Temperature:	22.5 °C
Relative Humidity:	51 %
ATM Pressure:	997 mbar

13.4 Basic Test Setup Block Diagram

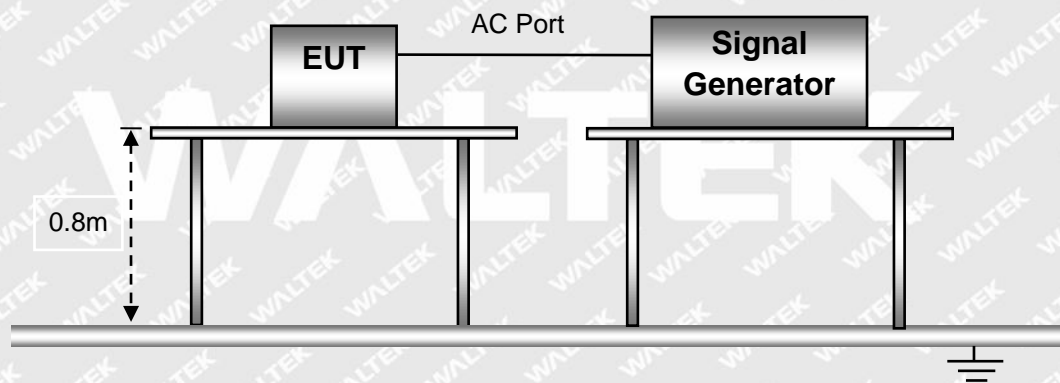

13.5 Voltage Dips And Interruptions Test Data

U: Voltage dips in % U_T (U_T is rated voltage for the EUT)

T: Test duration

Level	U	T	Phase Angle	N	Pass	Fail
1	100%	10ms	0/90/180/270	3	A	/
2	30%	500ms	0/90/180/270	3	B	/
3	100%	5000ms	0/90/180/270	3	C	/

Test Result: Pass



EXHIBIT 1 - PRODUCT LABELING

Proposed CE Label Format

<p>X-plore 8000 Standard Charger Model: R59780 Brand: Dräger or GlobTek, Inc. Importer Name: XXX Importer Address: XXX 1: GlobTek, Inc. 2: GlobTek (Suzhou) Co., Ltd 1: 186 Veterans Dr. Northvale, NJ 07647 USA 2: Building 4, No. 76, Jin Ling East Rd., Suzhou Industrial Park, Suzhou, JiangSu 215021, China</p>	
---	--

Specifications: Text is Black in color and is justified. Labels are printed in indelible ink on permanent adhesive backing or silk-screened onto the EUT or shall be affixed at a conspicuous location on the EUT. The 'CE' marking must be affixed to the EUT or to its data plate. Where this is not possible or not warranted on account of the nature of the apparatus, it must be affixed to the packaging, if any, and to the accompanying documents. The 'CE' marking must have a height of at least 5 mm. If the 'CE' marking is reduced or enlarged the proportions given in the above graduated drawing must be respected. The Importer name, address and Manufacturer name and address should indicate on marking label or packaging or in a document accompanying.

Proposed Label Location on EUT

Label Location





EXHIBIT 2 - EUT PHOTOGRAPHS

EUT View 1



EUT View 2





EUT View 3



EUT View 4





EUT View 5



EUT View 6





Reference No.: WTX23X08183427E001

EUT View 7



EUT View 8





EUT View 9



WALTEK



EUT Housing and Board View 1

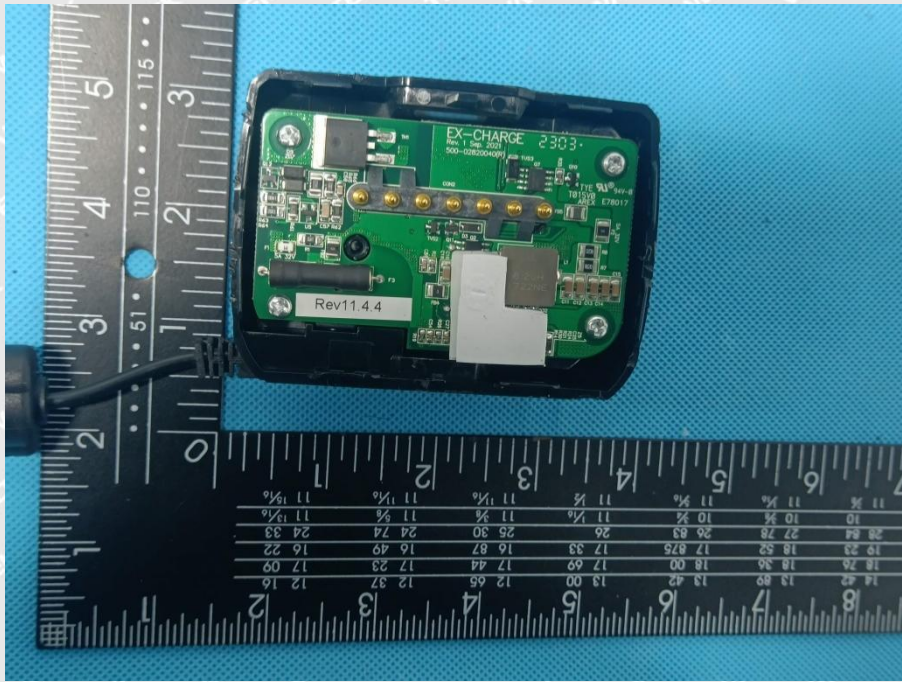

Solder Board-Component View 2

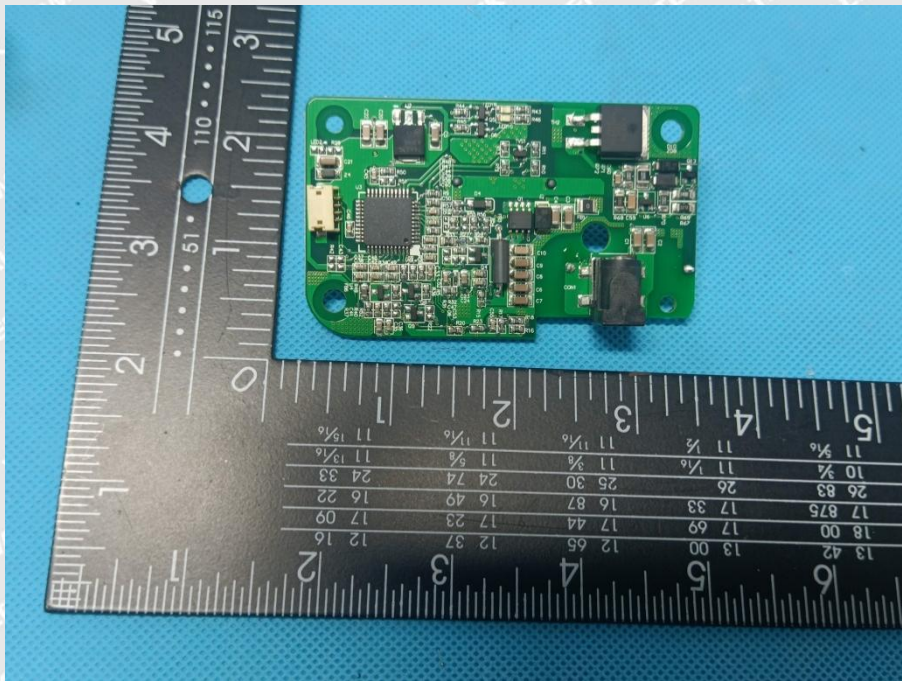



Reference No.: WTX23X08183427E001

Solder Board-Component View 3

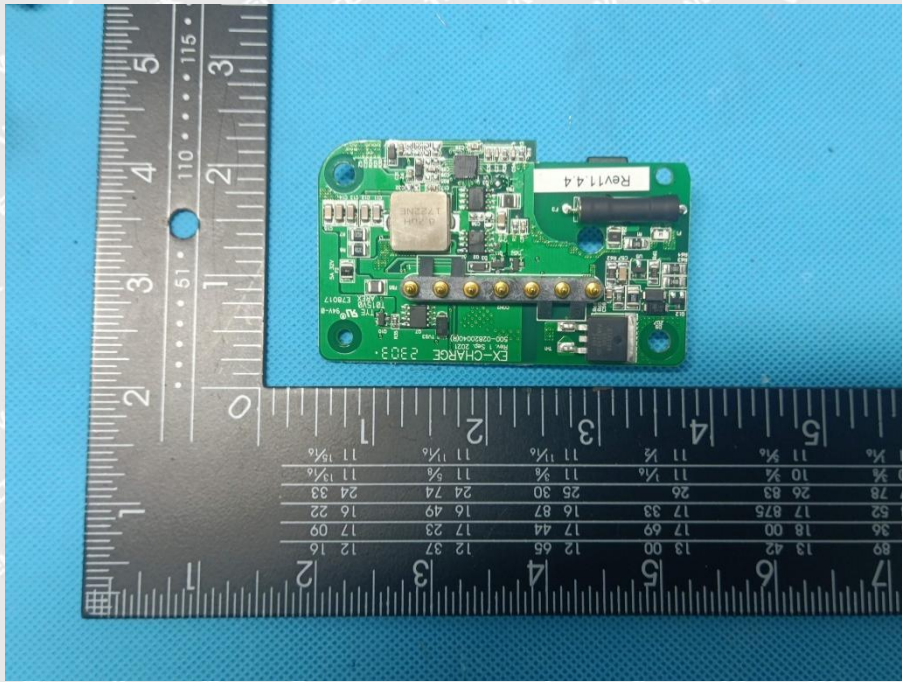

Solder Board-Component View 4

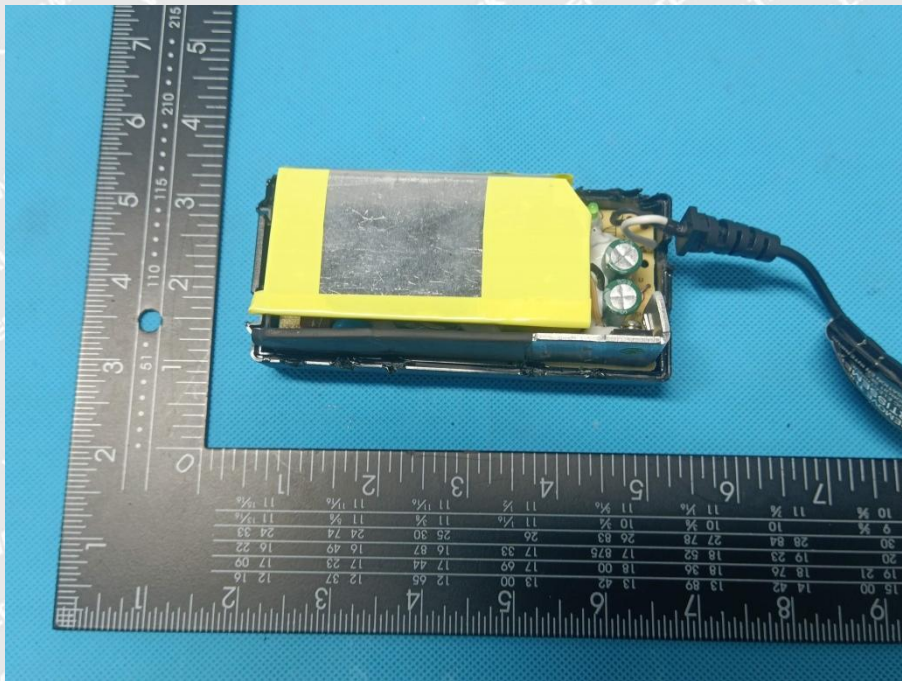



Solder Board-Component View 5

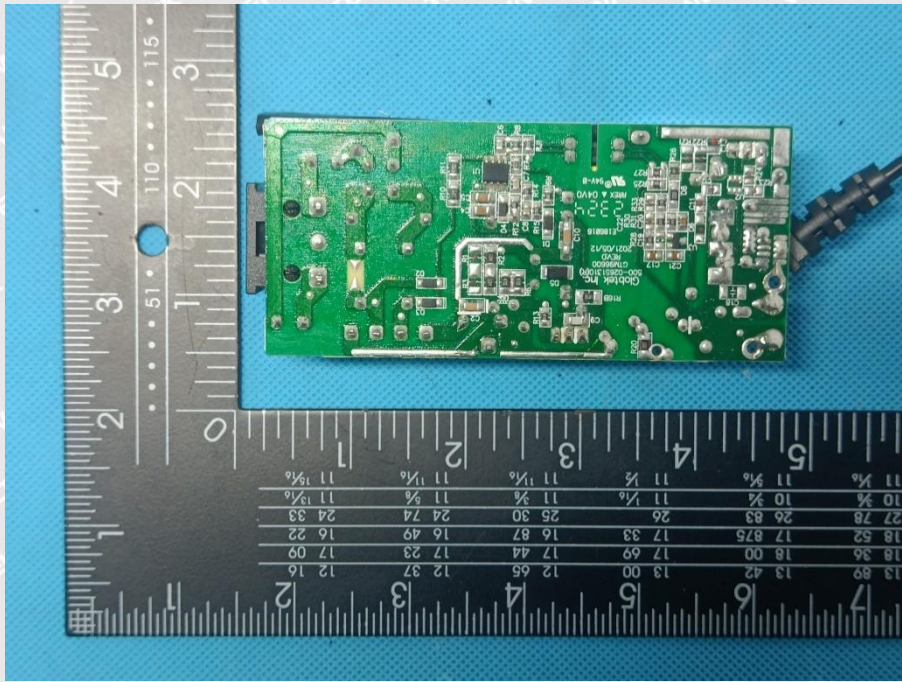

WALTEK

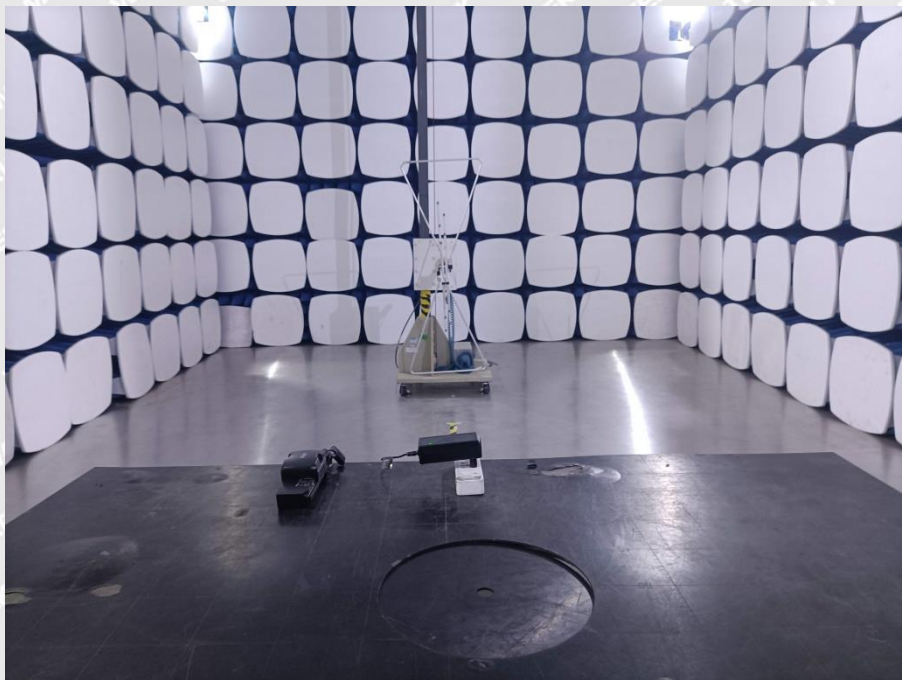

EXHIBIT 3 - TEST SETUP PHOTOGRAPHS

Conduction Emission Test View



Radiation Emission Test View





Harmonic/Flicker Test View



EN 61000-4-2 Test View





Reference No.: WTX23X08183427E001

EN 61000-4-3 Test View



WALTEK

EN 61000-4-4/5/11 Test View





Reference No.: WTX23X08183427E001

EN 61000-4-6 Test View



WALTEK

EN 61000-4-8 Test View



******* END OF REPORT *******