



中国认可
国际互认
检测
TESTING
CNAS L3110



TEST REPORT

Reference No..... : WTX23D10218937Z002
 Applicant..... : GlobTek, Inc.
 Address..... : 186 Veterans Dr. Northvale, NJ 07647 USA
 Manufacturer..... : GlobTek, Inc.
 Address..... : 186 Veterans Dr. Northvale, NJ 07647 USA
 Product Name..... : Blades-R
 Model No..... : R-NA-3
 Ratings..... : N/A
 Standards..... : UL 1310:2018 Ed.7+R:16Aug2019, UL 62368-1:2019
 Test Item..... : See list of test item
 Date of Receipt sample..... : 2023-10-18
 Date of Test..... : 2023-10-18 to 2023-11-15
 Date of Issue..... : 2023-11-20
 Test Result..... : The submitted samples comply with the above standards

Remarks:

The results shown in this test report refer only to the sample(s) tested, this test report cannot be reproduced, except in full, without prior written permission of the company. The report would be invalid without specific stamp of test institute and the signatures of compiler and approver.

Prepared By:

Waltek Services (Shenzhen) Co., Ltd.

Address: 1/F, Fukangtai Building, West Baima Rd., Songgang Street, Baoan District,
 Shenzhen, Guangdong, China
 Tel :+86-755-83551033
 Fax:+86-755-83552400

Compiled by:

Dave Feng

 Dave Feng /Project Engineer

Approved by:

Sam Qi

 Sam Qi /Designated Reviewer



List of test items:

No.	Test Items	Requirement + Test	Result
1	WEIGHT AND MOMENT DETERMINATION	UL 1310: 2017 Clause 7.11	Pass
2	BLADE SECUREMENT TEST	UL 1310: 2017 Clause 43	Pass
3	SECURITY OF INPUT CONTACTS	UL 1310: 2017 Clause 44	Pass
4	ROD PRESSURE TEST	UL 1310: 2017 Clause 46.4	Pass
5	DIRECT PLUG-IN RESISTANCE TO CRUSHING	UL 1310: 2017 Clause 46.5	Pass
6	DIRECT PLUG IN EQUIPMENT-MOMENT TEST	UL 62368-1 4.7	Pass

Subcontract

Whether parts of tests for the product have been subcontracted to other labs: Yes No

If Yes, list the related test items and lab information: Test items: ---

Lab information: --

Name and address of factory (ies) :

1: GlobTek, Inc. 186 Veterans Dr. Northvale, NJ 07647 USA
2: GlobTek (Suzhou) Co., Ltd Building 4, No. 76, Jin Ling East Rd., Suzhou Industrial Park, Suzhou, JiangSu 215021, China

Remarks:

The product with models R-NA-3 is Plug with detachable US plug and connector.
The maximum ambient temperature specified by manufacturer is 40°C
Connector on detachable plug part with adaptor has been tested with the appliance according to IEC 60320-1:2021 see report No. WTX23D10218937Z001



UL 1310			
Clause	Requirement – Test	Result – Remark	Verdict

Equipment's combined with two-pole plug (Class II)**Supplementary tests on plug portion are according to ANSI/UL 1310**

1	Dimensions		P
1.1	Checked according to NEMA WD 6-2002 figure 1-15		P
1.2	Checked according to figure 7.1, 7.5, sub-clauses 7.11, 7.16 of ANSI/UL 1310	(see appended table)	P
2	Direct Plug-In Blade Secureness Test		P
2.1	Each blade subject to pull test (89N / 2 min) and then two blade subject to pull test (89N / 2min) together. The displacement of each blade shall not exceed 2.4 mm measured 2 minute after remove the weight. (clause 43 of ANSI/UL 1310)	(see appended table)	P
3	Direct Plug-In Security of Input Contacts Test		P
3.1	Push test of each blade (133N / 1 min); (clause 44.1.2 of ANSI/UL 1310)	(see appended table)	P
3.2	Then the same specimen subject to push test of all blades (178N / 1 min); (clause 44.1.3 of ANSI/UL 1310) The blades shall not loosen.	(see appended table)	P
3.3	Folding and retracting blades subject to 6000 cycle rotating		N
3.4	After test, it shall a) Be operational b) Not expose live part c) Not influence plug and unplug to receptacle d) Comply with test of clause 43, 44.1.2, 44.1.3 e) Not alter the temperature rise of blade contact under normal operation		N
4	Resistance to crushing on direct plug-in units (clause 46.5.1 of ANSI/UL 1310)		P
	A sample of each model tabulated below		P



UL 1310			
Clause	Requirement – Test	Result – Remark	Verdict
	was placed between two maple blocks each not less than 1/2 in. thick and one having slots for the plug blades. A crushing force of 75 lb was applied gradually in a direction normal to the mounting surface for a period of 1 minute.		
	There was no splitting, cracking or shattering of the enclosure that would expose internal wiring or hazardous live parts.		P
5	Rod pressure on direct plug-in units(clause 46.4 of ANSI/UL 1310)		P
	A force increasing from 0 to 20 pounds-force (0 to 89 N) over a time period of 5 seconds was applied through the axis of a rod perpendicular to the surface of the enclosure. The rod was 1/2 in. (12.7 mm) diameter, having a flat contact end with the edge rounded to a radius of 1/32 in. (0.8 mm) to eliminate sharp edges. The force was maintained at 20 pounds for 1 minute.		P
	During this test, peak voltage and touch current were monitored between earth ground and all parts of the enclosure (the outer foil wrap). If the Peak Voltage was less than 42.4 V, then the Leakage Current was not measured. Following the test, the sample was subjected to the Electric Strength Test.		P
6	DIRECT PLUG- IN EQUIPMENT-MOMENT TEST (Clause 4.3.6 UL60950)		P
	Torque		P
	Compliance with the relevant mains plug standard:		P



1-WEIGHT AND MOMENT DETERMINATION: (DIRECT PLUG-IN UNIT) (clause 7.11, UL1310)

METHOD

The output cord was not included in the weight measurement.

Each sample was weighed and the distance to the center of gravity was measured using suitable instruments. The distance between the center of the blades and the center of gravity was measured. The moments were then calculated by taking the products of the above measurements.

W = Weight of the device.

S = The lesser of S₁ and S₂.

S₁ = Distance from the center of the blades to the left side of the enclosure.

S₂ = Distance from the center of the blades to the right side of the enclosure.

X = The greater of X₁ and X₂.

X₁ = Distance from the horizontal axis passing through the center of the blades to the center of gravity.

X₂ = Distance from the vertical axis passing through the center of the blades to the center of gravity.

Y = Distance from the face [blade side] to the center of gravity.

Z = The lesser of Z₁ and Z₂.

Z₁ = Distance from the center of the blades to the top of the enclosure.

Z₂ = Distance from the center of the blades to the bottom of the enclosure.

WEIGHT AND MOMENT DETERMINATION: (DIRECT PLUG-IN UNIT) (CONT'D)

RESULTS

Values are in grams or millimeters.

Model	W	S	X	Y	Z	WY/Z	WY/S	WX
R-NA-3	234g	26.5mm	30.19mm	13.86mm	17.91mm	181.1g	122.4g	0.069Nm

W did not exceed 794 grams, WY/Z did not exceed 1361 grams, WY/S did not exceed 1361 grams, and WX did not exceed 0.56 Nm (57606 gram-millimeters).



2 - DIRECT PLUG-IN BLADE SECUREMENT TEST(clause 43, UL1310)

Model	Displacement (mm)			
	Blade 1	Blade 2	Grounding Pin	Blade 1 and 2
R-NA-3	0.01	0.01	--	0.01

The blades did not loosen by more than 2.4 mm or pull out.

3 - DIRECT PLUG-IN SECURITY OF INPUT CONTACTS(clause 44, UL1310)

Model	Displacement (mm)		
	Blade 1	Blade 2	Both Blades
R-NA-3	0.01	0.01	0.01

The blades did not loosen to a degree that would introduce a risk of a fire or an electric shock.

4 - DIRECT PLUG-IN ROD PRESSURE TEST(clause 46.4, UL1310)

Model	Rod Pressure Point	Voltage (Vpk)	Touch Current Required?
R-NA-3	Center of enclosure face closest to transformer	23.8V	Yes

SINGLE-PHASE EQUIPMENT - Figure 5A.

The test was made in all combinations to the normal and reverse polarity of the supply circuit (Polarity Switch P1).

Terminal A (Switch "s") of Measuring Instrument Connected to:	Switch "e" Position	Touch Current (mA r.m.s.)			
		Polarity P1/Primary Switch Condition			
		Normal/On	Normal/Off	Reverse/On	Reverse/Off
Enclosure with metal foil	--	0.018	--	0.020	--

The touch current did not exceed 0.25 mA r.m.s with terminal A connected to the earth terminal of the unit with Switch "e" closed.



5 - DIRECT PLUG-IN RESISTANCE TO CRUSHING(clause 46.5, UL1310)

Model	Observations
R-NA-3	No cracking. Intact

There was no splitting, cracking or shattering of the enclosure that would expose internal wiring or hazardous live parts.

6- DIRECT PLUG IN EQUIPMENT-MOMENT TEST(4.7, UL 62368-1)

4.7 Torque test for equipment for direct insertion into mains socket-outlets				<input type="checkbox"/> N/A <input type="checkbox"/> Fail <input checked="" type="checkbox"/> Pass		
Test Requirement:						
<i>The additional torque from plug-in equipment applied to the socket-outlet shall not exceed 0,25 Nm</i>						
Remark (additional info or observation during the test):						
<i>Torque(to maintain the engagement face in vertical plane) = Force(N) X Distance(mm) X 0.001</i>						
Plug type	Orientation	Torque (Nm)			Result	
		Force (N)	Distance (mm)	Calculated Torque (Nm)	Pass	Fail
US plug	<input checked="" type="checkbox"/> Normal	0.49	58	0.028	(√)	()
	<input type="checkbox"/> Reverse					
	<input type="checkbox"/> Normal	0.49	61	0.030	(√)	()
	<input checked="" type="checkbox"/> Reverse					
Supplementary information: --						



Dimension Checking for Three-pin plugs of NA (15 A, 125V)
According to (NEMA WD 6-2002 Figure 5-15)

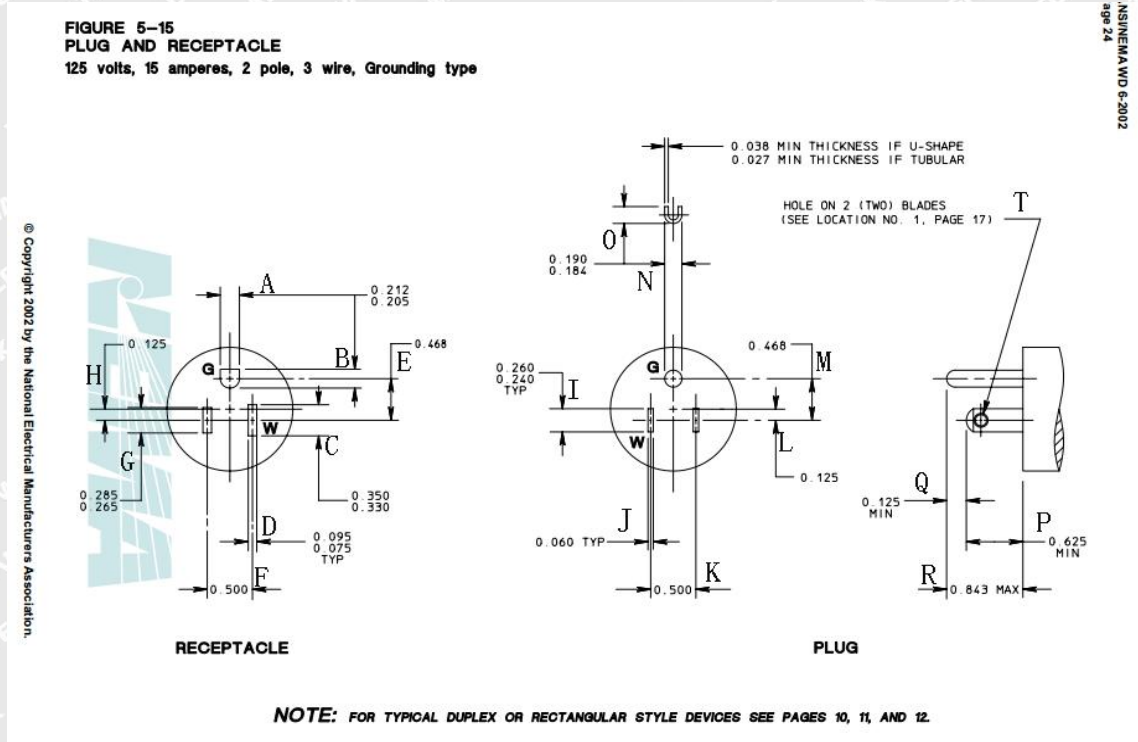

For non-polarity plug					
Symb ol	Requirement (inch)	Measured (inch)	Symb ol	Requirement (inch)	Measured (inch)
I	0.240-0.260	0.245	O	0.184-0.190	--
J	0.055-0.065	0.056	P	0.625-0.718	0.638
K	0.500±0.001	0.501	Q	0.125±0.001	0.125
L	0.125±0.001	0.128	R	0.843±0.001	0.843
M	0.468±0.001	0.4691	T	0.125	0.125
N	0.184-0.190	0.1871			
Perimeter faces to the plug blades shall not be less than 7.9 mm (intended for use with children's toys) or 5.1 mm from any point of either blade					8.50mm
For CSA standard CSA C22.2 No 223, clause 4.5.1.4					



Photo Documentation:

Model: R-NA-3

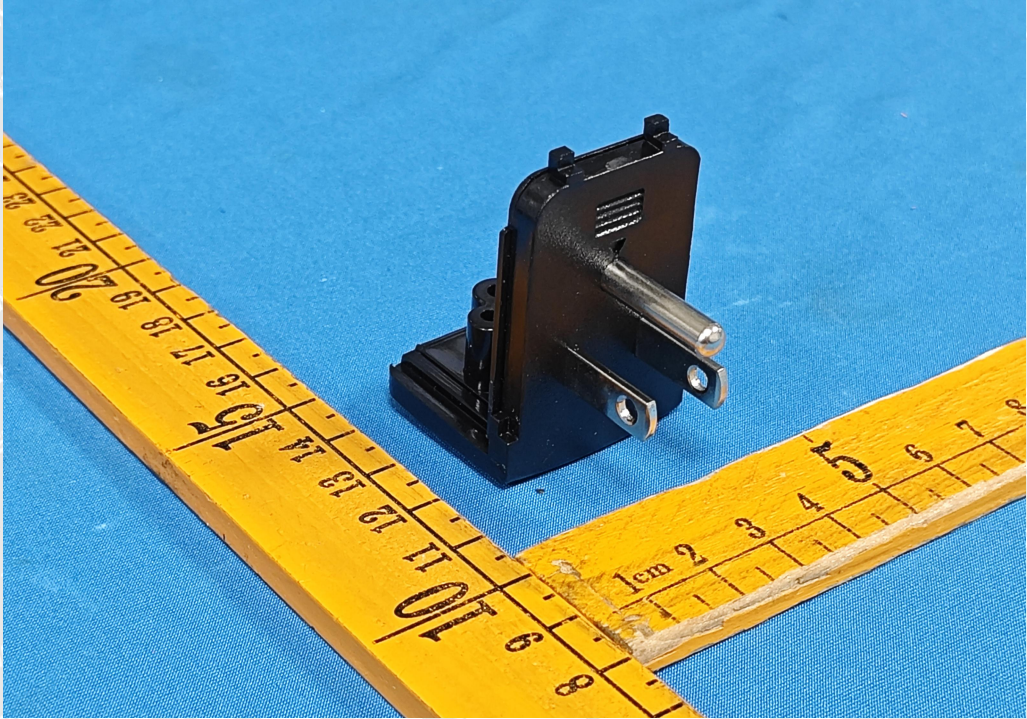

Photo 1

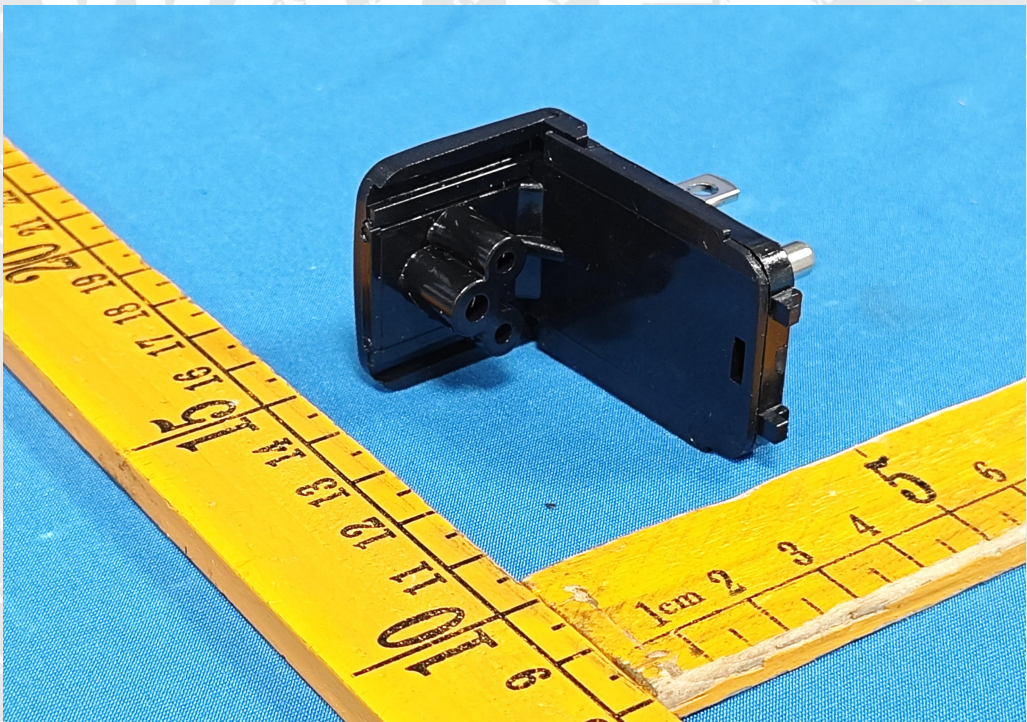

Photo 2

====End of Report====