



Test Report issued under the responsibility of



www.nemko.com

TEST REPORT
IEC 60950-1
Information technology equipment – Safety –
Part 1: General requirements

Report Number: 232812
Date of issue: 2013-04-19
Total number of pages: 52 Pages, refer to page 3 for List of attachments
CB Testing Laboratory.....: Nemko Shanghai Ltd Phone: +86 21 5445 3132
Address: 7th Floor, Building 1, No.2007 Hongmei Road Xuhui District, Shanghai, China

Applicant's name.....: GlobTek, Inc.
Address: 186 Veterans Dr. Northvale, NJ 07647 USA

Manufacturer's name.....: GlobTek, Inc.
Address: 186 Veterans Dr. Northvale, NJ 07647 USA

Test specification:
Standard: IEC 60950-1:2005(Second Edition) + Am 1:2009
Test procedure: CB Scheme
Non-standard test method.....: N/A

Test Report Form No.....: IEC60950_1C
Test Report Form(s) Originator.....: SGS Fimko Ltd
Master TRF: Dated 2012-08

Copyright © 2012 Worldwide System for Conformity Testing and Certification of Electrotechnical Equipment and Components (IECEE), Geneva, Switzerland. All rights reserved.

This publication may be reproduced in whole or in part for non-commercial purposes as long as the IECEE is acknowledged as copyright owner and source of the material. IECEE takes no responsibility for and will not assume liability for damages resulting from the reader's interpretation of the reproduced material due to its placement and context.

If this Test Report Form is used by non-IECEE members, the IECEE/IEC logo and the reference to the CB Scheme procedure shall be removed.

This report is not valid as a CB Test Report unless signed by an approved CB Testing Laboratory and appended to a CB Test Certificate issued by an NCB in accordance with IECEE 02.

Test item description: ITE power adaptor for build in
Trade Mark: GlobTek, Inc.
Manufacturer: GlobTek, Inc.
Model/Type reference: GT-93020-0324
Ratings: I/P: 2.0A, AC 24V, 50-60Hz
O/P: DC 24V, 0.125A, 1A PEAK

TRF No. IEC60950_1C

This Test Report, when bearing the Nemko name and logo is only valid when issued by a Nemko laboratory, or by a laboratory having special agreement with Nemko.

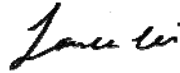
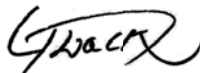
Testing procedure and testing location:		
<input checked="" type="checkbox"/>	CB Testing Laboratory:	Nemko Shanghai Ltd
Testing location/ address		7 th Floor, Building 1, No.2007 Hongmei Road Xuhui District, Shanghai, China
<input type="checkbox"/>	Associated CB Laboratory:	
Testing location/ address		
Tested by (name + signature)		Lance Lei 
Approved by (name + signature)		Sam-Geun Gwack 
<input type="checkbox"/>	Testing procedure: TMP	
Testing location/ address		
Tested by (name + signature)		
Approved by (name + signature)		
<input type="checkbox"/>	Testing procedure: WMT	
Testing location/ address		
Tested by (name + signature)		
Witnessed by (name + signature)		
Approved by (name + signature)		
<input type="checkbox"/>	Testing procedure: SMT	
Testing location/ address		
Tested by (name + signature)		
Approved by (name + signature)		
Supervised by (name + signature)		
<input type="checkbox"/>	Testing procedure: RMT	
Testing location/ address		
Tested by (name + signature)		
Approved by (name + signature)		
Supervised by (name + signature)		

List of Attachments (including a total number of pages in each attachment):

- Attachment 1: Photos (4 pages)
- Attachment 2: PCB layout (1 page)
- Attachment 3: Transformer specification(1 page)
- Attachment 4: European Group Differences and National Differences EN 60950-1:2006/A11:2009/A1:2010/ A12:2011(17 pages)
- Attachment 5: National Differences
Australia/New Zealand (8 pages), Canada (5 pages), China (6 pages), Israel (4 pages), Japan (12 pages), Korea (1 page), Singapore (3 pages), USA (5 pages).
- Attachment 6: IP test report (5 pages)

Summary of testing:

<p>Compliance with the EMC directive is necessary for achieving type certification. The appliance shall comply with the relevant EMC standards, depending on the equipment in question. In NO, compliance with standards for radio interference suppression is a part of Nemko's certification. In FI, DK and SE compliance is not necessary for achieving safety certification.</p>	<p>EMC is based on self declaration according to EMC Directive 2004/108/EC.</p>
<p>1.4.10 Loading configuration of the EUT</p>	<p>The 1A peak on output rating didn't simulate and evaluate in this test report. If necessary, it shall evaluate in the end product. The unit is to power a GSM (Global System for Mobile Communications) module: during communication set up, 1A bursts are emitted for 5 minutes max. per hour. The 1A peaks duration is 1ms, followed by a 4ms period with 125mA max.</p>
<p>2.10.3 / 2.10.4 Transient overvoltage, Clearance and Creepage distance measurements</p>	<p>The equipment not connected to AC mains supply directly. But transient overvoltage 2500V assumed as the worst case. The equipment complied with double/reinforced insulation between input and output circuit base on measured working voltage.</p>
<p>3.2 Connection to a mains supply</p>	<p>Built-in equipment and not connected to AC mains supply directly. Compliance shall evaluated with the end-product.</p>
<p>4.7 Resistance to fire</p>	<p>Components and materials have adequate flammability classification. The fire enclosure is of flame class min. V-1 material. Built-in equipment, compliance of input terminal part shall be evaluated with the end-product.</p>
<p>Annex T Guidance on protection against ingress of water</p>	<p>The equipment excluding input connector and output connector complied with IP21. IPX0 is for this equipment.</p>

Tests performed (name of test and test clause): 1.6.2; Input current 1.7.11; Durability test 2.2.2, 2.2.3; SELV reliability circuits 2.4; Limited current circuits 2.5; Limited power sources 2.9; Electrical insulation 2.10.2; Determination of working voltage 2.10.3, 2.10.4; Clearance and creepage distance Measurements 2.10.5; Distance through insulation measurements 4.2; Mechanical strength 4.5.2; Temperature test 4.5.5; Ball pressure test of thermoplastic parts 5.2; Electric strength 5.3; Abnormal operation and fault conditions Annex C Annex T	Testing location: Refer to page 2
Summary of compliance with National Differences List of countries addressed: All CENELEC members as listed in EN 60950-1:2006/A11:2009/A1:2010/A12:2011. CB members listed in the IECEE Online Bulletin included: Australia/ New Zealand, Canada, China, Israel, Japan, Korea, Singapore and USA which attached separate as national deviation report in this report. At the time of issuing this report, not all countries are listed for IEC 60950-1:2005 (ed.2, Am1:2009). Therefore this report includes National differences to IEC 60950-1:2001(ed.1) and IEC 60950-1:2005(ed.2). <input checked="" type="checkbox"/> The product fulfils the requirements of IEC 60950-1:2005 (2nd Edition); Am1: 2009 and EN 60950-1:2006/A11:2009/A1:2010/A12:2011.	

Copy of marking plate

The artwork below may be only a draft. The use of certification marks on a product must be authorized by the respective NCBS that own these marks.

(Additional requirements for markings. See 1.7 NOTE)

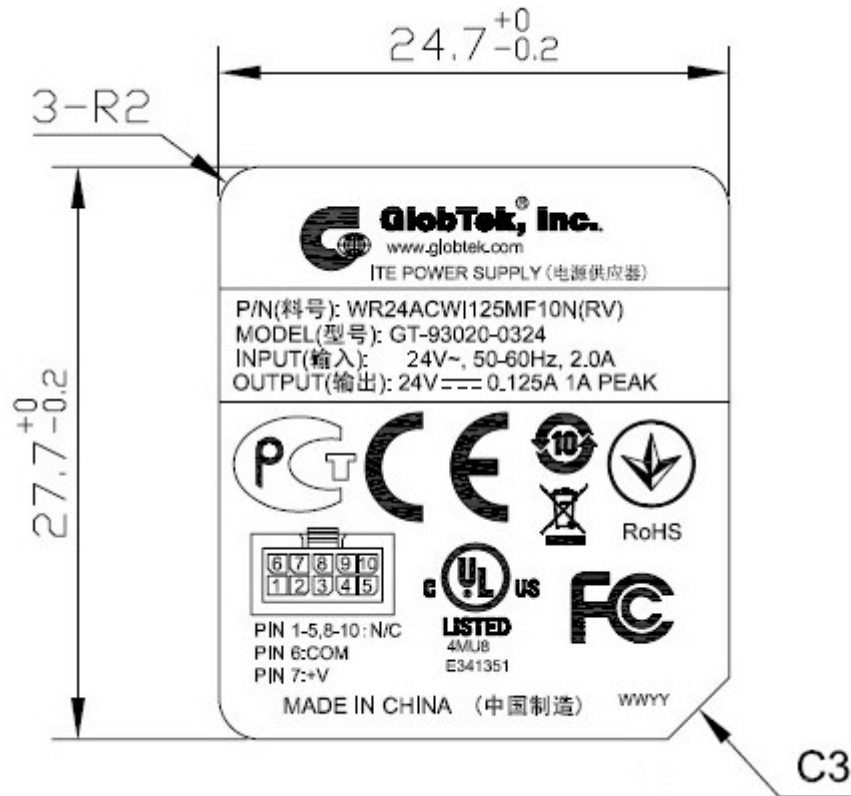

<p>Calibration:</p>	<p>All instruments used in the tests given in this test report are calibrated and traceable to national or international standards.</p> <p>Further information about traceability will be given on request.</p>
<p>Measurement uncertainty:</p>	<p>Measurement uncertainties are calculated for all instruments and instrument set-ups given in this report. Calculations are based on the principles given in the standard EA-4/02 (Dec. 1999), IEC Guide 115:2007, Nemko routine L227 and other relevant internal Nemko-procedures.</p> <p>Further information about measurement uncertainties will be given on request.</p>
<p>Evaluation of results:</p>	<p>If not explicitly stated otherwise in the standard, the test is passed if the measured value is equal to or below (above) the limit line, regardless of the measurement uncertainty. If the measured value is above (below) the limit line, the test is not passed - ref IEC Guide 115:2007, and Nemko routine L220. The instrumentation accuracy is within limits agreed by IEC EE-CTL (ref. Nemko routine L227).</p>

Test item particulars:	
Equipment mobility.....:	<input type="checkbox"/> movable <input type="checkbox"/> hand-held <input type="checkbox"/> transportable <input type="checkbox"/> stationary <input checked="" type="checkbox"/> for building-in <input type="checkbox"/> direct plug-in
Connection to the mains.....:	<input type="checkbox"/> pluggable equipment <input type="checkbox"/> type A <input type="checkbox"/> type B <input type="checkbox"/> permanent connection <input type="checkbox"/> detachable power supply cord <input type="checkbox"/> non-detachable power supply cord <input checked="" type="checkbox"/> not directly connected to the mains
Operating condition.....:	<input checked="" type="checkbox"/> continuous <input type="checkbox"/> rated operating / resting time:
Access location	<input checked="" type="checkbox"/> operator accessible <input type="checkbox"/> restricted access location
Over voltage category (OVC)	<input type="checkbox"/> OVC I <input checked="" type="checkbox"/> OVC II <input type="checkbox"/> OVC III <input type="checkbox"/> OVC IV <input type="checkbox"/> other:
Mains supply tolerance (%) or absolute mains supply values	+42%, -33% (declared by manufacturer)
Tested for IT power systems	<input type="checkbox"/> Yes <input checked="" type="checkbox"/> No
IT testing, phase-phase voltage (V)	N/A
Class of equipment	<input type="checkbox"/> Class I <input checked="" type="checkbox"/> Class II <input type="checkbox"/> Class III <input type="checkbox"/> Not classified
Considered current rating of protective device as part of the building installation (A)	N/A
Pollution degree (PD)	<input type="checkbox"/> PD 1 <input checked="" type="checkbox"/> PD 2 <input type="checkbox"/> PD 3
IP protection class	IPX0
Altitude during operation (m)	<2000m
Altitude of test laboratory (m)	<2000m
Mass of equipment (kg)	0.121kg Dimension (W x H x D): 30 x 74 x 55mm (excluding the output wire and connector)
Possible test case verdicts:	
- test case does not apply to the test object.....:	N/A
- test object does meet the requirement.....:	P (Pass)
- test object does not meet the requirement	F (Fail)
Testing:	
Date of receipt of test item.....:	2013.03.01
Date(s) of performance of tests.....:	2013.03.21 - 2013.04.07
General remarks:	
The test results presented in this report relate only to the object tested. This report shall not be reproduced, except in full, without the written approval of the Issuing testing laboratory. "(see Enclosure #)" refers to additional information appended to the report. "(see appended table)" refers to a table appended to the report. Throughout this report a <input type="checkbox"/> comma / <input checked="" type="checkbox"/> point is used as the decimal separator.	

Manufacturer's Declaration per sub-clause 6.2.5 of IECEE 02:

The application for obtaining a CB Test Certificate includes more than one factory location and a declaration from the Manufacturer stating that the sample(s) submitted for evaluation is (are) representative of the products from each factory has been provided: Yes Not applicable

When differences exist; they shall be identified in the General product information section.

Name and address of factory (ies)..... :

1. GlobTek (Suzhou) Co., Ltd
Building 4, No. 76, Jin Ling East Rd., Suzhou Industrial Park, Suzhou, JiangSu 215021, China
2. GlobTek, Inc.
186 Veterans Dr. Northvale, NJ 07647 USA

General product information:

The equipment GT-93020-0324 is a built-in ITE power adaptor for using on construction sites in a closed rack enclosure. The unit is to power a GSM (Global System for Mobile Communications) module: during communication set up, 1A bursts are emitted for 5 minutes max. per hour. The 1A peaks duration is 1ms, followed by a 4ms period with 125mA max.

Max. normal load condition: Output load to rated output.

Max. recommended operating ambient (Tma): 65°C.

Circuit characteristics: The equipment not directly connected to AC mains supply and all circuits in the equipment considered as secondary circuits. The output of equipment is SELV circuit.

1.1.2 – Additional requirements:

Exposure to extreme temperatures, excessive dust, moisture or vibration; to flammable gases; to corrosive or explosive atmospheres:

This equipment is intended to operate in a "normal" environment (Offices and homes).

Electromedical equipment connected to the patient:

This equipment is not an electromedical equipment intended to be physically connected to a patient.

Equipment used in vehicles, ships or aircrafts, in tropical countries, or at elevations > 2000m:

This equipment is intended to operate in a "normal" environment (Offices and homes).

Abbreviations used in the report:

- normal conditions	N.C.	- single fault conditions	S.F.C
- functional insulation	OP	- basic insulation	BI
- double insulation	DI	- supplementary insulation SI	
- between parts of opposite polarity	BOP	- reinforced insulation	RI

Indicate used abbreviations (if any)



IEC 60950-1/Am1			
Clause	Requirement + Test	Result - Remark	Verdict
1	GENERAL		P
1.5	Components		P
1.5.1	General	Refer below.	P
	Comply with IEC 60950-1 or relevant component standard	(see appended tables 1.5.1)	P
1.5.2	Evaluation and testing of components	<p>Certified components are used in accordance with their ratings, certifications and they comply with applicable parts of this standard.</p> <p>Components not certified are used in accordance with their ratings and they comply with applicable parts of IEC 60950-1 and the relevant component standard.</p> <p>Components, for which no relevant IEC-standard exists, have been tested under the conditions occurring in the equipment, using applicable parts of IEC 60950-1.</p>	P
1.5.3	Thermal controls	No such devices.	N/A
1.5.4	Transformers	Transformers used are suitable for it's intended application and comply with relevant parts of this standard and particularly Annex C, see Annex C – Transformers.	P
1.5.5	Interconnecting cables	Interconnection output cables are carrying only SELV voltages. Except for the insulation material, there are no further requirements to the output cables.	P



IEC 60950-1/Am1			
Clause	Requirement + Test	Result - Remark	Verdict
1.5.6	Capacitors bridging insulation	No primary circuit in this equipment. Circuits in this equipment considered as secondary circuits. X2(CX1) capacitors are used between lines. Y1(CY1) capacitor used for bridging reinforced insulation. Refer to appended table 1.5.1. X2, Y1 capacitors are certified according to IEC/EN60384-14. Refer to appended table 1.5.1 and circuits complies with 2.4 shall evaluate with the end-product.	P
1.5.7	Resistors bridging insulation	Refer below.	P
1.5.7.1	Resistors bridging functional, basic or supplementary insulation	Discharge resistors are located after fuse bridging functional insulation.	P
1.5.7.2	Resistors bridging double or reinforced insulation between a.c. mains and other circuits	No resistor bridging double or reinforced insulation.	N/A
1.5.7.3	Resistors bridging double or reinforced insulation between a.c. mains and antenna or coaxial cable	No resistor bridging double or reinforced insulation.	N/A
1.5.8	Components in equipment for IT power systems	Equipment not directly connected to AC power distribution system.	N/A
1.5.9	Surge suppressors	Certified MOV located after fuse F1 bridging two opposite polarity lines. See appended table 1.5.1.	P
1.5.9.1	General	See below.	P
1.5.9.2	Protection of VDRs	Fuse F1 for protecting MOV.	P
1.5.9.3	Bridging of functional insulation by a VDR		P
1.5.9.4	Bridging of basic insulation by a VDR	No such application.	N/A
1.5.9.5	Bridging of supplementary, double or reinforced insulation by a VDR	No such application.	N/A

1.6	Power interface		P
1.6.1	AC power distribution systems	Equipment not directly connected to AC power distribution system.	N/A
1.6.2	Input current	(see appended table 1.6.2)	P



IEC 60950-1/Am1			
Clause	Requirement + Test	Result - Remark	Verdict
1.6.3	Voltage limit of hand-held equipment	The equipment is not hand-held.	N/A
1.6.4	Neutral conductor	Equipment not directly connected to AC power distribution system.	N/A

1.7	Marking and instructions		P
1.7.1	Power rating and identification markings		P
1.7.1.1	Power rating marking	The power rating marking is posted on the outside of the enclosure.	P
	Multiple mains supply connections.....:	Equipment not directly connected to mains supply.	N/A
	Rated voltage(s) or voltage range(s) (V)	24V	P
	Symbol for nature of supply, for d.c. only	AC supply.	N/A
	Rated frequency or rated frequency range (Hz) ... :	50-60Hz	P
	Rated current (mA or A)	2.0A	P
1.7.1.2	Identification markings		P
	Manufacturer's name or trade-mark or identification mark	GlobTek, Inc	P
	Model identification or type reference	GT-93020-0324	P
	Symbol for Class II equipment only		N/A
	Other markings and symbols	Other markings and symbols do not give rise to misunderstanding.	P
1.7.2	Safety instructions and marking		P
1.7.2.1	General	Safety relevant contents comply with IEC/EN 60950-1 are include.	P
1.7.2.2	Disconnect devices	Built-in equipment, compliance shall be evaluated in the end-product.	N/A
1.7.2.3	Overcurrent protective device	Built-in equipment, compliance shall be evaluated in the end-product.	N/A
1.7.2.4	IT power distribution systems	Equipment not directly connected to AC power distribution system.	N/A
1.7.2.5	Operator access with a tool	Built-in equipment, compliance shall be evaluated in the end-product.	N/A



IEC 60950-1/Am1			
Clause	Requirement + Test	Result - Remark	Verdict
1.7.2.6	Ozone	The equipment does not produce ozone.	N/A
1.7.3	Short duty cycles	Continuous operation.	N/A
1.7.4	Supply voltage adjustment	Single voltage.	N/A
	Methods and means of adjustment; reference to installation instructions		N/A
1.7.5	Power outlets on the equipment	No power outlets provided.	N/A
1.7.6	Fuse identification (marking, special fusing characteristics, cross-reference)	PCB-mount fuse: F1: T2A, 250Vac.	P
1.7.7	Wiring terminals	Built-in equipment, compliance shall be evaluated in the end product.	N/A
1.7.7.1	Protective earthing and bonding terminals		N/A
1.7.7.2	Terminals for a.c. mains supply conductors		N/A
1.7.7.3	Terminals for d.c. mains supply conductors	AC input.	N/A
1.7.8	Controls and indicators	See below.	N/A
1.7.8.1	Identification, location and marking	No indicator, switches and other controls affecting safety.	N/A
1.7.8.2	Colours		N/A
1.7.8.3	Symbols according to IEC 60417	No switch.	N/A
1.7.8.4	Markings using figures		N/A
1.7.9	Isolation of multiple power sources	Single supply.	N/A
1.7.10	Thermostats and other regulating devices	No such regulating devices.	N/A
1.7.11	Durability	The marking withstands required tests.	P
1.7.12	Removable parts	No such parts.	N/A
1.7.13	Replaceable batteries	No battery.	N/A
	Language(s)		—
1.7.14	Equipment for restricted access locations.....	Built-in equipment, compliance shall be evaluated with the end-product.	N/A

2	PROTECTION FROM HAZARDS		P
2.1	Protection from electric shock and energy hazards		P
2.1.1	Protection in operator access areas	Built-in equipment, compliance shall be evaluated with the end-product.	N/A



IEC 60950-1/Am1			
Clause	Requirement + Test	Result - Remark	Verdict
2.1.1.1	Access to energized parts	Built-in equipment, compliance shall be evaluated with the end-product.	N/A
	Test by inspection		N/A
	Test with test finger (Figure 2A)		N/A
	Test with test pin (Figure 2B)		N/A
	Test with test probe (Figure 2C)		N/A
2.1.1.2	Battery compartments	No battery.	N/A
2.1.1.3	Access to ELV wiring	No ELV wiring in operator accessible area.	N/A
	Working voltage (V_{peak} or V_{rms}); minimum distance through insulation (mm)	(see appended tables 2.10.2 and 2.10.5)	—
2.1.1.4	Access to hazardous voltage circuit wiring	Built-in equipment, compliance shall be evaluated with the end-product.	N/A
2.1.1.5	Energy hazards	Built-in equipment, compliance shall be evaluated with the end-product. See appended table 2.1.1.5c) for reference.	N/A
2.1.1.6	Manual controls	No such controls.	N/A
2.1.1.7	Discharge of capacitors in equipment		P
	Measured voltage (V); time-constant (s)	See appended table 2.1.1.7.	—
2.1.1.8	Energy hazards – d.c. mains supply	Not intended for connecting to d.c. mains supply.	N/A
	a) Capacitor connected to the d.c. mains supply . :		N/A
	b) Internal battery connected to the d.c. mains supply		N/A
2.1.1.9	Audio amplifiers	No audio amplifiers.	N/A
2.1.2	Protection in service access areas	Built-in equipment, compliance shall be evaluated with the end-product.	N/A
2.1.3	Protection in restricted access locations	Built-in equipment, compliance shall be evaluated with the end-product.	N/A



IEC 60950-1/Am1			
Clause	Requirement + Test	Result - Remark	Verdict
2.2	SELV circuits		P
2.2.1	General requirements	SELV limits are not exceeded under normal condition and after a single fault. See appended table 2.2.	P
2.2.2	Voltages under normal conditions (V)	Within SELV limits.	P
2.2.3	Voltages under fault conditions (V)	Within SELV limits.	P
2.2.4	Connection of SELV circuits to other circuits	Built-in equipment, for SELV circuit connected to other circuit outside the equipment, shall be evaluated in the end product.	N/A
2.3	TNV circuits		N/A
2.3.1	Limits	No TNV circuits.	N/A
	Type of TNV circuits		—
2.3.2	Separation from other circuits and from accessible parts		N/A
2.3.2.1	General requirements		N/A
2.3.2.2	Protection by basic insulation		N/A
2.3.2.3	Protection by earthing		N/A
2.3.2.4	Protection by other constructions		N/A
2.3.3	Separation from hazardous voltages		N/A
	Insulation employed.....		—
2.3.4	Connection of TNV circuits to other circuits		N/A
	Insulation employed.....		—
2.3.5	Test for operating voltages generated externally		N/A
2.4	Limited current circuits		P
2.4.1	General requirements	Y1 capacitor CY1 bridging the RI.	P
2.4.2	Limit values	(See appended table 2.4.2)	P
	Frequency (Hz).....		—
	Measured current (mA)		—
	Measured voltage (V)		—
	Measured circuit capacitance (nF or μ F).....		—



IEC 60950-1/Am1			
Clause	Requirement + Test	Result - Remark	Verdict
2.4.3	Connection of limited current circuits to other circuits	Output circuit as limited current circuit connected to input circuit via bridging component.	P

2.5	Limited power sources	(see appended table 2.5)	P
	a) Inherently limited output		N/A
	b) Impedance limited output		N/A
	c) Regulating network limited output under normal operating and single fault condition	DC output complies with limited power source.	P
	d) Overcurrent protective device limited output		N/A
	Max. output voltage (V), max. output current (A), max. apparent power (VA)	(see appended table 2.5)	—
	Current rating of overcurrent protective device (A) .:		—
	Use of integrated circuit (IC) current limiters		

2.6	Provisions for earthing and bonding		N/A
2.6.1	Protective earthing	Class II equipment.	N/A
2.6.2	Functional earthing		N/A
2.6.3	Protective earthing and protective bonding conductors		N/A
2.6.3.1	General		N/A
2.6.3.2	Size of protective earthing conductors		N/A
	Rated current (A), cross-sectional area (mm ²), AWG		—
2.6.3.3	Size of protective bonding conductors		N/A
	Rated current (A), cross-sectional area (mm ²), AWG		—
	Protective current rating (A), cross-sectional area (mm ²), AWG		N/A
2.6.3.4	Resistance of earthing conductors and their terminations; resistance (Ω), voltage drop (V), test current (A), duration (min)		N/A
2.6.3.5	Colour of insulation		N/A
2.6.4	Terminals		N/A
2.6.4.1	General		N/A
2.6.4.2	Protective earthing and bonding terminals		N/A



IEC 60950-1/Am1			
Clause	Requirement + Test	Result - Remark	Verdict
	Rated current (A), type, nominal thread diameter (mm)		—
2.6.4.3	Separation of the protective earthing conductor from protective bonding conductors		N/A
2.6.5	Integrity of protective earthing		N/A
2.6.5.1	Interconnection of equipment		N/A
2.6.5.2	Components in protective earthing conductors and protective bonding conductors		N/A
2.6.5.3	Disconnection of protective earth		N/A
2.6.5.4	Parts that can be removed by an operator		N/A
2.6.5.5	Parts removed during servicing		N/A
2.6.5.6	Corrosion resistance		N/A
2.6.5.7	Screws for protective bonding		N/A
2.6.5.8	Reliance on telecommunication network or cable distribution system		N/A

2.7	Overcurrent and earth fault protection in primary circuits		N/A
2.7.1	Basic requirements	No primary circuit in the equipment. Circuits in the equipment considered as secondary circuits. But protective device is integrated in the equipment, see also 5.3.	N/A
	Instructions when protection relies on building installation		N/A
2.7.2	Faults not simulated in 5.3.7		N/A
2.7.3	Short-circuit backup protection		N/A
2.7.4	Number and location of protective devices		N/A
2.7.5	Protection by several devices		N/A
2.7.6	Warning to service personnel.....		N/A

2.8	Safety interlocks		N/A
2.8.1	General principles	No safety interlock.	N/A
2.8.2	Protection requirements		N/A
2.8.3	Inadvertent reactivation		N/A
2.8.4	Fail-safe operation		N/A
	Protection against extreme hazard		N/A



IEC 60950-1/Am1			
Clause	Requirement + Test	Result - Remark	Verdict
2.8.5	Moving parts		N/A
2.8.6	Overriding		N/A
2.8.7	Switches, relays and their related circuits		N/A
2.8.7.1	Separation distances for contact gaps and their related circuits (mm)		N/A
2.8.7.2	Overload test		N/A
2.8.7.3	Endurance test		N/A
2.8.7.4	Electric strength test		N/A
2.8.8	Mechanical actuators		N/A

2.9	Electrical insulation		P
2.9.1	Properties of insulating materials	Natural rubber, asbestors or hygroscopic materials are not used.	P
2.9.2	Humidity conditioning	120h with the concurrence of manufacturer.	P
	Relative humidity (%), temperature (°C)	93%, 40°C.	—
2.9.3	Grade of insulation	Insulation is considered to be functional, basic, supplementary, reinforced or double insulation.	P
2.9.4	Separation from hazardous voltages	By double or reinforced insulation.	P
	Method(s) used	Method 1.	—

2.10	Clearances, creepage distances and distances through insulation		P
2.10.1	General	See below.	P
2.10.1.1	Frequency	Condidered.	P
2.10.1.2	Pollution degrees	Pollution degree 2.	P
2.10.1.3	Reduced values for functional insulation	Refer to Cl.5.3.4.	P
2.10.1.4	Intervening unconnected conductive parts	No such conductive parts.	N/A
2.10.1.5	Insulation with varying dimensions	No such insulation.	N/A
2.10.1.6	Special separation requirements	Not used.	N/A
2.10.1.7	Insulation in circuits generating starting pulses	No circuits generating starting pulses.	N/A
2.10.2	Determination of working voltage	See below.	P
2.10.2.1	General	See below.	P
2.10.2.2	RMS working voltage	(see appended table 2.10.2)	P



IEC 60950-1/Am1			
Clause	Requirement + Test	Result - Remark	Verdict
2.10.2.3	Peak working voltage	(see appended table 2.10.2)	P
2.10.3	Clearances	(see appended table 2.10.3 and 2.10.4)	P
2.10.3.1	General		P
2.10.3.2	Mains transient voltages		P
	a) AC mains supply	The equipment not directly connected to AC mains supply. Circuits in the equipment considered as secondary circuits. But transient overvoltage 2500V assumed as the worst case.	P
	b) Earthed d.c. mains supplies		N/A
	c) Unearthed d.c. mains supplies		N/A
	d) Battery operation		N/A
2.10.3.3	Clearances in primary circuits	(see appended table 2.10.3 and 2.10.4)	P
2.10.3.4	Clearances in secondary circuits	See Cl. 5.3.4.	P
2.10.3.5	Clearances in circuits having starting pulses	No circuits generating starting pulses.	N/A
2.10.3.6	Transients from a.c. mains supply	2500V peak considered as worst case.	P
2.10.3.7	Transients from d.c. mains supply	Not for d.c. mains supply.	N/A
2.10.3.8	Transients from telecommunication networks and cable distribution systems	No TNV circuit.	N/A
2.10.3.9	Measurement of transient voltage levels	Measurement not relevant.	N/A
	a) Transients from a mains supply		N/A
	For an a.c. mains supply		N/A
	For a d.c. mains supply		N/A
	b) Transients from a telecommunication network :		N/A
2.10.4	Creepage distances	(see appended table 2.10.3 and 2.10.4)	P
2.10.4.1	General	See below.	P
2.10.4.2	Material group and comparative tracking index	See below.	P
	CTI tests	Material group IIIb is used.	—
2.10.4.3	Minimum creepage distances	(see appended table 2.10.3 and 2.10.4)	P
2.10.5	Solid insulation	See below.	P
2.10.5.1	General	Considered.	P



IEC 60950-1/Am1			
Clause	Requirement + Test	Result - Remark	Verdict
2.10.5.2	Distances through insulation	(see appended table 2.10.5)	P
2.10.5.3	Insulating compound as solid insulation	No such devices.	N/A
2.10.5.4	Semiconductor devices	No such devices.	N/A
2.10.5.5.	Cemented joints	The optocoupler applied a). See appended table 1.5.1.	P
2.10.5.6	Thin sheet material – General	Considered.	P
2.10.5.7	Separable thin sheet material	See tables C.2, table 2.10.3 & 2.10.4 and table 5.2 for detail applicable.	P
	Number of layers (pcs)	Refer to appended tables C.2 and 5.2.	—
2.10.5.8	Non-separable thin sheet material		N/A
2.10.5.9	Thin sheet material – standard test procedure	Used alternative test procedure.	N/A
	Electric strength test		—
2.10.5.10	Thin sheet material – alternative test procedure		P
	Electric strength test	See appended table 5.2.	—
2.10.5.11	Insulation in wound components	Not used.	N/A
2.10.5.12	Wire in wound components	Triple insulated wire in pri.and sec. winding of T1.	P
	Working voltage		N/A
	a) Basic insulation not under stress		N/A
	b) Basic, supplementary, reinforced insulation		N/A
	c) Compliance with Annex U	(See appended table 1.5.1)	P
	Two wires in contact inside wound component; angle between 45° and 90°	The triple insulated wires are not crossing another wire in an angel between 45°and 90° prevented by tube.	P
2.10.5.13	Wire with solvent-based enamel in wound components	No wire with solvent-based enamel in wound components.	N/A
	Electric strength test		—
	Routine test		N/A
2.10.5.14	Additional insulation in wound components	No additional insulation used.	N/A
	Working voltage		N/A
	- Basic insulation not under stress		N/A
	- Supplementary, reinforced insulation		N/A
2.10.6	Construction of printed boards	See below.	P



IEC 60950-1/Am1			
Clause	Requirement + Test	Result - Remark	Verdict
2.10.6.1	Uncoated printed boards	(see appended table 2.10.3 and 2.10.4)	P
2.10.6.2	Coated printed boards	No special coating in order to reduce distances.	N/A
2.10.6.3	Insulation between conductors on the same inner surface of a printed board	No such parts.	N/A
2.10.6.4	Insulation between conductors on different layers of a printed board	PCB layout does not serve as insulation barrier.	N/A
	Distance through insulation		N/A
	Number of insulation layers (pcs).....:		N/A
2.10.7	Component external terminations	Coatings not used over terminations to increase effective creepage and clearance distances.	N/A
2.10.8	Tests on coated printed boards and coated components	No special coating in order to reduce distance.	N/A
2.10.8.1	Sample preparation and preliminary inspection		N/A
2.10.8.2	Thermal conditioning		N/A
2.10.8.3	Electric strength test		N/A
2.10.8.4	Abrasion resistance test		N/A
2.10.9	Thermal cycling	No such devices.	N/A
2.10.10	Test for Pollution Degree 1 environment and insulating compound	No such devices.	N/A
2.10.11	Tests for semiconductor devices and cemented joints	No such devices.	N/A
2.10.12	Enclosed and sealed parts	No such devices.	N/A
3	WIRING, CONNECTIONS AND SUPPLY		P
3.1	General		P
3.1.1	Current rating and overcurrent protection	Internal wires are UL recognized wiring which is PVC insulated, rated VW-1. Internal wiring gauge is suitable for current intended to be carried.	P



IEC 60950-1/Am1			
Clause	Requirement + Test	Result - Remark	Verdict
3.1.2	Protection against mechanical damage	Wireways are smooth and free from edges. Wires are adequately fixed to prevent excessive strain on wire and terminals and avoiding damage to the insulation of the conductors.	P
3.1.3	Securing of internal wiring	Internal wiring is secured against excessive strain, loosening of terminals and damage to the conductor insulation.	P
3.1.4	Insulation of conductors	Insulation on internal conductors is considered to be of adequate quality and suitable for the application and the working voltage involved.	P
3.1.5	Beads and ceramic insulators	No beads or similar ceramic insulators on conductors.	N/A
3.1.6	Screws for electrical contact pressure	No screws of insulating material used for electrical connection.	N/A
3.1.7	Insulating materials in electrical connections	No contact pressure through insulating material.	P
3.1.8	Self-tapping and spaced thread screws	No self-tapping or spaced thread screws used.	N/A
3.1.9	Termination of conductors	Terminations cannot become displaced so that clearances and creepage distances can be reduced.	P
	10 N pull test		P
3.1.10	Sleeving on wiring	No sleeving on wire.	N/A
3.2	Connection to a mains supply		N/A
3.2.1	Means of connection	Built-in equipment. Compliance shall be evaluated with the end-product. See summary of testing also.	N/A
3.2.1.1	Connection to an a.c. mains supply		N/A
3.2.1.2	Connection to a d.c. mains supply		N/A
3.2.2	Multiple supply connections		N/A
3.2.3	Permanently connected equipment		N/A



IEC 60950-1/Am1			
Clause	Requirement + Test	Result - Remark	Verdict
	Number of conductors, diameter of cable and conduits (mm)		—
3.2.4	Appliance inlets		N/A
3.2.5	Power supply cords		N/A
3.2.5.1	AC power supply cords		N/A
	Type		—
	Rated current (A), cross-sectional area (mm ²), AWG		—
3.2.5.2	DC power supply cords		N/A
3.2.6	Cord anchorages and strain relief		N/A
	Mass of equipment (kg), pull (N)		—
	Longitudinal displacement (mm)		—
3.2.7	Protection against mechanical damage		N/A
3.2.8	Cord guards		N/A
	Diameter or minor dimension D (mm); test mass (g)		—
	Radius of curvature of cord (mm).....		—
3.2.9	Supply wiring space		N/A
3.3	Wiring terminals for connection of external conductors		N/A
3.3.1	Wiring terminals	Input terminal block provided. Compliance shall evaluated with the end-product.	N/A
3.3.2	Connection of non-detachable power supply cords		N/A
3.3.3	Screw terminals		N/A
3.3.4	Conductor sizes to be connected		N/A
	Rated current (A), cord/cable type, cross-sectional area (mm ²).....		—
3.3.5	Wiring terminal sizes		N/A
	Rated current (A), type, nominal thread diameter (mm)		—
3.3.6	Wiring terminal design		N/A
3.3.7	Grouping of wiring terminals		N/A
3.3.8	Stranded wire		N/A
3.4	Disconnection from the mains supply		N/A



IEC 60950-1/Am1			
Clause	Requirement + Test	Result - Remark	Verdict
3.4.1	General requirement	Built-in equipment. Compliance shall be evaluated with the end-product.	N/A
3.4.2	Disconnect devices		N/A
3.4.3	Permanently connected equipment		N/A
3.4.4	Parts which remain energized		N/A
3.4.5	Switches in flexible cords		N/A
3.4.6	Number of poles - single-phase and d.c. equipment		N/A
3.4.7	Number of poles - three-phase equipment		N/A
3.4.8	Switches as disconnect devices		N/A
3.4.9	Plugs as disconnect devices		N/A
3.4.10	Interconnected equipment		N/A
3.4.11	Multiple power sources		N/A

3.5	Interconnection of equipment		N/A
3.5.1	General requirements	Built-in equipment. Compliance shall be evaluated with the end-product.	N/A
3.5.2	Types of interconnection circuits		N/A
3.5.3	ELV circuits as interconnection circuits		N/A
3.5.4	Data ports for additional equipment		N/A

4	PHYSICAL REQUIREMENTS		P
4.1	Stability		N/A
	Angle of 10°	Built-in equipment. Compliance shall be evaluated with the end-product.	N/A
	Test force (N)		N/A

4.2	Mechanical strength		P
4.2.1	General		P
	Rack-mounted equipment.	Built-in equipment.	N/A
4.2.2	Steady force test, 10 N	No hazards.	P



IEC 60950-1/Am1			
Clause	Requirement + Test	Result - Remark	Verdict
4.2.3	Steady force test, 30 N	Built-in equipment. Compliance shall be evaluated with the end-product.	N/A
4.2.4	Steady force test, 250 N	Built-in equipment. Compliance shall be evaluated with the end-product.	N/A
4.2.5	Impact test	Built-in equipment. Compliance shall be evaluated with the end-product.	N/A
	Fall test		N/A
	Swing test		N/A
4.2.6	Drop test; height (mm)	Built-in equipment. Compliance shall be evaluated with the end-product.	N/A
4.2.7	Stress relief test	Built-in equipment. Compliance shall be evaluated with the end-product.	N/A
4.2.8	Cathode ray tubes	No CRT.	N/A
	Picture tube separately certified		N/A
4.2.9	High pressure lamps	No such lamp.	N/A
4.2.10	Wall or ceiling mounted equipment; force (N)	Built-in equipment..	N/A
	Test to cover on the door.....		N/A

4.3	Design and construction		P
4.3.1	Edges and corners	Edges and corners are rounded and smooth.	P
4.3.2	Handles and manual controls; force (N)	No such parts.	N/A
4.3.3	Adjustable controls	No such controls.	N/A
4.3.4	Securing of parts	No loosening of parts impairing creepage distances or clearances is likely to occur.	P
4.3.5	Connection by plugs and sockets	SELV connectors do not comply with IEC 60320 or IEC 60083.	N/A
4.3.6	Direct plug-in equipment	Not direct plug-in equipment.	N/A
	Torque		—



IEC 60950-1/Am1			
Clause	Requirement + Test	Result - Remark	Verdict
	Compliance with the relevant mains plug standard		N/A
4.3.7	Heating elements in earthed equipment	No such elements.	N/A
4.3.8	Batteries	No battery.	N/A
	- Overcharging of a rechargeable battery		N/A
	- Unintentional charging of a non-rechargeable battery		N/A
	- Reverse charging of a rechargeable battery		N/A
	- Excessive discharging rate for any battery		N/A
4.3.9	Oil and grease	No parts exposed to such substance.	N/A
4.3.10	Dust, powders, liquids and gases	The equipment does not generate dust or powders, and does not contain flammable liquids or gases.	N/A
4.3.11	Containers for liquids or gases	No such containers.	N/A
4.3.12	Flammable liquids	The equipment does not contain flammable liquid.	N/A
	Quantity of liquid (l)		N/A
	Flash point (°C)		N/A
4.3.13	Radiation	Refer below.	N/A
4.3.13.1	General	Refer below.	N/A
4.3.13.2	Ionizing radiation	The equipment does not generate ionizing radiation.	N/A
	Measured radiation (pA/kg)		—
	Measured high-voltage (kV)		—
	Measured focus voltage (kV)		—
	CRT markings		—
4.3.13.3	Effect of ultraviolet (UV) radiation on materials	The equipment does not produce significant UV radiation.	N/A
	Part, property, retention after test, flammability classification		N/A
4.3.13.4	Human exposure to ultraviolet (UV) radiation		N/A
4.3.13.5	Lasers (including laser diodes) and LEDs		N/A
4.3.13.5.1	Lasers (including laser diodes)		N/A
	Laser class		—
4.3.13.5.2	Light emitting diodes (LEDs)		N/A



IEC 60950-1/Am1			
Clause	Requirement + Test	Result - Remark	Verdict
4.3.13.6	Other types		N/A

4.4	Protection against hazardous moving parts		N/A
4.4.1	General	Built-in equipment, compliance shall be evaluated with the end-product.	N/A
4.4.2	Protection in operator access areas		N/A
	Household and home/office document/media shredders		N/A
4.4.3	Protection in restricted access locations		N/A
4.4.4	Protection in service access areas		N/A
4.4.5	Protection against moving fan blades		N/A
4.4.5.1	General		N/A
	Not considered to cause pain or injury. a).....		N/A
	Is considered to cause pain, not injury. b)		N/A
	Considered to cause injury. c)		N/A
4.4.5.2	Protection for users		N/A
	Use of symbol or warning		N/A
4.4.5.3	Protection for service persons		N/A
	Use of symbol or warning		N/A

4.5	Thermal requirements		P
4.5.1	General	Considered.	P
4.5.2	Temperature tests	(see appended table 4.5)	P
	Normal load condition per Annex L	Rated load with continuous operation.	—
4.5.3	Temperature limits for materials	(see appended table 4.5)	P
4.5.4	Touch temperature limits	(see appended table 4.5)	P
4.5.5	Resistance to abnormal heat	(see appended table 4.5.5)	P

4.6	Openings in enclosures		N/A
4.6.1	Top and side openings	Built-in equipment, compliance shall be evaluated with the end-product.	N/A
	Dimensions (mm)		—



IEC 60950-1/Am1			
Clause	Requirement + Test	Result - Remark	Verdict
4.6.2	Bottoms of fire enclosures		N/A
	Construction of the bottom, dimensions (mm) ...:		—
4.6.3	Doors or covers in fire enclosures		N/A
4.6.4	Openings in transportable equipment		N/A
4.6.4.1	Constructional design measures		N/A
	Dimensions (mm):		—
4.6.4.2	Evaluation measures for larger openings		N/A
4.6.4.3	Use of metallized parts		N/A
4.6.5	Adhesives for constructional purposes		N/A
	Conditioning temperature (°C), time (weeks):		—
4.7	Resistance to fire		P
4.7.1	Reducing the risk of ignition and spread of flame	Method 1 is used.	P
	Method 1, selection and application of components wiring and materials	Materials with required flammability class used. See appended table 1.5.1.	P
	Method 2, application of all of simulated fault condition tests		N/A
4.7.2	Conditions for a fire enclosure	Refer below.	P
4.7.2.1	Parts requiring a fire enclosure	The fire enclosure is required to cover all parts.	P
4.7.2.2	Parts not requiring a fire enclosure		N/A
4.7.3	Materials		P
4.7.3.1	General	Components and materials have adequate flammability classification. See appended table 1.5.1.	P
4.7.3.2	Materials for fire enclosures	The fire enclosure is of flame class min. V-1 material. Built-in equipment, compliance of input terminal part shall be evaluated with the end-product.	N/A
4.7.3.3	Materials for components and other parts outside fire enclosures	No components and other parts outside fire enclosure.	N/A
4.7.3.4	Materials for components and other parts inside fire enclosures	Minimum V-2 material used.	P
4.7.3.5	Materials for air filter assemblies	No air filters in the equipment.	N/A



IEC 60950-1/Am1			
Clause	Requirement + Test	Result - Remark	Verdict
4.7.3.6	Materials used in high-voltage components	No high voltage (>4 KV) components.	N/A

5	ELECTRICAL REQUIREMENTS AND SIMULATED ABNORMAL CONDITIONS		P
5.1	Touch current and protective conductor current		N/A
5.1.1	General	Built-in equipment, compliance shall be evaluated with the end-product.	N/A
5.1.2	Configuration of equipment under test (EUT)		N/A
5.1.2.1	Single connection to an a.c. mains supply		N/A
5.1.2.2	Redundant multiple connections to an a.c. mains supply		N/A
5.1.2.3	Simultaneous multiple connections to an a.c. mains supply		N/A
5.1.3	Test circuit		N/A
5.1.4	Application of measuring instrument		N/A
5.1.5	Test procedure		N/A
5.1.6	Test measurements		N/A
	Supply voltage (V)		—
	Measured touch current (mA)		—
	Max. allowed touch current (mA)		—
	Measured protective conductor current (mA)		—
	Max. allowed protective conductor current (mA)		—
5.1.7	Equipment with touch current exceeding 3,5 mA		N/A
5.1.7.1	General		N/A
5.1.7.2	Simultaneous multiple connections to the supply		N/A
5.1.8	Touch currents to telecommunication networks and cable distribution systems and from telecommunication networks		N/A
5.1.8.1	Limitation of the touch current to a telecommunication network or to a cable distribution system		N/A
	Supply voltage (V)		—
	Measured touch current (mA)		—
	Max. allowed touch current (mA)		—
5.1.8.2	Summation of touch currents from telecommunication networks		N/A



IEC 60950-1/Am1			
Clause	Requirement + Test	Result - Remark	Verdict
	a) EUT with earthed telecommunication ports :		N/A
	b) EUT whose telecommunication ports have no reference to protective earth		N/A

5.2	Electric strength		P
5.2.1	General	(see appended table 5.2)	P
5.2.2	Test procedure	(see appended table 5.2)	P

5.3	Abnormal operating and fault conditions		P
5.3.1	Protection against overload and abnormal operation	(see appended table 5.3)	P
5.3.2	Motors	No motor.	N/A
5.3.3	Transformers	See Annex C and appended table C.2.	P
5.3.4	Functional insulation..... :	Complies with a) and c).	P
5.3.5	Electromechanical components	No electromechanical components.	N/A
5.3.6	Audio amplifiers in ITE :	No audio amplifier.	N/A
5.3.7	Simulation of faults	(see appended table 5.3)	P
5.3.8	Unattended equipment	Equipment not intended for unattended use.	N/A
5.3.9	Compliance criteria for abnormal operating and fault conditions	Refer below:	P
5.3.9.1	During the tests	No fire or molten metal occurred and no deformation of enclosure during the tests.	P
5.3.9.2	After the tests	No reduction of clearance and creepage distances. Electric strength test is made on basic, supplementary and reinforced insulation.	P

6	CONNECTION TO TELECOMMUNICATION NETWORKS		N/A
6.1	Protection of telecommunication network service persons, and users of other equipment connected to the network, from hazards in the equipment		N/A
6.1.1	Protection from hazardous voltages		N/A
6.1.2	Separation of the telecommunication network from earth		N/A
6.1.2.1	Requirements	No TNV circuits.	N/A
	Supply voltage (V):		—



IEC 60950-1/Am1			
Clause	Requirement + Test	Result - Remark	Verdict
	Current in the test circuit (mA)		—
6.1.2.2	Exclusions		N/A
6.2	Protection of equipment users from overvoltages on telecommunication networks		N/A
6.2.1	Separation requirements	No TNV circuits.	N/A
6.2.2	Electric strength test procedure		N/A
6.2.2.1	Impulse test		N/A
6.2.2.2	Steady-state test		N/A
6.2.2.3	Compliance criteria		N/A
6.3	Protection of the telecommunication wiring system from overheating		N/A
	Max. output current (A)	No TNV circuits.	—
	Current limiting method		—
7	CONNECTION TO CABLE DISTRIBUTION SYSTEMS		N/A
7.1	General	No cable distribution systems.	N/A
7.2	Protection of cable distribution system service persons, and users of other equipment connected to the system, from hazardous voltages in the equipment		N/A
7.3	Protection of equipment users from overvoltages on the cable distribution system		N/A
7.4	Insulation between primary circuits and cable distribution systems		N/A
7.4.1	General		N/A
7.4.2	Voltage surge test		N/A
7.4.3	Impulse test		N/A
A	ANNEX A, TESTS FOR RESISTANCE TO HEAT AND FIRE		N/A
A.1	Flammability test for fire enclosures of movable equipment having a total mass exceeding 18 kg, and of stationary equipment (see 4.7.3.2)		N/A
A.1.1	Samples.....		—
	Wall thickness (mm)		—
A.1.2	Conditioning of samples; temperature (°C)		N/A



IEC 60950-1/Am1			
Clause	Requirement + Test	Result - Remark	Verdict
A.1.3	Mounting of samples		N/A
A.1.4	Test flame (see IEC 60695-11-3)		N/A
	Flame A, B, C or D		—
A.1.5	Test procedure		N/A
A.1.6	Compliance criteria		N/A
	Sample 1 burning time (s)		—
	Sample 2 burning time (s)		—
	Sample 3 burning time (s)		—
A.2	Flammability test for fire enclosures of movable equipment having a total mass not exceeding 18 kg, and for material and components located inside fire enclosures (see 4.7.3.2 and 4.7.3.4)		N/A
A.2.1	Samples, material		—
	Wall thickness (mm)		—
A.2.2	Conditioning of samples; temperature (°C)		N/A
A.2.3	Mounting of samples		N/A
A.2.4	Test flame (see IEC 60695-11-4)		N/A
	Flame A, B or C		—
A.2.5	Test procedure		N/A
A.2.6	Compliance criteria		N/A
	Sample 1 burning time (s)		—
	Sample 2 burning time (s)		—
	Sample 3 burning time (s)		—
A.2.7	Alternative test acc. to IEC 60695-11-5, cl. 5 and 9		N/A
	Sample 1 burning time (s)		—
	Sample 2 burning time (s)		—
	Sample 3 burning time (s)		—
A.3	Hot flaming oil test (see 4.6.2)		N/A
A.3.1	Mounting of samples		N/A
A.3.2	Test procedure		N/A
A.3.3	Compliance criterion		N/A
B	ANNEX B, MOTOR TESTS UNDER ABNORMAL CONDITIONS(see 4.7.2.2 and 5.3.2)		N/A
B.1	General requirements	No motor.	N/A



IEC 60950-1/Am1			
Clause	Requirement + Test	Result - Remark	Verdict
	Position		—
	Manufacturer		—
	Type		—
	Rated values		—
B.2	Test conditions		N/A
B.3	Maximum temperatures		N/A
B.4	Running overload test		N/A
B.5	Locked-rotor overload test		N/A
	Test duration (days)		—
	Electric strength test: test voltage (V)		—
B.6	Running overload test for d.c. motors in secondary circuits		N/A
B.6.1	General		N/A
B.6.2	Test procedure		N/A
B.6.3	Alternative test procedure		N/A
B.6.4	Electric strength test; test voltage (V)		N/A
B.7	Locked-rotor overload test for d.c. motors in secondary circuits		N/A
B.7.1	General		N/A
B.7.2	Test procedure		N/A
B.7.3	Alternative test procedure		N/A
B.7.4	Electric strength test; test voltage (V)		N/A
B.8	Test for motors with capacitors		N/A
B.9	Test for three-phase motors		N/A
B.10	Test for series motors		N/A
	Operating voltage (V)		—

C	ANNEX C, TRANSFORMERS (see 1.5.4 and 5.3.3)		P
	Position	Input - output.: T1	—
	Manufacturer	(see appended table 1.5.1.)	—
	Type	(see appended table 1.5.1.)	—
	Rated values	(see appended table 1.5.1.)	—
	Method of protection.....	Inherent protection.	—
C.1	Overload test	(see appended table 5.3)	P



IEC 60950-1/Am1			
Clause	Requirement + Test	Result - Remark	Verdict
C.2	Insulation	The insulation fulfils the requirements in 2.10 and relevant test for 5.2.2. (see appended tables 5.2)	P
	Protection from displacement of windings..... :	Secured to the soldering pins with wrapping.	P

D	ANNEX D, MEASURING INSTRUMENTS FOR TOUCH-CURRENT TESTS (see 5.1.4)		N/A
D.1	Measuring instrument		N/A
D.2	Alternative measuring instrument		N/A

E	ANNEX E, TEMPERATURE RISE OF A WINDING (see 1.4.13)		N/A
----------	--	--	-----

F	ANNEX F, MEASUREMENT OF CLEARANCES AND CREEPAGE DISTANCES (see 2.10 and Annex G)		P
----------	---	--	---

G	ANNEX G, ALTERNATIVE METHOD FOR DETERMINING MINIMUM CLEARANCES		N/A
G.1	Clearances		N/A
G.1.1	General		N/A
G.1.2	Summary of the procedure for determining minimum clearances		N/A
G.2	Determination of mains transient voltage (V)		N/A
G.2.1	AC mains supply		N/A
G.2.2	Earthed d.c. mains supplies		N/A
G.2.3	Unearthed d.c. mains supplies		N/A
G.2.4	Battery operation		N/A
G.3	Determination of telecommunication network transient voltage (V)		N/A
G.4	Determination of required withstand voltage (V)		N/A
G.4.1	Mains transients and internal repetitive peaks		N/A
G.4.2	Transients from telecommunication networks		N/A
G.4.3	Combination of transients		N/A
G.4.4	Transients from cable distribution systems		N/A
G.5	Measurement of transient voltages (V)		N/A
	a) Transients from a mains supply		N/A



IEC 60950-1/Am1			
Clause	Requirement + Test	Result - Remark	Verdict
	For an a.c. mains supply		N/A
	For a d.c. mains supply		N/A
	b) Transients from a telecommunication network		N/A
G.6	Determination of minimum clearances		N/A
H	ANNEX H, IONIZING RADIATION (see 4.3.13)		N/A
J	ANNEX J, TABLE OF ELECTROCHEMICAL POTENTIALS (see 2.6.5.6)		P
	Metal(s) used		—
K	ANNEX K, THERMAL CONTROLS (see 1.5.3 and 5.3.8)		N/A
K.1	Making and breaking capacity		N/A
K.2	Thermostat reliability; operating voltage (V)		N/A
K.3	Thermostat endurance test; operating voltage (V)		N/A
K.4	Temperature limiter endurance; operating voltage (V)		N/A
K.5	Thermal cut-out reliability		N/A
K.6	Stability of operation		N/A
L	ANNEX L, NORMAL LOAD CONDITIONS FOR SOME TYPES OF ELECTRICAL BUSINESS EQUIPMENT (see 1.2.2.1 and 4.5.2)		P
L.1	Typewriters		N/A
L.2	Adding machines and cash registers		N/A
L.3	Erasers		N/A
L.4	Pencil sharpeners		N/A
L.5	Duplicators and copy machines		N/A
L.6	Motor-operated files		N/A
L.7	Other business equipment	See operating condition in General Product Information.	P
M	ANNEX M, CRITERIA FOR TELEPHONE RINGING SIGNALS (see 2.3.1)		N/A
M.1	Introduction		N/A
M.2	Method A		N/A
M.3	Method B		N/A



IEC 60950-1/Am1			
Clause	Requirement + Test	Result - Remark	Verdict
M.3.1	Ringing signal		N/A
M.3.1.1	Frequency (Hz)		—
M.3.1.2	Voltage (V)		—
M.3.1.3	Cadence; time (s), voltage (V)		—
M.3.1.4	Single fault current (mA)		—
M.3.2	Tripping device and monitoring voltage		N/A
M.3.2.1	Conditions for use of a tripping device or a monitoring voltage		N/A
M.3.2.2	Tripping device		N/A
M.3.2.3	Monitoring voltage (V)		N/A
N	ANNEX N, IMPULSE TEST GENERATORS (see 1.5.7.2, 1.5.7.3, 2.10.3.9, 6.2.2.1, 7.3.2, 7.4.3 and Clause G.5)		N/A
N.1	ITU-T impulse test generators		N/A
N.2	IEC 60065 impulse test generator		N/A
P	ANNEX P, NORMATIVE REFERENCES		—
Q	ANNEX Q, Voltage dependent resistors (VDRs) (see 1.5.9.1)		P
	a) Preferred climatic categories	Certified VDR used. (see appended table 1.5.1)	P
	b) Maximum continuous voltage	Certified VDR used. (see appended table 1.5.1)	P
	c) Pulse current	Certified VDR used. (see appended table 1.5.1)	P
R	ANNEX R, EXAMPLES OF REQUIREMENTS FOR QUALITY CONTROL PROGRAMMES		N/A
R.1	Minimum separation distances for unpopulated coated printed boards (see 2.10.6.2)		N/A
R.2	Reduced clearances (see 2.10.3)		N/A
S	ANNEX S, PROCEDURE FOR IMPULSE TESTING (see 6.2.2.3)		N/A
S.1	Test equipment		N/A
S.2	Test procedure		N/A
S.3	Examples of waveforms during impulse testing		N/A



IEC 60950-1/Am1			
Clause	Requirement + Test	Result - Remark	Verdict
T	ANNEX T, GUIDANCE ON PROTECTION AGAINST INGRESS OF WATER (see 1.1.2)		P
		The equipment excluding input connector and output connector complied with IP21. IP X0 is for this equipment.	—
U	ANNEX U, INSULATED WINDING WIRES FOR USE WITHOUT INTERLEAVED INSULATION (see 2.10.5.4)		P
		The TIW of T1 was certified. (see appended table 1.5.1)	—
V	ANNEX V, AC POWER DISTRIBUTION SYSTEMS (see 1.6.1)		N/A
V.1	Introduction	Equipment not directly connected to AC mains supply.	N/A
V.2	TN power distribution systems		N/A
W	ANNEX W, SUMMATION OF TOUCH CURRENTS		N/A
W.1	Touch current from electronic circuits		N/A
W.1.1	Floating circuits		N/A
W.1.2	Earthed circuits		N/A
W.2	Interconnection of several equipments		N/A
W.2.1	Isolation		N/A
W.2.2	Common return, isolated from earth		N/A
W.2.3	Common return, connected to protective earth		N/A
X	ANNEX X, MAXIMUM HEATING EFFECT IN TRANSFORMER TESTS (see clause C.1)		P
X.1	Determination of maximum input current		P
X.2	Overload test procedure		P
Y	ANNEX Y, ULTRAVIOLET LIGHT CONDITIONING TEST (see 4.3.13.3)		N/A
Y.1	Test apparatus		N/A
Y.2	Mounting of test samples		N/A
Y.3	Carbon-arc light-exposure apparatus		N/A



IEC 60950-1/Am1			
Clause	Requirement + Test	Result - Remark	Verdict
Y.4	Xenon-arc light exposure apparatus		N/A
Z	ANNEX Z, OVERVOLTAGE CATEGORIES (see 2.10.3.2 and Clause G.2)		N/A
AA	ANNEX AA, MANDREL TEST (see 2.10.5.8)		N/A
BB	ANNEX BB, CHANGES IN THE SECOND EDITION		—
CC	ANNEX CC, Evaluation of integrated circuit (IC) current limiters		N/A
CC.1	General		N/A
CC.2	Test program 1.....		N/A
CC.3	Test program 2.....		N/A
DD	ANNEX DD, Requirements for the mounting means of rack-mounted equipment		N/A
DD.1	General		N/A
DD.2	Mechanical strength test, variable N.....		N/A
DD.3	Mechanical strength test, 250N, including end stops.....		N/A
DD.4	Compliance.....		N/A
EE	ANNEX EE, Household and home/office document/media shredders		N/A
EE.1	General		N/A
EE.2	Markings and instructions		N/A
	Use of markings or symbols.....		N/A
	Information of user instructions, maintenance and/or servicing instructions.....		N/A
EE.3	Inadvertent reactivation test.....		N/A
EE.4	Disconnection of power to hazardous moving parts:		N/A
	Use of markings or symbols.....		N/A
EE.5	Protection against hazardous moving parts		N/A
	Test with test finger (Figure 2A)		N/A
	Test with wedge probe (Figure EE1 and EE2)		N/A



IEC 60950-1/Am1			
Clause	Requirement + Test	Result - Remark	Verdict

1.5.1	TABLE: List of critical components					P
Object/part No.	Manufacturer/ trademark	Type/model	Technical data	Standard (Edition / year)	Mark(s) of conformity ¹⁾	
Enclosure	SABIC	SE100, SE100X, SE1, SE1X, HF500R CX7211 C2950 EXCY0098	Min. 2.0mm thick, flame class V-1 or better	UL 94	UL	
Alternative	TEIJIN	LN-1250P LN-1250G	Min. 2.0mm thick, flame class V-0 or better	UL 94	UL	
Alternative	CHI MEI Corporation	PC-540 PA-765A	Min. 2.0mm thick, flame class V-0 or better	UL 94	UL	
PCB material	Various	Various	Min. V-1, Min.130 °C	UL 94	UL	
Fuse (F1)	Bel	RST	T2A, 250V	IEC/EN 60127-1 IEC/EN 60127-2	VDE	
Alternative	Walter	ICP	T2A, 250V	IEC/EN 60127-1 IEC/EN 60127-2	VDE	
Alternative	Conquer	MST MET	T2A, 250V	IEC/EN 60127-1 IEC/EN 60127-2	VDE	
Alternative	Ever Island	2010	T2A, 250V	IEC/EN 60127-1 IEC/EN 60127-2	VDE	
Alternative	Das & Sons	385T	T2A, 250V	IEC/EN 60127-1 IEC/EN 60127-2	VDE	
Alternative	Cooper Bussmann	SS-5	T2A, 250V	IEC/EN 60127-1 IEC/EN 60127-2	VDE	
Alternative	Save Fusetech	SS-5	T2A, 250V	UL248	UL	
Alternative	Zhongshan Lanbao Electrical	RTI-10	T2A, 250V	IEC/EN 60127-1 IEC/EN 60127-2	VDE	
Alternative	Sunny East	CFD	T2A, 250V	IEC/EN 60127-1 IEC/EN 60127-2	VDE	
Alternative	Lanson	SMT	T2A, 250V	IEC/EN 60127-1 IEC/EN 60127-2	VDE	
Varistor, (MOV) (optional)	TKS	TVR10680 TVR14680	Min.40Vac	IEC/EN 61051-2 2) UL 1449 3)	VDE ,UL	



IEC 60950-1/Am1					
Clause	Requirement + Test		Result - Remark		Verdict
Object/part No.	Manufacturer/ trademark	Type/model	Technical data	Standard (Edition / year)	Mark(s) of conformity ¹⁾
Alternative	Centra	CNR10D680K CNR10D680K	Min.40Vac	IEC/EN 61051-2 2) UL 1449 3)	VDE ,UL
Alternative	JOYIN	10N680K 14N680K	Min.40Vac	IEC/EN 61051-2 2) UL 1449 3)	VDE ,UL
Alternative	Success Electronics Co Ltd	SVR10D680K SVR14D680K	Min.40Vac	IEC/EN 61051-2 2) UL 1449 3)	VDE ,UL
Alternative	Walsin	VZ14D680K	Min.40Vac	IEC/EN 61051-2 2) UL 1449 3)	VDE ,UL
Alternative	Lien Shun Electronics Co., Ltd.	14D680K	Min.40Vac	IEC/EN 61051-2 2) UL 1449 3)	VDE ,UL
Alternative	CERAMATE	GNR10D680K GNR14D680K	Min.40Vac	IEC/EN 61051-2 2) UL 1449 3)	VDE ,UL
Alternative	Brightking	680KD10 680KD14	Min.40Vac	IEC/EN 61051-2 2) UL 1449 3)	VDE ,UL
Alternative	GUANGXI NEW FUTURE	10D680K 14D680K	Min.40Vac	IEC/EN 61051-2 2) UL 1449 3)	VDE ,UL
Line choke (LF1), optional 4)	Globtek/ BOAM/HEJIA/ ZHONGTONG	GT-93020-LF1	130°C	IEC/EN 60950-1	Tested in appliance
Bulk Capacitor (C1)	Various	Various	Max 680µF Min 63V 105°C	IEC/EN 60950-1	Tested in appliance
Bleeder Resistors R1	Various	Various	Max 330K	IEC/EN 60950-1	Tested in appliance
X Capacitor (CX1)	Winday	MPX	AC 275V min., 0.22µF max. 100°C, Min X2	IEC/EN 60384-14 2nd edition	VDE
Alternative	U.T.X.	HQX	AC 275V min., 0.22µF max. 100°C, Min X2	IEC/EN 60384-14 2nd edition	VDE
Alternative	CT	CTX	AC 275V min., 0.22µF max. 100°C, Min X2	IEC/EN 60384-14 2nd edition	VDE
Alternative	DAIN	MPX, NPX	AC 275V min., 0.22µF max. 100°C, Min X2	IEC/EN 60384-14 2nd edition	VDE
Alternative	VISHAY	F 1772	AC 275V min., 0.22µF max. 100°C, Min X2	IEC/EN 60384-14 2nd edition	VDE



IEC 60950-1/Am1					
Clause	Requirement + Test			Result - Remark	Verdict
Object/part No.	Manufacturer/ trademark	Type/model	Technical data	Standard (Edition / year)	Mark(s) of conformity ¹⁾
Alternative	TenTa	MEX	AC 275V min., 0.22µF max. 100°C, Min X2	IEC/EN 60384-14 2nd edition	VDE
Alternative	Okaya	RE	AC 275V min., 0.22µF max. 100°C, Min X2	IEC/EN 60384-14 2nd edition	VDE
Alternative	Da hua	HD	AC 275V min., 0.22µF max. 100°C, Min X2	IEC/EN 60384-14 2nd edition	VDE
Alternative	Welson	WD	AC 275V min., 0.22µF max. 100°C, Min X2	IEC/EN 60384-14 2nd edition	VDE
Alternative	YUON YU	MPX	AC 275V min., 0.22µF max. 100°C, Min X2	IEC/EN 60384-14 2nd edition	VDE
Alternative	SHUNDE CHUANG GE	MKP-X2	AC 275V min., 0.22µF max. 100°C, Min X2	IEC/EN 60384-14 2nd edition	VDE
Alternative	Sinhua Electronics (Huzhou) Co., Ltd	MPX	AC 275V min., 0.22µF max. 100°C, Min X2	IEC/EN 60384-14 2nd edition	VDE
Alternative	Shantou High- New Technology	MPX	AC 275V min., 0.22µF max. 100°C, Min X2	IEC/EN 60384-14 2nd edition	VDE
Alternative	Jiangsu Xinhua Huayu Electronics Co., Ltd.	MPX	AC 275V min., 0.22µF max. 100°C, Min X2	IEC/EN 60384-14 2nd edition	VDE
Alternative	Hongzhi Enterprises Ltd	MPX	AC 275V min., 0.22µF max. 100°C, Min X2	IEC/EN 60384-14 2nd edition	VDE
Bridging capacitor (CY1)	Murata	KX	Min. AC 250V, Max. 2200pF Y1 125 °C	IEC/EN 60384-14 2nd edition UL 1414	VDE, UL
Alternative	WALSIN	AH	Min. AC 250V, Max. 2200pF Y1 125 °C	IEC/EN 60384-14 2nd edition UL 1414	VDE, UL
Alternative	Success	SB SE	Min. AC 250V, Max. 2200pF Y1 125 °C	IEC/EN 60384-14 2nd edition UL 1414	VDE, UL



IEC 60950-1/Am1					
Clause	Requirement + Test			Result - Remark	Verdict
Object/part No.	Manufacturer/ trademark	Type/model	Technical data	Standard (Edition / year)	Mark(s) of conformity ¹⁾
Alternative	TDK	CD	Min. AC 250V, Max. 2200pF Y1 125 °C	IEC/EN 60384-14 2nd edition UL 1414	VDE, UL
Alternative	Welson	WD	Min. AC 250V, Max. 2200pF Y1 125 °C	IEC/EN 60384-14 2nd edition UL 1414	VDE, UL
Alternative	JYA-NAY Co., Ltd.	JN	Min. AC 250V, Max. 2200pF Y1 125 °C	IEC/EN 60384-14 2nd edition UL 1414	VDE, UL
Alternative	Haohua Electronic Co.	CT7	Min. AC 250V, Max. 2200pF Y1 125 °C	IEC/EN 60384-14 2nd edition UL 1414	VDE, UL
Alternative	JERRO ELECTRONICS CORP	JX	Min. AC 250V, Max. 2200pF Y1 125 °C	IEC/EN 60384-14 2nd edition UL 1414	VDE, UL
Alternative	HONGZHI	Y	Min. AC 250V, Max. 2200pF Y1 125 °C	IEC/EN 60384-14 2nd edition UL 1414	VDE, UL
Diode Bridge (D1, D2, D3, D4)	Various	Various	Min.2A Min. 100V	IEC/EN 60950-1	Tested in appliance
Opto-coupler (U1)	Lite-On Technology Corporation	LTV-817 LTV-817M LTV-817S	See appendix opto elec. Min 100°C	EN 60747-5-2 IEC/EN 60950-1	VDE
Alternative	Everlight Electronics Co., Ltd.	EL817	See appendix opto elec. Min 100°C	EN 60747-5-2 IEC/EN 60950-1	VDE
Alternative	Bright LED	BPC817 BPC817M BPC817S	See appendix opto elec. Min 100°C	EN 60747-5-2 IEC/EN 60950-1	VDE
Alternative	Fairchild	H11A817B	See appendix opto elec. Min 100°C	EN 60747-5-2 IEC/EN 60950-1	VDE



IEC 60950-1/Am1					
Clause	Requirement + Test			Result - Remark	Verdict
Object/part No.	Manufacturer/ trademark	Type/model	Technical data	Standard (Edition / year)	Mark(s) of conformity ¹⁾
Alternative	Sharp	PC817 PC817U PC123 PC1231	See appendix opto elec. Min 100°C	EN 60747-5-2 IEC/EN 60950-1	VDE
Alternative	Cosmo	K1010 KP1010	See appendix opto elec. Min 100°C	EN 60747-5-2 IEC/EN 60950-1	VDE
Transformer (T1) 4)	GlobTek/Boam ZhongTong/Hejia	GT-0324001	Class B	IEC/EN 60950-1 IEC/EN 60085	Tested in appliance
Triple winding	Great Leoflon	TRW-B	130°C	UL 2353 IEC/EN 60950-1	UL, VDE
Alternative	Furukawa	TEX-E	130°C	UL 2353 IEC/EN 60950-1	UL, VDE, TUV
Alternative	Totoku	TIW-E	155°C	UL 2353 IEC/EN 60950-1	UL, TUV
Alternative	Cosmolink	TIW-M	155°C	UL 2353 IEC/EN 60950-1	UL, TUV
Insulation tape(for transformer)	3M	1350F-1 1350T-1 44	130°C	UL 510	UL
Alternative	YAHUA	PZ , CT	130°C	UL 510	UL
Alternative	JINGJIANG JINGYI	JY25-A	130°C	UL 510	UL
Alternative	SYMBIO INC	35660	130°C	UL 510	UL
Alternative	Bondtec Pacific	370S	130°C	UL 510	UL
Alternative	Liang Yi	LY-XX	130°C	UL 510	UL
Transistor (Q1)	Various	Various	Min 32A Min.200V	IEC 60950-1	Test in equipment
Supplementary information:					
<ol style="list-style-type: none"> 1) Provided evidence ensures the agreed level of compliance. See OD-CB2039. 2) Varistor was tested additionally with IEC 60950-1:2005 (Annex Q) during the approval to IEC 61051-2. 3) Varistor is for SPD Type 3 SPD application. 4) T1 /LF1 share the same construction from different vendors. 					



IEC 60950-1/Am1			
Clause	Requirement + Test	Result - Remark	Verdict

1.5.1	TABLE: Opto Electronic Devices	P
Manufacturer	Lite-On./ Everlight / Bright / Fairchild/ Sharp / Cosmo / Toshiba	
Type	LTV-817, LTV-817M, LTV-817S / EL817/ BPC817, BPC817M, BPC817S / H11A817B / PC817, PC817U, PC123, PC1231 / K1010, KP1010	
Separately tested	VDE	
Bridging insulation	Reinforced insulation	
External creepage distance	7mm,7mm,7mm / 7mm / 7mm, 7mm, 7mm /7mm / 7mm, 7mm, 7mm / 7mm, 7mm	
Internal creepage distance	5.2mm, 5.2mm, 5.2mm / 5.2mm / 5.2mm, 5.2mm, 5.2mm /5.2mm / 5.2mm, 5.2 mm, 5.2mm, 5.2mm / 5.3mm, 5.3mm	
Distance through insulation	>=0.4mm, >=0.4mm, >=0.4mm / >=0.4mm / >=1.0mm, >=1.0mm, >=1.0mm / >=1.0mm / >=0.4mm, >=0.4mm, >=0.4mm, >=0.4mm / >=0.5mm, >=0.5mm	
Tested under the following conditions	Reinforced insulation	
Input		
Output		
supplementary information		



IEC 60950-1/Am1			
Clause	Requirement + Test	Result - Remark	Verdict

1.6.2	TABLE: Electrical data (in normal conditions)						P
U (V)	I (A)	I rated (A)	P (W)	Fuse #	I fuse (A)	Condition/status	
16/50Hz	0.461	--	5.15	F1	0.461	Output:24V/0.125A	
16/60Hz	0.495	--	5.19	F1	0.495	Output:24V/0.125A	
24/50Hz	0.316	2.0	5.17	F1	0.316	Output:24V/0.125A	
24/60Hz	0.359	2.0	5.22	F1	0.359	Output:24V/0.125A	
34/50Hz	0.239	--	5.26	F1	0.239	Output:24V/0.125A	
34/60Hz	0.277	--	5.28	F1	0.277	Output:24V/0.125A	
Supplementary information:							

2.1.1.5 c) 1)	TABLE: max. V, A, VA test					P
Voltage (rated) (V)	Current (rated) (A)	Voltage (max.) (V)	Current (max.) (A)	VA (max.) (VA)		
24	0.125	24.37	0.818	19.935		
supplementary information:						
The above measurements are the maximum values (max. V and max. A not obtained at the same time).						

2.1.1.5 c) 2)	TABLE: stored energy			N/A
Capacitance C (μ F)	Voltage U (V)		Energy E (J)	
supplementary information:				

2.1.1.7	TABLE: discharge test			P
Condition	τ calculated (s)	τ measured (s)	Comments	
No load	0.0726	0.0624	Vp=49.6V, 37%Vp=18.4V	
supplementary information:				
Overall capacity: 0.22 μ F;				
Discharge resistor: 0.33M Ω				



IEC 60950-1/Am1			
Clause	Requirement + Test	Result - Remark	Verdict
2.2	TABLE: evaluation of voltage limiting components in SELV circuits		P
Component (measured between)	max. voltage (V) (normal operation)		Voltage Limiting Components
	V peak	V d.c.	
T1 output pins	63	--	--
T1 output pins after D7	--	24	D8
Fault test performed on voltage limiting components	Voltage measured (V) in SELV circuits (V peak or V d.c.)		
D7 short-circuit	0.3Vdc, unit shut down.		
supplementary information:			

2.4.2	TABLE: Limited current circuit measurement					P
Location	Voltage (V)	Current (mA)	Freq. (kHz)	Limit (mA)	Comments	
CY1	13.8	6.9	64.1	44.9		
supplementary information:						
Supplied with 34V/60Hz.						

2.5	TABLE: Limited power sources				P
Circuit output tested: Output					
Note: Measured Uoc (V) with all load circuits disconnected: 24.57Vdc					
Components Sample No. Uoc (V)	I _{sc} (A)		VA		
	Meas.	Limit	Meas.	Limit	
Output	0.792	8.0	19.4	100	
ZD1 (Oc)	0.777	8.0	19.0	100	
U3 (pin K-G, Sc) 1)	0	8.0	0	100	
U3 (pin A-G, Sc) 1)	0	8.0	0	100	
U3 (pin A-K, Sc) 1)	0	8.0	0	100	
supplementary information:					
Sc=Short circuit, Oc=Open circuit					
1) Unit shut down.					



IEC 60950-1/Am1			
Clause	Requirement + Test	Result - Remark	Verdict
2.10.2	Table: working voltage measurement		P
Location	RMS voltage (V)	Peak voltage (V)	Comments
CY1 pri.pin to sec. pin	20.1	33.6	
T1 pin 1- pin 3	20.2	35.8	
T1 pin 1- pin 4	26.1	96.0	
T1 pin 2- pin 3	20.2	34.2	
T1 pin 2- pin 4	25.4	94.0	
T1 pin 5- pin 3	21.6	62.8	
T1 pin 5- pin 4	22.0	63.0	
T1 pin 6- pin 3	21.7	64.8	
T1 pin 6- pin 4	21.4	63.5	
U1 pin 1- pin3	40.1	56.6	
U1 pin 1- pin4	37.1	53.2	
U1 pin 2- pin 3	38.9	55.4	
U1 pin 2- pin 4	36.3	52.4	
supplementary information:			
Highest working voltage is in bold.			

2.10.3 and 2.10.4	TABLE: Clearance and creepage distance measurements						P
Clearance (cl) and creepage distance (cr) at/of/between:	U peak (V)	U r.m.s. (V)	Required cl (mm)	cl (mm)	Required cr (mm)	cr (mm)	
Functional:							
L/N before fuse	34	24	1.5	2.6	1.5 *	2.6	
Fuse pin 1-pin 2	34	24	1.5	2.6	1.5 *	2.6	
Basic/ Supplementary:							
T1 core to secondary pin	96.0	40.1	2.0	2.3	2.0 *	2.3	



IEC 60950-1/Am1						
Clause	Requirement + Test			Result - Remark		Verdict
Double/Reinforced:						
T1 pri pin to sec. pin	96.0	40.1	4.0	7.8	4.0 *	7.8
U1 pri pin to sec. pin	96.0	40.1	4.0	7.6	4.0 *	7.6
CY1 pri pin to sec. pin	96.0	40.1	4.0	8.6	4.0 *	8.6
T1 copper sheet to D7	96.0	40.1	4.0	6.8	4.0 *	6.8
T1 copper sheet to C3	96.0	40.1	4.0	8.8	4.0 *	8.8
T1 copper sheet to secondary pin	96.0	40.1	4.0	4.5	4.0 *	4.5
Supplementary information:						
1) T1 copper sheet is primary and enclosed by two layers of insulation tapes as supplementary insulation to separate from components around of secondary circuit. 2) The outside of T1 is enclosed by two layers of insulation tapes to separate from components around of secondary circuit. 3) The inside of T1 is enclosed by three layers of insulation tapes to separate from cooper foil and core. 4) The core of T1 is enclosed by two layers of insulation tapes to separate from primary pin and secondary pin. 5) C3, D7, CY1, C1,R12, MOV and Fuse are fixed by glue. *) Minimum clearance applied as the minimum creepage distance.						

2.10.5	TABLE: Distance through insulation measurements					P
Distance through insulation (DTI) at/of:	U peak (V)	U rms (V)	Test voltage (V)	Required DTI (mm)	DTI (mm)	
Optocoupler (reinforced insulation)	56.6	40.1	AC 1025V	≥0.4	Approved comp.1)	
Enclosure	96.0	40.1	AC 1319V	≥0.4	2.0	
Supplementary information:						
1) Optocoupler are approved components.						



IEC 60950-1/Am1									
Clause	Requirement + Test							Result - Remark	Verdict
4.3.8	TABLE: Batteries								N/A
The tests of 4.3.8 are applicable only when appropriate battery data is not available									
Is it possible to install the battery in a reverse polarity position?									
	Non-rechargeable batteries			Rechargeable batteries					
	Discharging		Un-intentional charging	Charging		Discharging		Reversed charging	
	Meas. current	Manuf. Specs.		Meas. current	Manuf. Specs.	Meas. current	Manuf. Specs.	Meas. current	Manuf. Specs.
Max. current during normal condition									
Max. current during fault condition									
Test results:								Verdict	
- Chemical leaks									
- Explosion of the battery									
- Emission of flame or expulsion of molten metal									
- Electric strength tests of equipment after completion of tests									
Supplementary information:									

4.3.8	TABLE: Batteries	N/A
Battery category.....: (Lithium, NiMh, NiCad, Lithium Ion ...)		
Manufacturer.....:		
Type / model.....:		
Voltage.....:		
Capacity.....: mAh		
Tested and Certified by (incl. Ref. No.).....:		
Circuit protection diagram:		



IEC 60950-1/Am1			
Clause	Requirement + Test	Result - Remark	Verdict

--

MARKINGS AND INSTRUCTIONS (1.7.13)	
Location of replaceable battery	
Language(s)	
Close to the battery	
In the servicing instructions	
In the operating instructions	



IEC 60950-1/Am1								
Clause	Requirement + Test	Result - Remark				Verdict		
4.5	TABLE: Thermal requirements					P		
	Supply voltage (V)	16Vac 50Hz	16Vac 60Hz	34Vac 50Hz	34Vac 60Hz	—		
	Ambient T _{min} (°C)	65	65	65	65	—		
	Ambient T _{max} (°C)	65	65	65	65	—		
Maximum measured temperature T of part/at::		T (°C)				Allowed T _{max} (°C)		
Enclosure outside		84.8	84.9	83.8	85.2	—	95	
Enclosure inside		89.2	89.3	87.4	89.7	—	—	
CN1		83.3	83.3	78.3	81.1	—	95	
LF1 winding		84.3	84.4	78.7	81.5	—	130	
Capacitor CX1		88.3	88.4	82.9	86.3	—	100	
PCB near D2		93.9	93.9	87.4	90.4	—	130	
Capacitor C1		93.7	93.7	88.9	91.8	—	105	
PCB near Q1		106.2	106.3	103.7	106.3	—	130	
Capacitor CY1		95.7	95.9	94.0	96.2	—	125	
T1 copper sheet		96.5	96.8	95.8	97.5	—	110*	
PCB near T1		97.7	98.0	96.8	99.0	—	130	
Opto-coupler U1		94.0	94.2	92.8	94.7	—	100	
Capacitor C3		83.4	93.6	93.1	94.8	—	105	
Output connector		65.8	65.8	65.9	66.0	—	95	
Supplementary information:								
Temperature T of winding:		t ₁ (°C)	R ₁ (Ω)	t ₂ (°C)	R ₂ (Ω)	T (°C)	Allowed T _{max} (°C)	Insulation class
—		—	—	—	—	—	—	—
Supplementary information:								
*): The temperature of winding is determined by thermocouple. Temperature limit is decreased 10°C. T _{ma} =65°C								



IEC 60950-1/Am1			
Clause	Requirement + Test	Result - Remark	Verdict

4.5.5	TABLE: Ball pressure test of thermoplastic parts		P
	Allowed impression diameter (mm)	≤ 2 mm	—
Part	Test temperature (°C)	Impression diameter (mm)	
Input connector CN1	100	1.1	
Supplementary information:			

4.7	TABLE: Resistance to fire					P
Part	Manufacturer of material	Type of material	Thickness (mm)	Flammability class	Evidence	
Enclosure	See table 1.5.1	See table 1.5.1	2.0	V-1	See table 1.5.1	
Supplementary information:						

5.1	TABLE: touch current measurement			N/A
Measured between:	Measured (mA)	Limit (mA)	Comments/conditions	
supplementary information:				

5.2	TABLE: Electric strength tests, impulse tests and voltage surge tests			P
Test voltage applied between:	Voltage shape (AC, DC, impulse, surge)	Test voltage (V)	Breakdown Yes / No	
Basic/supplementary:				
T1 primary and core	AC	825	No	
T1 secondary and core	AC	825	No	
Reinforced:				
Input and output	AC	1319	No	
Input and accessible parts/enclosure(unearthed)	AC	1319	No	
T1 primary and secondary	AC	1319	No	
Insulation tape used in T1(Tested with 1 layer)	AC	1319	No	
Supplementary information:				
Test for all types transformers of all manufacturers.				



IEC 60950-1/Am1			
Clause	Requirement + Test	Result - Remark	Verdict

5.3	TABLE: Fault condition tests					P
	Ambient temperature (°C)				65°C if not specified	—
	Power source for EUT: Manufacturer, model/type, output rating				--	—
Component No.	Fault	Supply voltage (V)	Test time	Fuse #	Fuse current (A)	Observation
U1 pin1-2	s-c	34	<1s	F1	1)	Fuse opened in 1 s, no hazards occurred.
U1 pin3-4	s-c	34	5min	F1	0.01	Unit shut down, no hazards occurred.
Q1 (D-G)	s-c	34	<1s	F1	1)	Fuse opened in 1 s, no hazards occurred.
Q1 (S-G)	s-c	34	5min	F1	0	Unit shut down, no hazards occurred.
Q1 (D-S)	s-c	34	<1s	F1	1)	Fuse opened in 1 s, no hazards occurred.
U2 pin1-5	s-c	34	5min	F1	0.01	Unit shut down, no hazards occurred.
R12	s-c	34	5min	F1	0.28	Normal operation.
D1	s-c	34	<1s	F1	1)	Fuse opened in 1 s, no hazards occurred.
C1	s-c	34	<1s	F1	1)	Fuse opened in 1 s, no hazards occurred.
C3	s-c	34	5min	F1	0.23	Unit shut down, no hazards occurred.
T1 pin3-4	s-c	34	2h	F1	0.67	Normal operation. T1 max:145.3°C.
Output	s-c	34	5min	F1	0.09	Unit shut down, no hazards occurred.
Output	o-l	34	2h	F1	0.32	Output overloaded to 0.62A, T1: 153.0°C stable.
Supplementary information:						
1) Fuse current > fuse rating of which opened under test x 2.1 and repeated with all other sources with same result.						
2) o-l:overload ,s-c:short circuit						



IEC 60950-1/Am1

Clause	Requirement + Test	Result - Remark	Verdict
--------	--------------------	-----------------	---------

C.2	TABLE: transformers							P
Loc.	Tested insulation		Working voltage peak / V (2.10.2)	Working voltage rms / V (2.10.2)	Required electric strength (5.2)	Required clearance / mm (2.10.3)	Required creepage distance / mm (2.10.4)	Required distance thr. insul. (2.10.5)
T1	Basic		96.0	26.1	AC 825V	2.0	2.0 2)	—
T1	Supplementary		96.0	26.1	AC 825V	2.0	2.0 2)	2 layers
T1	Reinforced: Primary to secondary		96.0	26.1	AC 1319V	4.0	4.0 2)	1)
Loc.	Tested insulation				Test voltage/ V	Measured clearance / mm	Measured creepage dist./ mm	Measured distance thr. insul. / mm; number of layers
T1 3)	Basic: T1 secondary pin - core				AC 825V	2.3	2.3	—
T1 3)	Supplementary: core – T1 primary pin				AC 825V	4.5	4.5	2 layers
T1	Reinforced: Primary to secondary				AC 1319V	7.6	7.6	TIW
supplementary information:								
1) 2 or 3 layers / 0.4mm / Annex U;								
2) Minimum clearance applied as the minimum creepage distance.								
3) Comply with primary-core-secondary.								

IEC 60950-1			
Clause	Requirement + Test	Result - Remark	Verdict

ATTACHMENT TO TEST REPORT IEC 60950-1 EUROPEAN GROUP DIFFERENCES AND NATIONAL DIFFERENCES Information technology equipment – Safety – Part 1: General requirements			
Differences according to:		EN 60950-1:2006/A11:2009/A1:2010/A12:2011	
Attachment Form No.:		EU_GD_IEC60950_1C_II	
Attachment Originator:		SGS Fimko Ltd	
Master Attachment:		Date 2011-08	
Copyright © 2011 IEC System for Conformity Testing and Certification of Electrical Equipment (IECEE), Geneva, Switzerland. All rights reserved.			

EN 60950-1:2006/A11:2009/A1:2010/A12:2011 – CENELEC COMMON MODIFICATIONS

IEC 60950-1, GROUP DIFFERENCES (CENELEC common modifications EN)			
Clause	Requirement + Test	Result - Remark	Verdict
Contents	Add the following annexes: Annex ZA (normative) Normative references to international publications with their corresponding European publications Annex ZB (normative) Special national conditions		P
General	Delete all the “country” notes in the reference document (IEC 60950-1:2005) according to the following list: 1.4.8 Note 2 1.5.1 Note 2 & 3 1.5.7.1 Note 1.5.8 Note 2 1.5.9.4 Note 1.7.2.1 Note 4, 5 & 6 2.2.3 Note 2.2.4 Note 2.3.2 Note 2.3.2.1 Note 2 2.3.4 Note 2 2.6.3.3 Note 2 & 3 2.7.1 Note 2.10.3.2 Note 2 2.10.5.13 Note 3 3.2.1.1 Note 3.2.4 Note 3. 2.5.1 Note 2 4.3.6 Note 1 & 2 4.7 Note 4 4.7.2.2 Note 4.7.3.1 Note 2 5.1.7.1 Note 3 & 4 5.3.7 Note 1 6 Note 2 & 5 6.1.2.1 Note 2 6.1.2.2 Note 6.2.2 Note 6.2.2.1 Note 2 6.2.2.2 Note 7.1 Note 3 7.2 Note 7.3 Note 1 & 2 G.2.1 Note 2 Annex H Note 2		P
General (A1:2010)	Delete all the “country” notes in the reference document (IEC 60950-1:2005/A1:2010) according to the following list: 1.5.7.1 Note 6.1.2.1 Note 2 6.2.2.1 Note 2 EE.3 Note		P

IEC 60950-1			
Clause	Requirement + Test	Result - Remark	Verdict
IEC 60950-1, GROUP DIFFERENCES (CENELEC common modifications EN)			
Clause	Requirement + Test	Result - Remark	Verdict
1.3.Z1	<p>Add the following subclause:</p> <p>1.3.Z1 Exposure to excessive sound pressure</p> <p>The apparatus shall be so designed and constructed as to present no danger when used for its intended purpose, either in normal operating conditions or under fault conditions, particularly providing protection against exposure to excessive sound pressures from headphones or earphones.</p> <p>NOTE Z1 A new method of measurement is described in EN 50332-1, Sound system equipment: Headphones and earphones associated with portable audio equipment - Maximum sound pressure level measurement methodology and limit considerations - Part 1: General method for "one package equipment", and in EN 50332-2, Sound system equipment: Headphones and earphones associated with portable audio equipment - Maximum sound pressure level measurement methodology and limit considerations - Part 2: Guidelines to associate sets with headphones coming from different manufacturers.</p>	This equipment is not portable audio equipment.	N/A
(A12:2011)	<p>In EN 60950-1:2006/A12:2011</p> <p>Delete the addition of 1.3.Z1 / EN 60950-1:2006</p> <p>Delete the definition 1.2.3.Z1 / EN 60950-1:2006 /A1:2010</p>	Considered.	N/A
1.5.1	<p>Add the following NOTE:</p> <p>NOTE Z1 The use of certain substances in electrical and electronic equipment is restricted within the EU: see Directive 2002/95/EC</p>	Considered.	P
1.7.2.1 (A1:2010)	In addition, for a PORTABLE SOUND SYSTEM, the instructions shall include a warning that excessive sound pressure from earphones and headphones can cause hearing loss.		N/A
1.7.2.1 (A12:2011)	<p>In EN 60950-1:2006/A12:2011</p> <p>Delete NOTE Z1 and the addition for Portable Sound System.</p> <p>Add the following clause and annex to the existing standard and amendments.</p>	This equipment is not personal music player.	N/A
	Zx Protection against excessive sound pressure from personal music players		

IEC 60950-1			
Clause	Requirement + Test	Result - Remark	Verdict
IEC 60950-1, GROUP DIFFERENCES (CENELEC common modifications EN)			
Clause	Requirement + Test	Result - Remark	Verdict
	<p>Zx.1 General</p> <p>This sub-clause specifies requirements for protection against excessive sound pressure from personal music players that are closely coupled to the ear. It also specifies requirements for earphones and headphones intended for use with personal music players.</p> <p>A personal music player is a portable equipment for personal use, that:</p> <ul style="list-style-type: none"> – is designed to allow the user to listen to recorded or broadcast sound or video; and – primarily uses headphones or earphones that can be worn in or on or around the ears; and – allows the user to walk around while in use. <p>NOTE 1 Examples are hand-held or body-worn portable CD players, MP3 audio players, mobile phones with MP3 type features, PDA's or similar equipment.</p> <p>A personal music player and earphones or headphones intended to be used with personal music players shall comply with the requirements of this sub-clause.</p> <p>The requirements in this sub-clause are valid for music or video mode only.</p> <p>The requirements do not apply:</p> <ul style="list-style-type: none"> – while the personal music player is connected to an external amplifier; or – while the headphones or earphones are not used. <p>NOTE 2 An external amplifier is an amplifier which is not part of the personal music player or the listening device, but which is intended to play the music as a standalone music player.</p> <p>The requirements do not apply to:</p> <ul style="list-style-type: none"> – hearing aid equipment and professional equipment; <p>NOTE 3 Professional equipment is equipment sold through special sales channels. All products sold through normal electronics stores are considered not to be professional equipment.</p>		N/A
	<ul style="list-style-type: none"> – analogue personal music players (personal music players without any kind of digital processing of the sound signal) that are brought to the market before the end of 2015. <p>NOTE 4 This exemption has been allowed because this technology is falling out of use and it is expected that within a few years it will no longer exist. This exemption will not be extended to other technologies.</p> <p>For equipment which is clearly designed or intended for use by young children, the limits of EN 71-1 apply.</p>		N/A

IEC 60950-1			
Clause	Requirement + Test	Result - Remark	Verdict
IEC 60950-1, GROUP DIFFERENCES (CENELEC common modifications EN)			
Clause	Requirement + Test	Result - Remark	Verdict
	<p>Zx.2 Equipment requirements</p> <p>No safety provision is required for equipment that complies with the following:</p> <ul style="list-style-type: none"> – equipment provided as a package (personal music player with its listening device), where the acoustic output $L_{Aeq,T}$ is ≤ 85 dBA measured while playing the fixed “programme simulation noise” as described in EN 50332-1; and – a personal music player provided with an analogue electrical output socket for a listening device, where the electrical output is ≤ 27 mV measured as described in EN 50332-2, while playing the fixed “programme simulation noise” as described in EN 50332-1. <p>NOTE 1 Wherever the term acoustic output is used in this clause, the 30 s A-weighted equivalent sound pressure level $L_{Aeq,T}$ is meant. See also Zx.5 and Annex Zx.</p> <p>All other equipment shall:</p> <ol style="list-style-type: none"> a) protect the user from unintentional acoustic outputs exceeding those mentioned above; and b) have a standard acoustic output level not exceeding those mentioned above, and automatically return to an output level not exceeding those mentioned above when the power is switched off; and 		N/A

IEC 60950-1			
Clause	Requirement + Test	Result - Remark	Verdict

IEC 60950-1, GROUP DIFFERENCES (CENELEC common modifications EN)			
Clause	Requirement + Test	Result - Remark	Verdict
	<p>c) provide a means to actively inform the user of the increased sound pressure when the equipment is operated with an acoustic output exceeding those mentioned above. Any means used shall be acknowledged by the user before activating a mode of operation which allows for an acoustic output exceeding those mentioned above. The acknowledgement does not need to be repeated more than once every 20 h of cumulative listening time; and</p> <p>NOTE 2 Examples of means include visual or audible signals. Action from the user is always required.</p> <p>NOTE 3 The 20 h listening time is the accumulative listening time, independent how often and how long the personal music player has been switched off.</p> <p>d) have a warning as specified in Zx.3; and</p> <p>e) not exceed the following:</p> <ol style="list-style-type: none"> 1) equipment provided as a package (player with its listening device), the acoustic output shall be ≤ 100 dBA measured while playing the fixed "programme simulation noise" described in EN 50332-1; and 2) a personal music player provided with an analogue electrical output socket for a listening device, the electrical output shall be ≤ 150 mV measured as described in EN 50332-2, while playing the fixed "programme simulation noise" described in EN 50332-1. <p>For music where the average sound pressure (long term $L_{Aeq,T}$) measured over the duration of the song is lower than the average produced by the programme simulation noise, the warning does not need to be given as long as the average sound pressure of the song is below the basic limit of 85 dBA. In this case T becomes the duration of the song.</p> <p>NOTE 4 Classical music typically has an average sound pressure (long term $L_{Aeq,T}$) which is much lower than the average programme simulation noise. Therefore, if the player is capable to analyse the song and compare it with the programme simulation noise, the warning does not need to be given as long as the average sound pressure of the song is below the basic limit of 85 dBA.</p> <p>For example, if the player is set with the programme simulation noise to 85 dBA, but the average music level of the song is only 65 dBA, there is no need to give a warning or ask an acknowledgement as long as the average sound level of the song is not above the basic limit of 85 dBA.</p>		N/A

IEC 60950-1			
Clause	Requirement + Test	Result - Remark	Verdict
IEC 60950-1, GROUP DIFFERENCES (CENELEC common modifications EN)			
Clause	Requirement + Test	Result - Remark	Verdict
	<p>Zx.3 Warning The warning shall be placed on the equipment, or on the packaging, or in the instruction manual and shall consist of the following:</p> <ul style="list-style-type: none"> – the symbol of Figure 1 with a minimum height of 5 mm; and – the following wording, or similar: <p>“To prevent possible hearing damage, do not listen at high volume levels for long periods.”</p> <div style="text-align: center;">  </div> <p>Figure 1 – Warning label (IEC 60417-6044)</p> <p>Alternatively, the entire warning may be given through the equipment display during use, when the user is asked to acknowledge activation of the higher level.</p>		N/A
	Zx.4 Requirements for listening devices (headphones and earphones)		N/A
	<p>Zx.4.1 Wired listening devices with analogue input With 94 dBA sound pressure output $L_{Aeq,T}$, the input voltage of the fixed “programme simulation noise” described in EN 50332-2 shall be ≥ 75 mV.</p> <p>This requirement is applicable in any mode where the headphones can operate (active or passive), including any available setting (for example built-in volume level control).</p> <p>NOTE The values of 94 dBA – 75 mV correspond with 85dBA – 27 mV and 100 dBA – 150 mV.</p>		N/A

IEC 60950-1			
Clause	Requirement + Test	Result - Remark	Verdict
IEC 60950-1, GROUP DIFFERENCES (CENELEC common modifications EN)			
Clause	Requirement + Test	Result - Remark	Verdict
	<p>Zx.4.2 Wired listening devices with digital input With any playing device playing the fixed “programme simulation noise” described in EN 50332-1 (and respecting the digital interface standards, where a digital interface standard exists that specifies the equivalent acoustic level), the acoustic output $L_{Aeq,T}$ of the listening device shall be ≤ 100 dBA.</p> <p>This requirement is applicable in any mode where the headphones can operate, including any available setting (for example built-in volume level control, additional sound feature like equalization, etc.).</p> <p>NOTE An example of a wired listening device with digital input is a USB headphone.</p>		N/A
	<p>Zx.4.3 Wireless listening devices In wireless mode: – with any playing and transmitting device playing the fixed programme simulation noise described in EN 50332-1; and – respecting the wireless transmission standards, where an air interface standard exists that specifies the equivalent acoustic level; and – with volume and sound settings in the listening device (for example built-in volume level control, additional sound feature like equalization, etc.) set to the combination of positions that maximize the measured acoustic output for the abovementioned programme simulation noise, the acoustic output $L_{Aeq,T}$ of the listening device shall be ≤ 100 dBA.</p> <p>NOTE An example of a wireless listening device is a Bluetooth headphone.</p>		N/A
	<p>Zx.5 Measurement methods Measurements shall be made in accordance with EN 50332-1 or EN 50332-2 as applicable. Unless stated otherwise, the time interval T shall be 30 s.</p> <p>NOTE Test method for wireless equipment provided without listening device should be defined.</p>		N/A

IEC 60950-1												
Clause	Requirement + Test	Result - Remark	Verdict									
IEC 60950-1, GROUP DIFFERENCES (CENELEC common modifications EN)												
Clause	Requirement + Test	Result - Remark	Verdict									
2.7.1	<p>Replace the subclause as follows:</p> <p>Basic requirements</p> <p>To protect against excessive current, short-circuits and earth faults in PRIMARY CIRCUITS, protective devices shall be included either as integral parts of the equipment or as parts of the building installation, subject to the following, a), b) and c):</p> <p>a) except as detailed in b) and c), protective devices necessary to comply with the requirements of 5.3 shall be included as parts of the equipment;</p> <p>b) for components in series with the mains input to the equipment such as the supply cord, appliance coupler, r.f.i. filter and switch, short-circuit and earth fault protection may be provided by protective devices in the building installation;</p>	<p>No primary circuit in this built-in equipment.</p> <p>Circuits in the equipment considered as secondary circuits.</p>	N/A									
	<p>c) it is permitted for PLUGGABLE EQUIPMENT TYPE B or PERMANENTLY CONNECTED EQUIPMENT, to rely on dedicated overcurrent and short-circuit protection in the building installation, provided that the means of protection, e.g. fuses or circuit breakers, is fully specified in the installation instructions.</p> <p>If reliance is placed on protection in the building installation, the installation instructions shall so state, except that for PLUGGABLE EQUIPMENT TYPE A the building installation shall be regarded as providing protection in accordance with the rating of the wall socket outlet.</p>		N/A									
2.7.2	This subclause has been declared 'void'.		N/A									
3.2.3	Delete the NOTE in Table 3A, and delete also in this table the conduit sizes in parentheses.	The equipment is not directly connection to the mains.	N/A									
3.2.5.1	<p>Replace "60245 IEC 53" by "H05 RR-F";</p> <p>"60227 IEC 52" by "H03 VV-F or H03 VVH2-F";</p> <p>"60227 IEC 53" by "H05 VV-F or H05 VVH2-F2".</p> <p>In Table 3B, replace the first four lines by the following:</p> <table border="0"> <tr> <td>Up to and including 6 </td> <td>0,75 ^{a)} </td> <td>Over 6</td> </tr> <tr> <td>up to and including 10 (0,75) ^{b)}</td> <td>1,0 </td> <td>Over</td> </tr> <tr> <td>10 up to and including 16 (1,0) ^{c)}</td> <td>1,5 </td> <td></td> </tr> </table> <p>In the conditions applicable to Table 3B delete the words "in some countries" in condition ^{a)}.</p> <p>In NOTE 1, applicable to Table 3B, delete the second sentence.</p>	Up to and including 6	0,75 ^{a)}	Over 6	up to and including 10 (0,75) ^{b)}	1,0	Over	10 up to and including 16 (1,0) ^{c)}	1,5		Built-in equipment.	N/A
Up to and including 6	0,75 ^{a)}	Over 6										
up to and including 10 (0,75) ^{b)}	1,0	Over										
10 up to and including 16 (1,0) ^{c)}	1,5											

IEC 60950-1			
Clause	Requirement + Test	Result - Remark	Verdict
IEC 60950-1, GROUP DIFFERENCES (CENELEC common modifications EN)			
Clause	Requirement + Test	Result - Remark	Verdict
3.3.4	In Table 3D, delete the fourth line: conductor sizes for 10 to 13 A, and replace with the following: Over 10 up to and including 16 1,5 to 2,5 1,5 to 4 Delete the fifth line: conductor sizes for 13 to 16 A	Built-in equipment.	N/A
4.3.13.6 (A1:2010)	Replace the existing NOTE by the following: NOTE Z1 Attention is drawn to: 1999/519/EC: Council Recommendation on the limitation of exposure of the general public to electromagnetic fields 0 Hz to 300 GHz, and 2006/25/EC: Directive on the minimum health and safety requirements regarding the exposure of workers to risks arising from physical agents (artificial optical radiation).	No other types of radiation.	N/A
	Standards taking into account mentioned Recommendation and Directive which demonstrate compliance with the applicable EU Directive are indicated in the OJEC.		N/A
Annex H	Replace the last paragraph of this annex by: At any point 10 cm from the surface of the OPERATOR ACCESS AREA, the dose rate shall not exceed 1 μ Sv/h (0,1 mR/h) (see NOTE). Account is taken of the background level. Replace the notes as follows: NOTE These values appear in Directive 96/29/Euratom. Delete NOTE 2.	The unit does not generate Xray radiation.	N/A
Bibliography	Additional EN standards.		—

ZA	NORMATIVE REFERENCES TO INTERNATIONAL PUBLICATIONS WITH THEIR CORRESPONDING EUROPEAN PUBLICATIONS	—
-----------	--	---

ZB ANNEX (normative) SPECIAL NATIONAL CONDITIONS (EN)			
Clause	Requirement + Test	Result - Remark	Verdict
1.2.4.1	In Denmark , certain types of Class I appliances (see 3.2.1.1) may be provided with a plug not establishing earthing conditions when inserted into Danish socket-outlets.	Built-in equipment.	N/A
1.2.13.14	In Norway and Sweden , for requirements see 1.7.2.1 and 7.3 of this annex.		N/A
1.5.7.1	In Finland , Norway and Sweden , resistors bridging BASIC INSULATION in CLASS I PLUGGABLE EQUIPMENT TYPE A must comply with the requirements in 1.5.7.1. In addition when a single resistor is used, the resistor must withstand the resistor test in 1.5.7.2.	Class II equipment.	N/A

IEC 60950-1			
Clause	Requirement + Test	Result - Remark	Verdict
ZB ANNEX (normative)			
SPECIAL NATIONAL CONDITIONS (EN)			
Clause	Requirement + Test	Result - Remark	Verdict
1.5.8	In Norway , due to the IT power system used (see annex V, Figure V.7), capacitors are required to be rated for the applicable line-to-line voltage (230 V).	The equipment is not directly connection to the mains.	N/A
1.5.9.4	In Finland, Norway and Sweden , the third dashed sentence is applicable only to equipment as defined in 6.1.2.2 of this annex.		N/A

IEC 60950-1			
Clause	Requirement + Test	Result - Remark	Verdict
ZB ANNEX (normative)			
SPECIAL NATIONAL CONDITIONS (EN)			
Clause	Requirement + Test	Result - Remark	Verdict
1.7.2.1	<p>In Finland, Norway and Sweden, CLASS I PLUGGABLE EQUIPMENT TYPE A intended for connection to other equipment or a network shall, if safety relies on connection to protective earth or if surge suppressors are connected between the network terminals and accessible parts, have a marking stating that the equipment must be connected to an earthed mains socket-outlet. The marking text in the applicable countries shall be as follows:</p> <p>In Finland: "Laitte on liitettävä suojakoskettimilla varustettuun pistorasiaan"</p> <p>In Norway: "Apparatet må tilkoples jordet stikkontakt"</p> <p>In Sweden: "Apparaten skall anslutas till jordat uttag"</p> <p>In Norway and Sweden, the screen of the cable distribution system is normally not earthed at the entrance of the building and there is normally no equipotential bonding system within the building. Therefore the protective earthing of the building installation need to be isolated from the screen of a cable distribution system.</p> <p>It is however accepted to provide the insulation external to the equipment by an adapter or an interconnection cable with galvanic isolator, which may be provided by e.g. a retailer.</p> <p>The user manual shall then have the following or similar information in Norwegian and Swedish language respectively, depending on in what country the equipment is intended to be used in:</p> <p>"Equipment connected to the protective earthing of the building installation through the mains connection or through other equipment with a connection to protective earthing – and to a cable distribution system using coaxial cable, may in some circumstances create a fire hazard. Connection to a cable distribution system has therefore to be provided through a device providing electrical isolation below a certain frequency range (galvanic isolator, see EN 60728-11)."</p>	<p>No primary circuit in this built-in equipment.</p> <p>Circuits in the equipment considered as secondary circuits.</p> <p>Class II equipment.</p> <p>The equipment is not connect to cable distribution system.</p>	N/A

IEC 60950-1			
Clause	Requirement + Test	Result - Remark	Verdict
ZB ANNEX (normative) SPECIAL NATIONAL CONDITIONS (EN)			
Clause	Requirement + Test	Result - Remark	Verdict
	<p>NOTE In Norway, due to regulation for installations of cable distribution systems, and in Sweden, a galvanic isolator shall provide electrical insulation below 5 MHz. The insulation shall withstand a dielectric strength of 1,5 kV r.m.s., 50 Hz or 60 Hz, for 1 min.</p> <p>Translation to Norwegian (the Swedish text will also be accepted in Norway): "Utstyr som er koplet til beskyttelsesjord via nettplugg og/eller via annet jordtilkoplede utstyr – og er tilkoplede et kabel-TV nett, kan forårsake brannfare. For å unngå dette skal det ved tilkopling av utstyret til kabel-TV nettet installeres en galvanisk isolator mellom utstyret og kabel-TV nettet." Translation to Swedish: "Utrustning som är kopplad till skyddsjord via jordat vägguttag och/eller via annan utrustning och samtidigt är kopplad till kabel-TV nät kan i vissa fall medföra risk för brand. För att undvika detta skall vid anslutning av utrustningen till kabel-TV nät galvanisk isolator finnas mellan utrustningen och kabel-TV nätet."</p>		
1.7.5	<p>In Denmark, socket-outlets for providing power to other equipment shall be in accordance with the Heavy Current Regulations, Section 107-2-D1, Standard Sheet DK 1-3a, DK 1-5a or DK 1-7a, when used on Class I equipment. For STATIONARY EQUIPMENT the socket-outlet shall be in accordance with Standard Sheet DK 1-1b or DK 1-5a.</p> <p>For CLASS II EQUIPMENT the socket outlet shall be in accordance with Standard Sheet DKA 1-4a.</p>	No such socket-outlet.	N/A
2.2.4	In Norway , for requirements see 1.7.2.1, 6.1.2.1 and 6.1.2.2 of this annex.	No TNV circuits.	N/A
2.3.2	In Finland, Norway and Sweden there are additional requirements for the insulation. See 6.1.2.1 and 6.1.2.2 of this annex.	No TNV circuits.	N/A
2.3.4	In Norway , for requirements see 1.7.2.1, 6.1.2.1 and 6.1.2.2 of this annex.	No TNV circuits.	N/A
2.6.3.3	In the United Kingdom , the current rating of the circuit shall be taken as 13 A, not 16 A.	Class II equipment.	N/A
2.7.1	In the United Kingdom , to protect against excessive currents and short-circuits in the PRIMARY CIRCUIT of DIRECT PLUG-IN EQUIPMENT, tests according to 5.3 shall be conducted, using an external protective device rated 30 A or 32 A. If these tests fail, suitable protective devices shall be included as integral parts of the DIRECT PLUG-IN EQUIPMENT, so that the requirements of 5.3 are met.	Not direct plug-in equipment.	N/A

IEC 60950-1			
Clause	Requirement + Test	Result - Remark	Verdict
ZB ANNEX (normative) SPECIAL NATIONAL CONDITIONS (EN)			
Clause	Requirement + Test	Result - Remark	Verdict
2.10.5.13	In Finland, Norway and Sweden , there are additional requirements for the insulation, see 6.1.2.1 and 6.1.2.2 of this annex.	No TNV circuits	N/A
3.2.1.1	<p>In Switzerland, supply cords of equipment having a RATED CURRENT not exceeding 10 A shall be provided with a plug complying with SEV 1011 or IEC 60884-1 and one of the following dimension sheets:</p> <p>SEV 6532-2.1991 Plug Type 15 3P+N+PE 250/400 V, 10 A</p> <p>SEV 6533-2.1991 Plug Type 11 L+N 250 V, 10 A</p> <p>SEV 6534-2.1991 Plug Type 12 L+N+PE 250 V, 10 A</p> <p>In general, EN 60309 applies for plugs for currents exceeding 10 A. However, a 16 A plug and socket-outlet system is being introduced in Switzerland, the plugs of which are according to the following dimension sheets, published in February 1998:</p> <p>SEV 5932-2.1998: Plug Type 25 , 3L+N+PE 230/400 V, 16 A</p> <p>SEV 5933-2.1998: Plug Type 21, L+N, 250 V, 16A</p> <p>SEV 5934-2.1998: Plug Type 23, L+N+PE 250 V, 16 A</p>	<p>No primary circuit in this built-in equipment.</p> <p>Circuits in the equipment considered as secondary circuits.</p>	N/A
3.2.1.1	<p>In Denmark, supply cords of single-phase equipment having a rated current not exceeding 13 A shall be provided with a plug according to the Heavy Current Regulations, Section 107-2-D1.</p> <p>CLASS I EQUIPMENT provided with socket-outlets with earth contacts or which are intended to be used in locations where protection against indirect contact is required according to the wiring rules shall be provided with a plug in accordance with standard sheet DK 2-1a or DK 2-5a.</p> <p>If poly-phase equipment and single-phase equipment having a RATED CURRENT exceeding 13 A is provided with a supply cord with a plug, this plug shall be in accordance with the Heavy Current Regulations, Section 107-2-D1 or EN 60309-2.</p>	<p>No primary circuit in this built-in equipment.</p> <p>Circuits in the equipment considered as secondary circuits.</p> <p>Class II equipment.</p>	N/A

IEC 60950-1			
Clause	Requirement + Test	Result - Remark	Verdict
ZB ANNEX (normative) SPECIAL NATIONAL CONDITIONS (EN)			
Clause	Requirement + Test	Result - Remark	Verdict
3.2.1.1	<p>In Spain, supply cords of single-phase equipment having a rated current not exceeding 10 A shall be provided with a plug according to UNE 20315:1994.</p> <p>Supply cords of single-phase equipment having a rated current not exceeding 2,5 A shall be provided with a plug according to UNE-EN 50075:1993.</p> <p>CLASS I EQUIPMENT provided with socket-outlets with earth contacts or which are intended to be used in locations where protection against indirect contact is required according to the wiring rules, shall be provided with a plug in accordance with standard UNE 20315:1994.</p> <p>If poly-phase equipment is provided with a supply cord with a plug, this plug shall be in accordance with UNE-EN 60309-2.</p>	<p>No primary circuit in this built-in equipment.</p> <p>Circuits in the equipment considered as secondary circuits.</p> <p>Class II equipment.</p>	N/A
3.2.1.1	<p>In the United Kingdom, apparatus which is fitted with a flexible cable or cord and is designed to be connected to a mains socket conforming to BS 1363 by means of that flexible cable or cord and plug, shall be fitted with a 'standard plug' in accordance with Statutory Instrument 1768:1994 - The Plugs and Sockets etc. (Safety) Regulations 1994, unless exempted by those regulations.</p> <p>NOTE 'Standard plug' is defined in SI 1768:1994 and essentially means an approved plug conforming to BS 1363 or an approved conversion plug.</p>	<p>No primary circuit in this built-in equipment.</p> <p>Circuits in the equipment considered as secondary circuits.</p>	N/A
3.2.1.1	<p>In Ireland, apparatus which is fitted with a flexible cable or cord and is designed to be connected to a mains socket conforming to I.S. 411 by means of that flexible cable or cord and plug, shall be fitted with a 13 A plug in accordance with Statutory Instrument 525:1997 - National Standards Authority of Ireland (section 28) (13 A Plugs and Conversion Adaptors for Domestic Use) Regulations 1997.</p>	<p>No primary circuit in this built-in equipment.</p> <p>Circuits in the equipment considered as secondary circuits.</p>	N/A
3.2.4	<p>In Switzerland, for requirements see 3.2.1.1 of this annex.</p>		N/A
3.2.5.1	<p>In the United Kingdom, a power supply cord with conductor of 1,25 mm² is allowed for equipment with a rated current over 10 A and up to and including 13 A.</p>	<p>No primary circuit in this built-in equipment.</p> <p>Circuits in the equipment considered as secondary circuits.</p>	N/A

IEC 60950-1			
Clause	Requirement + Test	Result - Remark	Verdict
ZB ANNEX (normative) SPECIAL NATIONAL CONDITIONS (EN)			
Clause	Requirement + Test	Result - Remark	Verdict
3.3.4	In the United Kingdom , the range of conductor sizes of flexible cords to be accepted by terminals for equipment with a RATED CURRENT of over 10 A up to and including 13 A is: • 1,25 mm ² to 1,5 mm ² nominal cross-sectional area.	No primary circuit in this built-in equipment. Circuits in the equipment considered as secondary circuits.	N/A
4.3.6	In the United Kingdom , the torque test is performed using a socket outlet complying with BS 1363 part 1:1995, including Amendment 1:1997 and Amendment 2:2003 and the plug part of DIRECT PLUG-IN EQUIPMENT shall be assessed to BS 1363: Part 1, 12.1, 12.2, 12.3, 12.9, 12.11, 12.12, 12.13, 12.16 and 12.17, except that the test of 12.17 is performed at not less than 125 °C. Where the metal earth pin is replaced by an Insulated Shutter Opening Device (ISOD), the requirements of clauses 22.2 and 23 also apply.	No such socket outlet.	N/A
4.3.6	In Ireland , DIRECT PLUG-IN EQUIPMENT is known as plug similar devices. Such devices shall comply with Statutory Instrument 526:1997 - National Standards Authority of Ireland (Section 28) (Electrical plugs, plug similar devices and sockets for domestic use) Regulations, 1997.	Not direct plug-in equipment.	N/A
5.1.7.1	In Finland, Norway and Sweden TOUCH CURRENT measurement results exceeding 3,5 mA r.m.s. are permitted only for the following equipment: • STATIONARY PLUGGABLE EQUIPMENT TYPE A that is intended to be used in a RESTRICTED ACCESS LOCATION where equipotential bonding has been applied, for example, in a telecommunication centre; and has provision for a permanently connected PROTECTIVE EARTHING CONDUCTOR; and is provided with instructions for the installation of that conductor by a SERVICE PERSON; • STATIONARY PLUGGABLE EQUIPMENT TYPE B; • STATIONARY PERMANENTLY CONNECTED EQUIPMENT.	No primary circuit in this built-in equipment. Circuits in the equipment considered as secondary circuits. Compliance shall be evaluated with the end product.	N/A

IEC 60950-1			
Clause	Requirement + Test	Result - Remark	Verdict
ZB ANNEX (normative) SPECIAL NATIONAL CONDITIONS (EN)			
Clause	Requirement + Test	Result - Remark	Verdict
6.1.2.1 (A1:2010)	<p>In Finland, Norway and Sweden, add the following text between the first and second paragraph of the compliance clause:</p> <p>If this insulation is solid, including insulation forming part of a component, it shall at least consist of either</p> <ul style="list-style-type: none"> - two layers of thin sheet material, each of which shall pass the electric strength test below, or - one layer having a distance through insulation of at least 0,4 mm, which shall pass the electric strength test below. <p>Alternatively for components, there is no distance through insulation requirements for the insulation consisting of an insulating compound completely filling the casing, so that CLEARANCES and CREEPAGE DISTANCES do not exist, if the component passes the electric strength test in accordance with the compliance clause below and in addition</p> <ul style="list-style-type: none"> - passes the tests and inspection criteria of 2.10.11 with an electric strength test of 1,5 kV multiplied by 1,6 (the electric strength test of 2.10.10 shall be performed using 1,5 kV), and - is subject to ROUTINE TESTING for electric strength during manufacturing, using a test voltage of 1,5 kV. 	No TNV circuits.	N/A
	<p>It is permitted to bridge this insulation with an optocoupler complying with 2.10.5.4 b).</p> <p>It is permitted to bridge this insulation with a capacitor complying with EN 60384-14:2005, subclass Y2.</p> <p>A capacitor classified Y3 according to EN 60384-14:2005, may bridge this insulation under the following conditions:</p> <ul style="list-style-type: none"> - the insulation requirements are satisfied by having a capacitor classified Y3 as defined by EN 60384-14, which in addition to the Y3 testing, is tested with an impulse test of 2,5 kV defined in EN 60950-1:2006, 6.2.2.1; - the additional testing shall be performed on all the test specimens as described in EN 60384-14: - the impulse test of 2,5 kV is to be performed before the endurance test in EN 60384-14, in the sequence of tests as described in EN 60384-14. 		N/A

IEC 60950-1			
Clause	Requirement + Test	Result - Remark	Verdict
ZB ANNEX (normative) SPECIAL NATIONAL CONDITIONS (EN)			
Clause	Requirement + Test	Result - Remark	Verdict
6.1.2.2	In Finland, Norway and Sweden , the exclusions are applicable for PERMANENTLY CONNECTED EQUIPMENT, PLUGGABLE EQUIPMENT TYPE B and equipment intended to be used in a RESTRICTED ACCESS LOCATION where equipotential bonding has been applied, e.g. in a telecommunication centre, and which has provision for a permanently connected PROTECTIVE EARTHING CONDUCTOR and is provided with instructions for the installation of that conductor by a SERVICE PERSON.	No TNV circuits.	N/A
7.2	In Finland, Norway and Sweden , for requirements see 6.1.2.1 and 6.1.2.2 of this annex. The term TELECOMMUNICATION NETWORK in 6.1.2 being replaced by the term CABLE DISTRIBUTION SYSTEM.	Not cable distribution system.	N/A
7.3	In Norway and Sweden , for requirements see 1.2.13.14 and 1.7.2.1 of this annex.	Not cable distribution system.	N/A
7.3	In Norway , for installation conditions see EN 60728-11:2005.	Not cable distribution system.	N/A

ATTACHMENT TO TEST REPORT IEC 60950-1 AUSTRALIAN / NEW ZEALAND DIFFERENCES			
Differences according to: AS/NZS 60950.1:2011			
IEC Standard: 60950-1(ed.2)			
Last Modification: Date (2011-05-06)			
Clause	Requirement + Test	Result - Remark	Verdict
ZZ.1 Introduction			
This Appendix sets out variations and additional requirements to cover issues which have not been addressed by the International Standard. These variations indicate national variations for purposes of the IEC CB System and will be published in the IEC CB Bulletin.			
ZZ.2 Variations			
The variations are as follows:			
1.2	Between the definitions for 'Person, service' and 'Range, rated frequency' <i>insert</i> the following: POTENTIAL IGNITION SOURCE 1.2.12.201	Considered.	—
1.2.12.15	After the definition 1.2.12.15, <i>add</i> the following: 1.2.12.201 POTENTIAL IGNITION SOURCE: Possible fault which can start a fire if the open- circuit voltage measured across an interruption or faulty contact exceeds a value of 50 V (peak) a.c. or d.c. and the product of the peak value of this voltage and the measured r.m.s. current under normal operating conditions exceeds 15 VA. Such a faulty contact or interruption in an electrical connection includes those which may occur in CONDUCTIVE PATTERNS on PRINTED BOARDS. NOTE 201: An electronic protection circuit may be used to prevent such a fault from becoming a POTENTIAL IGNITION SOURCE. NOTE 202: This definition is from AS/NZS 60065:2003.	Considered.	—
1.5.1	Add the following to the end of first paragraph: 'or the relevant Australian/New Zealand Standard'.	All critical components are IEC or UL certified.	P
1.5.2	Add the following to the end of first and third dash items: 'or the relevant Australian/New Zealand Standard'.	All critical components are IEC or UL certified.	P

3.2.5.1	<p>Modify Table 3B as follows: Delete the first four rows and replace with</p> <table border="1" data-bbox="379 297 956 488"> <thead> <tr> <th rowspan="2">RATED CURRENT OF EQUIPMENT A</th> <th colspan="3">Minimum conductor sizes</th> </tr> <tr> <th>Nominal cross-sectional area mm²</th> <th></th> <th>AWG or kcmil [cross-sectional area in mm²] see note 2</th> </tr> </thead> <tbody> <tr> <td>Over 0.2 up to and including 3</td> <td></td> <td>0,5 ¹⁾</td> <td>18 [0,8]</td> </tr> <tr> <td>Over 3 up to and including 7.5</td> <td></td> <td>0,75</td> <td>16 [1,3]</td> </tr> <tr> <td>Over 7.5 up to and including 10</td> <td>(0,75)²⁾</td> <td>1,00</td> <td>16 [1,3]</td> </tr> <tr> <td>Over 10 up to and including 16</td> <td>(1,0)³⁾</td> <td>1,5</td> <td>14 [2]</td> </tr> </tbody> </table> <p>Replace footnote 1) with the following:</p> <p>¹⁾ This nominal cross-sectional area is only allowed for Class II appliances if the length of the power supply cord, measured between the point where the cord, or cord guard, enters the appliance, and the entry to the plug does not exceed 2 m (0.5 mm² three-core supply flexible cords are not permitted; see AS/NZS 3191).</p> <p>Delete Note 1.</p>	RATED CURRENT OF EQUIPMENT A	Minimum conductor sizes			Nominal cross-sectional area mm ²		AWG or kcmil [cross-sectional area in mm ²] see note 2	Over 0.2 up to and including 3		0,5 ¹⁾	18 [0,8]	Over 3 up to and including 7.5		0,75	16 [1,3]	Over 7.5 up to and including 10	(0,75) ²⁾	1,00	16 [1,3]	Over 10 up to and including 16	(1,0) ³⁾	1,5	14 [2]	<p>Built-in equipment, and no power supply cord provided. Compliance shall be evaluated with the end product.</p>	N/A
RATED CURRENT OF EQUIPMENT A	Minimum conductor sizes																									
	Nominal cross-sectional area mm ²		AWG or kcmil [cross-sectional area in mm ²] see note 2																							
Over 0.2 up to and including 3		0,5 ¹⁾	18 [0,8]																							
Over 3 up to and including 7.5		0,75	16 [1,3]																							
Over 7.5 up to and including 10	(0,75) ²⁾	1,00	16 [1,3]																							
Over 10 up to and including 16	(1,0) ³⁾	1,5	14 [2]																							
4.1.201	<p>Add the following after the last Paragraph of Clause 4.1:</p> <p>4.1.201 Display devices used for television purposes</p> <p>Display devices which may be used for television purposes, with a mass of 7 kg or more, shall comply with the requirements for stability and mechanical hazards, including the additional stability requirements for television receivers, specified in AS/NZS 60065.</p>	No such device used.	N/A																							
4.3.6	<p>Replace paragraph three with:</p> <p>Equipment with a plug portion, suitable for insertion into a 10 A 3-pin flat-pin socket-outlet complying with AS/NZS 3112, shall comply with the requirements in AS/NZS 3112 for equipment with integral pins for insertion into socket-outlets.</p>	Not direct plug-in equipment.	N/A																							
4.3.13.5	<p>Add the following to the end of first paragraph: 'or AS/NZS 2211.1'.</p>	No Laser product used.	N/A																							
4.7	<p>Add the following paragraph: For alternative tests refer to Clause 4.7.201.</p>	<p>Built-in equipment. Compliance shall be evaluated with the end product.</p>	N/A																							

4.7.201	<p>Add the following after Clause 4.7.3.6:</p> <p>4.7.201 Resistance to fire – Alternative tests</p> <p>4.7.201.1 General</p> <p>Parts of non-metallic material shall be resistant to ignition and spread of fire.</p> <p>This requirement does not apply to decorative trims, knobs and other parts unlikely to be ignited or to propagate flames originating from inside the apparatus, or the following:</p> <p>a) Components that are contained in an enclosure having a flammability category of FV-0 according to AS/NZS 4695.707 and having openings only for the connecting wires filling the openings completely, and for ventilation not exceeding 1 mm in width regardless of length.</p> <p>b) The following parts which would contribute negligible fuel to a fire:</p> <ul style="list-style-type: none"> - small mechanical parts, the mass of which does not exceed 4 g, such as mounting parts, gears, cams, belts and bearings; - small electrical components, such as capacitors with a volume not exceeding 1750mm³, integrated circuits, transistors and optocoupler packages, if these components are mounted on material of flammability category FV-1, or better, according to AS/NZS 4695.707. <p>NOTE: In considering how to minimize propagation of fire and what 'small parts' are, account should be taken of the cumulative effect of small parts adjacent to each other for the possible effect of propagating fire from one part to another.</p> <p>Compliance shall be checked by the tests of 4.7.201.2, 4.7.201.3, 4.7.201.4 and 4.7.201.5.</p> <p>For the base material of printed boards, compliance shall be checked by the test of 4.7.201.5.</p> <p>The tests shall be carried out on parts of non-metallic material which have been removed from the apparatus. When the glow-wire test is carried out, the parts shall be placed in the same orientation as they would be in normal use.</p> <p>These tests are not carried out on internal wiring.</p> <p>4.7.201.2 Testing of non-metallic materials</p> <p>Parts of non-metallic material shall be subject to the glow-wire test of AS/NZS 60695.2.11 which shall be carried out at 550°C.</p>	<p>Built-in equipment.</p> <p>Compliance shall be evaluated with the end product.</p>	N/A
---------	---	---	-----

<p>4.7.201</p>	<p>Parts for which the glow-wire test cannot be carried out, such as those made of soft or foamy material, shall meet the requirements specified in ISO 9772 for category FH-3 material. The glow-wire test shall not be carried out on parts of material classified at least FH-3 according to ISO 9772 provided that the sample tested was not thicker than the relevant part.</p> <p>4.7.201.3 Testing of insulating materials</p> <p>Parts of insulating material supporting POTENTIAL IGNITION SOURCES shall be subject to the glow-wire test of AS/NZS 60695.2.11 which shall be carried out at 750°C</p> <p>The test shall also be carried out on other parts of insulating material which are within a distance of 3 mm of the connection.</p> <p>NOTE: Contacts in components such as switch contacts are considered to be connections.</p> <p>For parts which withstand the glow-wire test but produce a flame, other parts above the connection within the envelope of a vertical cylinder having a diameter of 20 mm and a height of 50 mm shall be subjected to the needle-flame test. However, parts shielded by a barrier which meets the needle-flame test shall not be tested. The needle-flame test shall be made in accordance with AS/NZS 4695.2.2 with the following modifications:</p> <table border="1" data-bbox="384 1059 799 1552"> <thead> <tr> <th>Clause of AS/NZS 4695.2.2</th> <th>Change</th> </tr> </thead> <tbody> <tr> <td>8.1</td> <td> <p>Revert to:</p> <p>The duration of application of the test flame shall be 30 s ± 1 s.</p> </td> </tr> <tr> <td>8.2</td> <td> <p>Replace the first sentence with:</p> <p>The specimen shall be arranged so that the flame can be applied to a vertical or horizontal edge as shown in the examples of figure 1.</p> </td> </tr> <tr> <td>8.4</td> <td> <p>The first paragraph does not apply.</p> <p>Add:</p> <p>If possible, the flame shall be applied at least 10 mm from a corner.</p> </td> </tr> <tr> <td>8.5</td> <td> <p>Replace with:</p> <p>The test shall be made on one specimen. If the specimen does not withstand the test, the test may be repeated on two further specimens, both of which shall then withstand the test.</p> </td> </tr> <tr> <td>9.0 Evaluation of test results</td> <td> <p>Replace with:</p> <p>The duration of burning (t_b) shall not exceed 30 s. However, for printed circuit boards, it shall not exceed 15 s.</p> </td> </tr> </tbody> </table>	Clause of AS/NZS 4695.2.2	Change	8.1	<p>Revert to:</p> <p>The duration of application of the test flame shall be 30 s ± 1 s.</p>	8.2	<p>Replace the first sentence with:</p> <p>The specimen shall be arranged so that the flame can be applied to a vertical or horizontal edge as shown in the examples of figure 1.</p>	8.4	<p>The first paragraph does not apply.</p> <p>Add:</p> <p>If possible, the flame shall be applied at least 10 mm from a corner.</p>	8.5	<p>Replace with:</p> <p>The test shall be made on one specimen. If the specimen does not withstand the test, the test may be repeated on two further specimens, both of which shall then withstand the test.</p>	9.0 Evaluation of test results	<p>Replace with:</p> <p>The duration of burning (t_b) shall not exceed 30 s. However, for printed circuit boards, it shall not exceed 15 s.</p>	<p>Built-in equipment. Compliance shall be evaluated with the end product.</p>	<p>N/A</p>
Clause of AS/NZS 4695.2.2	Change														
8.1	<p>Revert to:</p> <p>The duration of application of the test flame shall be 30 s ± 1 s.</p>														
8.2	<p>Replace the first sentence with:</p> <p>The specimen shall be arranged so that the flame can be applied to a vertical or horizontal edge as shown in the examples of figure 1.</p>														
8.4	<p>The first paragraph does not apply.</p> <p>Add:</p> <p>If possible, the flame shall be applied at least 10 mm from a corner.</p>														
8.5	<p>Replace with:</p> <p>The test shall be made on one specimen. If the specimen does not withstand the test, the test may be repeated on two further specimens, both of which shall then withstand the test.</p>														
9.0 Evaluation of test results	<p>Replace with:</p> <p>The duration of burning (t_b) shall not exceed 30 s. However, for printed circuit boards, it shall not exceed 15 s.</p>														

4.7.201	<p>The needle-flame test shall not be carried out on parts of material classified as V-0 or V-1 according to IEC 60695-11-10, provided that the sample tested was not thicker than the relevant part.</p> <p>4.7.201.4 Testing in the event of non-extinguishing material</p> <p>If the parts, other than enclosures, do not withstand the glow-wire tests of 4.7.201.3, by failure to extinguish within 30 s after the removal of the glow-wire tip, the needle-flame test detailed in 4.7.201.3 shall be made on all parts of non-metallic material which are within a distance of 50 mm or which are likely to be impinged upon by flame during tests of 4.7.201.3. Parts shielded by a separate barrier which meets the needle-flame test need not be tested.</p> <p>NOTE 1: If the enclosure does not withstand the glow-wire test the equipment is considered to have failed to meet the requirements of Clause 4.7.201 without the need for consequential testing.</p> <p>NOTE 2: If other parts do not withstand the glow-wire test due to ignition of the tissue paper and if this indicates that burning or glowing particles can fall onto an external surface underneath the equipment, the equipment is considered to have failed to meet the requirements of Clause 4.7.201 without the need for consequential testing.</p> <p>NOTE 3: Parts likely to be impinged upon by the flame are considered to be those within the envelope of a vertical cylinder having a radius of 10 mm and a height equal to the height of the flame, positioned above the point of the material supporting, in contact with, or in close proximity to, connections.</p>	<p>Built-in equipment. Compliance shall be evaluated with the end product.</p>	N/A
---------	--	--	-----

4.7.201	<p>4.7.201.5 Testing of printed boards</p> <p>The base material of printed boards shall be subjected to the needle-flame test of Clause 4.7.201.3. The flame shall be applied to the edge of the board where the heat sink effect is lowest when the board is positioned as in normal use. The flame shall not be applied to an edge, consisting of broken perforations, unless the edge is less than 3 mm from a POTENTIAL IGNITION SOURCE.</p> <p>The test is not carried out if the –</p> <ul style="list-style-type: none"> - Printed board does not carry any POTENTIAL IGNITION SOURCE; - Base material of printed boards, on which the available apparent power at a connection exceeds 15 VA operating at a voltage exceeding 50 V and equal or less than 400 V (peak) a.c. or d.c. under normal operating conditions, is of flammability category FV-1 or better according to AS/NZS 4695.707, or the printed boards are protected by an enclosure meeting the flammability category FV-0 according to AS/NZS 4695.707, or made of metal, having openings only for connecting wires which fill the openings completely; or - Base material of printed boards, on which the available apparent power at a connection exceeds 15 VA operating at a voltage exceeding 400 V (peak) a.c. or d.c. under normal operating conditions, and base material of printed boards supporting spark gaps which provides protection against overvoltages, is of flammability category FV-0 according to AS/NZS 4695.707 or the printed boards are contained in a metal enclosure, having openings only for connecting wires which fill the openings completely. <p>Compliance shall be determined using the smallest thickness of the material.</p> <p>NOTE: Available apparent power is the maximum apparent power which can be drawn from the supplying circuit through a resistive load whose value is chosen to maximise the apparent power from more than 2 min when the circuit supplied is disconnected.</p>	Built-in equipment. Compliance shall be evaluated with the end product.	N/A
6.2.2	<p><i>Add</i> the symbol [NZ] in the right hand margin beside the first paragraph.</p> <p><i>Add</i> the following after the first paragraph:</p> <p>In Australia (this variation does not apply in New Zealand), compliance with 6.2.2 shall be checked by the tests of both 6.2.2.1 and 6.2.2.2.</p> <p><i>Delete</i> the Note.</p>	No TNV circuitry.	N/A

6.2.2.1	<p>Add the symbol [NZ] in the right hand margin beside the first paragraph including Note 1.</p> <p>Delete the Note 2.</p> <p>Add the following after the first paragraph:</p> <p>In Australia (this variation does not apply in New Zealand), the electrical separation is subjected to 10 impulses of alternating polarity, using the impulse test generator of annex N for 10/700µs impulses. The interval between successive impulses is 60 s and the initial voltage, U_c, is:</p> <ul style="list-style-type: none"> - for 6.2.1 a): 7.0 kV for hand-held telephones and for headsets and 2.5 kV for other equipment; and - for 6.2.1 b) and 6.2.1 c): 1.5 kV. <p>NOTE 201: The 7 kV impulse simulates lightning surges on typical rural and semi-rural network lines.</p> <p>NOTE 202: The 2.5 kV for 6.2.1 a) was chosen to ensure adequacy of the insulation concerned and does not necessarily simulate likely overvoltages.</p>	No TNV circuitry.	N/A
6.2.2.2	<p>Add the symbol [NZ] in the right hand margin beside the second paragraph.</p> <p>Delete the Note.</p> <p>Add the following after the second paragraph:</p> <p>In Australia (this variation does not apply in New Zealand), the a.c. test voltage is:</p> <ul style="list-style-type: none"> - for 6.2.1 a): 3 kV; and - for 6.2.1 b) and 6.2.1 c): 1.5 kV. <p>NOTE 201: Where there are capacitors across the insulation under test, it is recommended that d.c. test voltages are used.</p> <p>NOTE 202: The 3 kV and 1.5 kV values have been determined considering the low frequency induced voltages from the power supply distribution system.</p>	No TNV circuitry.	N/A
7.2	<p>Add the following before the first paragraph:</p> <p>Equipment providing functions that fall only within the scope of AS/NZS 60065 and that incorporate a PSTN interface, are not required to comply with this Clause where the only ports provided on the equipment, in addition to a coaxial cable connection and a PSTN interface, are audio or video ports and analogue or data ports not intended to be used for telecommunications purposes.</p>	No CDS.	N/A

Annex P	<p>Add the following Normative References to Annex P:</p> <p>IEC 60065, <i>Audio, Video and similar electronic apparatus – Safety requirements</i></p> <p>AS/NZS 3191, <i>Approval and test specification – Electric flexible cords</i></p> <p>AS/NZS 3112, <i>Approval and test specification – Plugs and socket-outlets</i></p> <p>AS/NZS 4695.707, <i>Fire hazard testing of electrotechnical products – Methods of test for the determination of the flammability of solid electrical insulating materials when exposed to an igniting source</i></p>	Considered.	P
Index	<p>1. <i>Insert</i> the following between ‘asbestos, not to be used as insulation’ and ‘attitude see orientation’:</p> <p>AS/NZS 2211.1.....4.3.13.5</p> <p>AS/NZS 3112.....4.3.6</p> <p>AS/NZS 3191..... 3.2.5.1 (Table 3B)</p> <p>AS/NZS 60064.....4.1.201</p> <p>AS/NZS 60695.2.11..... 4.7.201.2, 4.7.201.3</p> <p>AS/NZS 60695.11.10..... 4.7.201.1, 4.7.201.5</p> <p>AS/NZS 60695.11.5.....4.7.201.3</p> <p>2. <i>Insert</i> the following between ‘positive temperature coefficient (PTC) device’ and ‘powder’:</p> <p>potential ignition source 1.2.201, 4.7.201.3, 4.7.201.5</p>	Considered.	—

IEC60950-1C ATTACHMENT			
Clause	Requirement + Test	Result - Remark	Verdict

**ATTACHMENT TO TEST REPORT IEC 60950-1
CANADA NATIONAL DIFFERENCES**

Information technology equipment – Safety –
Part 1: General requirements

Differences according to.....: CAN/CSA-C22.2 NO. 60950-1A-07

Attachment Form No.....: CA_ND_IEC60950_1C

Attachment Originator: TÜV SÜD Product Service GmbH

Master Attachment.....: Date (2012-08)

Copyright © 2012 IEC System for Conformity Testing and Certification of Electrical Equipment (IECEE), Geneva, Switzerland. All rights reserved.

	Special national conditions		
1.1.1	All equipment is to be designed to allow installation in accordance with the National Electrical Code (NEC), ANSI/NFPA 70, the Canadian Electrical Code (CEC), Part I, CAN/CSA C22.1, and when applicable, the National Electrical Safety Code, IEEE C2.	Built-in equipment. Must be considered in the end product.	—
	Also, unless marked or otherwise identified, installation is allowed per the Standard for the Protection of Electronic Computer/Data-Processing Equipment, ANSI/NFPA 75.		N/A
1.4.14	For Pluggable Equipment Type A, the protection in the installation is assumed to be 20A.	Built-in equipment, not directly connect to AC mains supply.	N/A
1.5.5	For lengths exceeding 3.05 m, external interconnecting flexible cord and cable assemblies are required to be a suitable cable type (e.g., DP, CL2) specified in the CEC/NEC.	Built-in equipment, not directly connect to AC mains supply. Compliance shall be evaluated with the end product.	N/A
	For lengths 3.05 m or less, external interconnecting flexible cord and cable assemblies that are not types specified in the CEC are required to have special construction features and identification markings.		N/A
1.7.1	Equipment for use on a.c. mains supply systems with a neutral and more than one phase conductor (e.g. 120/240 V, 3-wire) require a special marking format for electrical ratings.	Built-in equipment, not directly connect to AC mains supply.	N/A
	A voltage rating that exceeds an attachment plug cap rating is only permitted if it does not exceed the extreme operating conditions in Table 2 of CAN/CSA C22.2 No. 235, and		N/A
	- if it is part of a range that extends into the Table 2 "Normal Operating Conditions."		N/A

IEC60950-1C ATTACHMENT			
Clause	Requirement + Test	Result - Remark	Verdict
	A voltage rating is not be lower than the specified "Normal Operating Conditions," unless it is part of a range that extends into the "Normal Operating Conditions."		N/A
1.7.7	Wiring terminals intended to supply Class 2 outputs in accordance with CEC Part 1 or NEC are marked with the voltage rating and "Class 2" or equivalent.	No such terminal.	N/A
	- Marking is located adjacent to the terminals		N/A
	- Marking is visible during wiring		N/A
2.5	Fuse providing Class 2, Limited Power Source, or TNV current limiting is not operator-accessible unless it is not interchangeable.		N/A
2.6.3.3	Modify first column on Table 2D to "Smaller of the RATED CURRENT of the equipment or the PROTECTIVE CURRENT RATING of the circuit under consideration."		N/A
2.7.1	Suitable NEC/CEC branch circuit protection rated at the maximum circuit rating is provided for all standard supply outlets and receptacles (such as supplied in power distribution units) if the supply branch circuit protection is not suitable.	No standard supply outlets, receptacles, lampholders or such transformers.	N/A
	Power distribution transformers distributing power at 100 volts or more, and rated 10 kVA or more, provided with special transformer overcurrent protection.		N/A
3.2	Wiring methods (terminals, leads, etc.) used for the connection of the equipment to the mains is in accordance with the NEC/CEC.	Built-in equipment. Must be considered in the end product.	—
3.2.1	Attachment plugs of power supply cords are rated not less than 125 percent of the rated current of the equipment.		—
3.2.1.2	Equipment connected to a centralized d.c. power system, and having one pole of the DC mains input terminal connected to the main protective earthing terminal in the equipment comply with special earthing, wiring, marking and installation instruction requirements.	The equipment not connected to DC power system.	—
3.2.3	Permanent connection of equipment to the mains supply by a power supply cord is not permitted, except for certain equipment, such as ATMs.		—
3.2.5	Power supply cords are no longer than 4.5 m in length.	Built-in equipment, not directly connect to AC mains supply. Compliance shall be evaluated with the end product.	—

IEC60950-1C ATTACHMENT			
Clause	Requirement + Test	Result - Remark	Verdict
	Minimum cord length is 1.5 m, with certain constructions such as external power supplies allowed to consider both input and output cord lengths into the requirement.		—
	Flexible power supply cords are compatible with Article 400 of the NEC, and Tables 11 and 12 of the CEC.		—
3.2.9	Permanently connected equipment have a suitable wiring compartment and wire bending space.	Not permanently connected equipment.	—
3.3	Wiring terminals and associated spacings for field wiring connections comply with CSA C22.2 No. 0.	Built-in equipment. Must be considered in the end product.	—
3.3.3	Wire binding screws are not permitted to attach conductors larger than 10 AWG (5.3 mm2).		—
3.3.4	Terminals for permanent wiring, including protective earthing terminals, are suitable for Canadian/US wire gauge sizes, are		—
	- rated 125 percent of the equipment rating, and		—
	- are specially marked when specified (1.7.7).		—
3.3.5	Revise first column of Table 3E to "Smaller of the RATED CURRENT of the equipment or the PROTECTIVE CURRENT RATING of the circuit under consideration."		—
3.4.2	Motor control devices are provided for cord-connected equipment with a motor if the equipment is rated more than 12 A,	No motor.	N/A
	- or if the motor has a nominal voltage rating greater than 120 V		N/A
	- or is rated more than 1/3 hp (locked rotor current over 43 A)		N/A
3.4.8	Vertically-mounted disconnect switches and circuit breakers have the "on" position indicated by the handle in the up position.	No switch.	N/A
3.4.11	For computer room applications, equipment with battery systems capable of supplying 750 VA for five minutes have a battery disconnect means that may be connected to the computer room remote power-off circuit.	No such batteries in the equipment.	N/A
4.3.12	The maximum quantity of flammable liquid stored in equipment complies with NFPA 30.		N/A
4.3.13.5	Equipment with lasers meet the Canadian Radiation Emitting Devices Act, REDR C1370 and/or Code of Federal Regulations 21 CFR 1040, as applicable.	No laser.	N/A



IEC60950-1C ATTACHMENT			
Clause	Requirement + Test	Result - Remark	Verdict
4.7	For computer room applications, automated information storage systems with combustible media greater than 0.76 m ³ (27 cu ft) have a provision for connection of either automatic sprinklers or a gaseous agent extinguishing system with an extended discharge.	The equipment has no combustible area greater than 27 cubic feet.	N/A
4.7.3.1	For computer room applications, enclosures with combustible material measuring greater than 0.9 m ² (10 sq ft) or a single dimension greater than 1.8 m (6 ft) have a flame spread rating of 50 or less.	The equipment has no combustible material greater than 0.9m ² or single dimension greater than 1.8m.	N/A
	For other applications, enclosures with the same dimensions require a flame spread rating of 200 or less.		N/A
Annex H	Equipment that produces ionizing radiation comply with the Canadian Radiation Emitting Devices Act, REDR C1370 and/or Code of Federal Regulations, 21 CFR 1020, as applicable.	The equipment does not produce ionizing radiation.	N/A
Other National Differences			
1.5.1	Some components and materials associated with the risk of fire, electric shock, or personal injury have component or material ratings in accordance with the applicable national (Canadian and/or U.S.) component or material standard requirements.	Components are IEC or UL approved, see component list 1.5.1.	P
1.6.1.2	A circuit for connection to the DC Mains Supply is classified as either a SELV Circuit, TNV-2 Circuit or Hazardous Voltage Circuit depending on the maximum operating voltage of the supply.	Not for connection to DC mains supply.	N/A
	This maximum operating voltage includes consideration of the battery charging "float voltage" associated with the intended supply system, regardless of the marked power rating of the equipment.		N/A
2.3.1	For TNV-2 and TNV-3 circuits with other than ringing signals and with voltages exceeding 42.4 V _{peak} or 60 V _{d.c.} , the maximum acceptable current through a 2000 ohm resistor (or greater) connected across the voltage source with other loads disconnected is 7.1 mA peak or 30 mA d.c. under normal operating conditions.	No TNV circuitry.	N/A
2.3.2.1	In the event of a single fault between TNV and SELV circuits, the limits of 2.2.3 apply to SELV Circuits and accessible conductive parts.	No TNV circuitry.	N/A
2.6.3.4	Protective bonding conductors of non-standard protective bonding constructions (e.g., printed circuit traces) may be subjected to the additional limited short circuit test conditions specified.	No such part.	N/A
4.2.8.1	Enclosures around CRTs with a face diameter of 160 mm or more reduce the risk of injury due to the implosion of the CRT.	No CRT.	N/A

IEC60950-1C ATTACHMENT			
Clause	Requirement + Test	Result - Remark	Verdict
4.3.2	Equipment with handles complies with special loading tests.	No handle.	N/A
5.1.8.3	Equipment intended to receive telecommunication ringing signals comply with a special touch current measurement tests.	No TNV circuitry.	N/A
5.3.7	Internal (e.g., card cage) SELV circuit connectors and printed wiring board connectors that are accessible to the operator and that deliver power are overloaded.	No such parts.	N/A
	During abnormal operating testing, if a circuit is interrupted by the opening of a component, the test shall be repeated twice (three tests total) using new components as necessary		N/A
6.4	Equipment intended for connection to telecommunication network outside plant cable is protected against overvoltage from power line crosses in accordance with 6.4 and Annex NAC.	No TNV circuitry.	N/A
Annex EE	Articulated accessibility probe (Fig EE.3) is used for assessing accessibility to document/media shredders instead of the Figure 2A test finger.	Equipment is not a paper shredder.	N/A
M.2	Continuous ringing signals up to 16 mA only are permitted if the equipment is subjected to special installation and performance restrictions.	No TNV circuitry.	N/A
Annex NAD	Equipment connected to a telecommunication and cable distribution networks and supplied with an earphone intended to be held against, or in the ear comply with special acoustic pressure requirements.	No TNV circuitry.	N/A

IEC60950-1A ATTACHMENT			
Clause	Requirement + Test	Result - Remark	Verdict



<p align="center">ATTACHMENT TO TEST REPORT IEC 60950-1 CHINA NATIONAL DIFFERENCES</p> <p align="center">Information technology equipment Safety – Part 1: General requirements</p>			
Differences according to.....:	GB 4943.1--2011		
Attachment Form No.....:	CN_ND_IEC60950_1A		
Attachment Originator	CQC-TIRT		
Master Attachment	Date 2012-11		
Copyright © 2012 IEC System for Conformity Testing and Certification of Electrical Equipment (IECEE), Geneva, Switzerland. All rights reserved.			

China National Differences			
1.5.2	<p>Add a note behind the first dashed paragraph. Note: A component used shall comply with related requirements corresponding altitude of 5000m.</p> <p>CQC requirement clarification (September, 2012) : A component shall comply with the clearance requirements for altitudes up to 5000m. The requirement applies also for inner clearances / creepage distances.</p>	<2000m	N/A
1.7	<p>Add a paragraph before the last paragraph: The required marking and instruction should be given in normative Chinese unless otherwise specified.</p>	Must be considered before marketed in China.	P
1.7.1	<p>Amend dashed paragraph at the fifth paragraph : The RATED VOLTAGE should be 220V (single phase) or 380V (three-phases) for single rated voltage, for RATED VOLTAGE RANGE, it should cover 220V or 380V (three-phases), for multiple RATED VOLTAGES, one of them should be 220V or 380V (three-phases) and set on 220V or 380V (three-phases) when manufactured. And the RATED FREQUENCY or RATED FREQUENCY RANGE should be 50Hz or include 50Hz.</p>	Built-in equipment, and not directly connected to AC mains supply.	N/A

IEC60950-1A ATTACHMENT			
Clause	Requirement + Test	Result - Remark	Verdict
1.7.2.1	<p>Add requirements of warning for equipment intended to be used at altitude not exceeding 2000m or at non-tropical climate regions:</p> <p>For equipment intended to be used at altitude not exceeding 2000m, a warning label containing the following or a similar appropriate wording, or a symbol as in annex DD shall fixed to the equipment at readily visible place.</p> <p>"Only used at altitude not exceeding 2000m."</p>  <p>For equipment intended to be used in not-tropical climate regions, a warning label containing the following or a similar appropriate wording, or a symbol as in annex DD shall fixed to the equipment at readily visible place.</p> <p>"Only used in not-tropical climate regions."</p>  <p>If only the symbol used, the explanation of the symbol shall be contained in the instruction manual.</p> <p>The above statements shall be given in a language acceptable to the regions where the apparatus is intended to be used.</p>	<p><2000m. Must be considered before marketing in China.</p> <p>Tropical climate considered.</p>	<p>—</p> <p>N/A</p>
2.7.1	<p>Amended the first paragraph as:</p> <p>Protection in PRIMARY CIRCUITS against overcurrent short-circuits and earth faults shall be provided as an integral part of the equipment except special provisions. And the protective device shall meet the requirement of Clause 5.3.</p> <p>Delete note of Clause 2.7.1.</p> <p>CQC requirement clarification (September, 2012) :</p> <p>Except for Pluggable Equipment Type B and Permanently Connected Equipment shall the protective device be included as parts of the equipment.</p>	<p>No primary circuit in this built-in equipment.</p> <p>Circuits in the equipment considered as secondary circuits.</p>	N/A

IEC60950-1A ATTACHMENT			
Clause	Requirement + Test	Result - Remark	Verdict
2.9.2	<p>First section of Clause 2.9.2 amended as two sections:</p> <p>Where required by 2.9.1, 2.10.8.3, 2.10.10 or 2.10.11, humidity conditioning is conducted for 120 h in a cabinet or room containing air with ambient temperature $40\pm 2^{\circ}\text{C}$ and a relative humidity of $(93\pm 3)\%$. During this conditioning the component or subassembly is not energized.</p> <p>For equipment not to be operated at tropical climatic conditions, Where required by 2.9.1, 2.10.8.3, 2.10.10 or 2.10.11, humidity conditioning is conducted for 48 h in a cabinet or room containing air with a relative humidity of $(93\pm 3)\%$. The temperature of the air, at all places where samples can be located, is maintained within 2°C of any convenient value between 20°C and 30°C such that condensation does not occur.</p> <p>Due to pretreatment of equipment operated at high altitude area is humidity conditioning withstand hot shock, specific requirements are to be considered.</p> <p><i>CQC requirement clarification (September, 2012) : Ref. the following text above : "Due to pretreatment of equipment operated at high altitude area is humidity conditioning withstand hot shock, specific requirements are to be considered."</i></p> <p><i>These requirements are to be considered and are not covered by clause 2.9.2 of GB 4943.1-2011.</i></p> <p>Add note: For equipment to be operated at 2000 m - 5000m above sea level, assessment and requirement of humidity conditioning for Insulation material properties are considered.</p>	<p>Humidity treatment of equipment with:</p> <p>Relative humidity: 93%</p> <p>Temperature: 40°C</p> <p>Duration: 120h</p> <p><2000m</p>	P
2.10.3.1	<p>Amend the third paragraph of Clause 2.10.3.1 to be:</p> <p>These requirements apply for equipment to be operated up to 2000 m above sea level. For equipment to be operated at more than 2000 m above sea level and up to 5000m above sea level, the minimum CLEARANCE shall be multiplied by the factor 1.48 corresponding altitude of 5000m given in Table A.2 of IEC 60664-1. For equipment to be operated at more than 5000 m above sea level, the minimum CLEARANCE shall be multiplied by the factor given in Table A.2 of IEC 60664-1. Linear interpolation is permitted between the nearest two points in Table A.2. The calculated minimum CLEARANCE using this multiplication factor shall be rounded up to the next higher 0,1 mm increment.</p>	<2000m	N/A

IEC60950-1A ATTACHMENT			
Clause	Requirement + Test	Result - Remark	Verdict
2.10.3.3& 2.10.3.4	Add "(applicable for altitude up to 2000m)" in header of Table 2K、 2L and 2M.	Considered.	P
2.10.3.4	<p>Add a new section above Table 2K and in Clause 2.10.3.4:</p> <p>Minimum CLEARANCES determined by above rules apply for equipment to be operated up to 2000m above sea level. For equipment operated at 2000 m - 5000m above sea level, the minimum CLEARANCE shall be multiplied by the factor 1.48 corresponding altitude of 5000m given in Table A.2 of GB/T16935.1 (IEC 60664-1) . For equipment to be operated at more than 5000 m above sea level, the minimum CLEARANCE shall be multiplied by the factor given in Table A.2 of GB/T16935.1.</p> <p>CQC requirement clarification (September, 2012) :</p> <p>Misprint of above reference "Table 2K". The reference shall be "Table 2M".</p>	<2000m	N/A
3.2.1.1	Add a paragraph before the last paragraph: Plugs connected to AC mains supply shall comply with GB 1002 or GB 1003 or GB/T 11918 as applicable.	Built-in equipment, and not directly connected to AC mains supply.	—
4.2.8	Clause 4.2.8 cathode ray tubes quoted Clause 18 of GB8898-2011. Delete note of Clause 4.2.8.	No CRT.	N/A
Annex E	<p>Amend last section:</p> <p>For comparison of winding temperatures determined by the resistance method of this annex with the temperature limits of Table 4B, 35 °C shall be added to the calculated temperature rise.</p> <p>Add note: for equipment not to be operated at tropical climatic conditions, 25 °C shall be added to the calculated temperature rise to compare with the temperature of Table 4B.</p>	Thermocouple method of winding temperature used.	N/A

IEC60950-1A ATTACHMENT			
Clause	Requirement + Test	Result - Remark	Verdict
Annex G.6	Change the second section of Clause G.6 to be: For equipment to be operated at 2000 m - 5000m above sea level, the minimum CLEARANCE shall be multiplied by the factor 1.48 corresponding altitude of 5000m given in Table A.2 of GB/T16935.1. For equipment to be operated at more than 5000 m above sea level, the minimum CLEARANCE shall be multiplied by the factor given in Table A.2 of IEC 60664-1. Linear interpolation is permitted between the nearest two points in Table A.2. The calculated minimum CLEARANCE using this multiplication factor shall be rounded up to the next higher 0,1 mm increment.	<2000m	N/A
Annex DD (normative)	Added annex DD: Instructions for the new safety warning labels.  DD.1 Altitude warning label Meaning of the label: Evaluation for apparatus only based on altitude not exceeding 2000m, therefore it's the only operating condition applied for the equipment .There may be some potential safety hazard if the equipment is used at altitude above 2000m.	Considered.	—
	 DD.2 Climate warning label Meaning of the label: Evaluation for apparatus only based on temperate climate condition, therefore it's the only operating condition applied for the equipment .There may be some potential safety hazard if the equipment is used in tropical climate region.	Tropical climate considered.	N/A
Annex EE (informative)	Added annex EE: Illustration relative to safety explanation in normative Chinese、Tibetan、Mongolian、Zhuang Language and Uighur.	Must be considered before marketing in China.	—

	<i>Special national conditions</i>		P
1.1.2	GB4943.1-2011 applies to equipment used at altitudes not exceeding 5000m above sea level, primarily in regions with moderate or tropical climates. Revise the third dashed paragraph of 1.1.2 as: ——equipment intended to be used in vehicles, on board ships or aircraft, at altitudes greater than 5000m;	Considered.	P

IEC60950-1A ATTACHMENT			
Clause	Requirement + Test	Result - Remark	Verdict
	CQC requirement clarification (September, 2012) : The Chinese standard (GB 4943.1-2011) sets requirements for altitudes up to 5000m.		
1.4.5	Amend the second paragraph by the following: If the equipment is intended for direct connection to an AC mains supply, the tolerances on RATED VOLTAGE shall be taken as +10% and -10%.	Equipment not directly connected to AC power distribution system.	N/A
1.4.12.1	Tma: The maximum ambient temperature permitted by the manufacturer's specification, or 35 °C, whichever is greater. Add note 1: For equipment not to be operated at tropical climatic conditions, Tma is the maximum ambient temperature permitted by the manufacturer's specification, or 25 °C, whichever is greater. Add note 2: For equipment to be operated at 2000m-5000m above sea level, its temperature test conditions and temperature limits are under consideration.	Equipment rated max. ambient temperature 65 °C. <2000m	P

SI 60950 Part 1 (2009)			
Clause	Requirement + Test	Result - Remark	Verdict

ATTACHMENT: NATIONAL DIFFERENCES – ISRAEL			
Test results according to Online CB BULLETIN (Last modified date of 2011-03-02)			
1.7	Marking and instructions The clause is applicable with the following additions: - Subclause 1.7.201 shall be added at the beginning of the clause as follows:		—
1.7.201	Marking in the Hebrew language The marking in the Hebrew language shall be in accordance with the Consumer Protection Order (Marking of goods), 1983. In addition to the marking required by clause 1.7.1, the following details shall be marked in the Hebrew language. The details shall be marked on the apparatus or on its package, or on a label properly attached to the apparatus or on the package, by bonding or sewing, in a manner that the label cannot be easily removed. 1. Name of the apparatus and its commercial designation; 2. Manufacturer's name and address. If the apparatus is imported, the importer's name and address; 3. Manufacturer's registered trademark, if any; 4. Name of the model and serial number, if any; 5. Country of manufacture.	Must be considered before marketed in Israel.	—
1.7.2	Safety instructions and Marking 1.7.2.1 General The following shall be added to the clause: All the instructions and warnings related to safety shall also be written in the Hebrew language.	Must be considered before marketed in Israel.	—
2.	Protection from Hazards The clause is applicable with the following additions:		—

SI 60950 Part 1 (2009)			
Clause	Requirement + Test	Result - Remark	Verdict
2.9.4	<p>Separation from hazardous voltages</p> <p>The following shall be added at the beginning of the clause :</p> <p>In Israel, according to the Electricity Law, 1954, and the Electricity Regulations (Earthing and means of protection against electricity of voltages up to 1,000V) 1991, seven means of protection against electrocution are permitted, as follows:</p> <p>1) TN-S - Network system earthing; TN-C-S - Network system earthing;</p> <p>2) TT - Network system earthing;</p> <p>3) IT - Network Insulation Terre;</p> <p>4) Isolated transformer;</p> <p>5) Safety extra low voltage (SELV or ELV) ;</p> <p>6) Residual current circuit breaker (30 ma =IΔ);</p> <p>7) Reinforced insulation; Double insulation (class II) <input type="checkbox"/>.</p> <p>Clause 2.201 shall be added at the end of the clause, as follows:</p>	<p>Built-in equipment, and not directly connect to AC mains supply.</p> <p>Compliance shall be evaluated with the end product.</p>	N/A
2.201	<p>Prevention of electromagnetic interference</p> <p>- Prior to carrying out the tests in accordance with the clauses of this Standard, the compliance of the apparatus with the relevant requirements specified in the appropriate part of the Standard series, SI 961, shall be checked.</p> <p>The apparatus shall meet the requirements in the appropriate part of the Standard series.</p> <p>SI 961.</p> <p>- If there are components in the apparatus for the prevention of electromagnetic interference, these components shall not reduce the safety level of the apparatus as required by this Standard.</p>	<p>Must be considered before marketed in Israel.</p>	—
3.	<p>Wiring, connections and supply</p> <p>The clause is applicable with the following additions:</p>		—
3.2	<p>Connection to a mains supply</p>		—
3.2.1	<p>Means of connection</p>		—
3.2.1.1	<p>Connection to an a.c. mains supply</p> <p>After the note, the following note shall be added:</p> <p>Note:</p> <p>In Israel, the feed plug shall comply with the requirements of Israel Standard 51 32 Part I.</p>	<p>Built-in equipment, and not directly connect to AC mains supply.</p> <p>Compliance shall be evaluated with the end product.</p>	N/A
3.2.1.2	<p>Connection to a d.c. mains supply</p> <p>At the end of the first paragraph, the following note shall be added:</p> <p>Note:</p> <p>At the time of issue of this Standard, there is no Israel Standard for connection accessories to d.c.</p>	<p>No connection to DC mains supply.</p>	N/A

SI 60950 Part 1 (2009)			
Clause	Requirement + Test	Result - Remark	Verdict

ANNEX P	Normative references		—	
	The annex is applicable with the following national deviations: - The following Israel Standards have been inserted in place of some of the International Standards specified in this annex of the Standard, as follows:			
	The referenced International Standard	The substituted Israel Standard		Comments
	IEC 60065: 2001	SI 250(A) - Safety requirements for mains operated electronic and related apparatus for household and similar general use		The Israel Standard, excluding national deviations in it, is identical to the Standard of the International Electrotechnical Commission, IEC 65:1985, including its amendments
	IEC 60227 (all parts)	SI 473, all parts - Cables, cords and insulated conductors for nominal voltage up to 1000 volt		-
	IEC 60309 (all parts)	SI 1109, all parts - Plugs, socket-outlets and couplers for industrial purposes		SI 1109, part I and part 2, excluding national deviations in them , are identical to the Standards of the International Electrotechnical Commission IEC 60309-1:1999 and IEC 60309-2:1999, respectively.
	IEC 60317 (all parts)	SI 1067 Part I – Self-fluxing enamelled(B) round copper wires with high mechanical properties		The Israel Standard is identical to the Standard of the International Electrotechnical Commission IEC 317-1 (1980)
		SI 1067 Part 2 – Self-fluxing enamelled(B) round copper wires		The Israel Standard is identical to the Standard of the International Electrotechnical Commission IEC 317-4 (1980)
		SI 1067 Part 3 - Self-fluxing enamelled ^(B) round copper wires with a temperature index of 180°		The Israel Standard is identical to the Standard of the International Electrotechnical Commission IEC 317-8 (1980)
	IEC 60320 (all parts)	SI 60320 Part 1 - Appliance couplers for household and similar general purposes: General requirements		The Israel Standard, excluding national deviations in it, is identical to the Standard of the International Electrotechnical Commission , IEC 60320-1 (2001)
		SI 60320 Part 2.1 - Appliance couplers for household and similar general purposes: Sewing machine couplers		The Israel Standard, excluding national deviations in it, is identical to the Standard of the International Electrotechnical Commission , IEC 60320-2.1 (2000)
	IEC 60320 (all parts)	SI 60320 Part 2.2 – Appliance couplers for household and similar general purposes: Interconnection couplers for household and similar equipment		The Israel Standard, excluding national deviations in it, is identical to the Standard of the International Electrotechnical Commission , IEC 60320-2.2 (1998)
		SI 60320 Part 2.3 - Appliance couplers for household and similar general purposes: Interconnection couplers for household and similar equipment Appliance coupler for household and similar general purposes: Appliance coupler with a degree of protection higher than IPX0		The Israel Standard, excluding national deviations in it, is identical to the Standard of the International Electrotechnical Commission , IEC 60320-2.3 (1998)

IEC60950-1 ATTACHMENT			
Clause	Requirement + Test	Result - Remark	Verdict

ATTACHMENT TO TEST REPORT IEC 60950-1 JAPAN NATIONAL DIFFERENCES Information technology equipment – Safety – Part 1: General requirements	
Differences according to	: J60950-1(H22)
Attachment Form No.	: JP_ND_IEC60950_1A
Attachment Originator	:
Master Attachment	: 2010-11
Copyright © 2010 IEC System for Conformity Testing and Certification of Electrical Equipment (IECEE), Geneva, Switzerland. All rights reserved.	

1.2.4.1	Add the following new NOTE. NOTE Even if the equipment is designed as Class I, the equipment is regarded as Class 0I equipment when a 2-pin adaptor with an earthing lead wire or a cord set having a 2-pin plug with an earthing lead wire is provided or recommended.	Built-in equipment. Compliance shall be evaluated with the end product.	N/A
1.2.4.3A	Add the following new clause. 1.2.4.3A CLASS 0I EQUIPMENT Equipment having attachment plug without earthing blade, where protection against electric shock is achieved by: <ul style="list-style-type: none"> - using BASIC INSULATION, and - providing externally an earth terminal or a lead wire for earthing in order to connect those conductive parts that might assume a HAZARDOUS VOLTAGES in the event of BASIC INSULATION fault to the PROTECTIVE EARTHING CONDUCTOR in the building wiring. NOTE Class 0I equipment may have a part constructed with Double Insulation or Reinforced Insulation. circuit.	Built-in equipment. Compliance shall be evaluated with the end product.	N/A

IEC60950-1 ATTACHMENT			
Clause	Requirement + Test	Result - Remark	Verdict
1.3.2	<p>Add the following notes after the first paragraph:</p> <p>NOTE 1 Transportable or similar equipment that is relocated frequently for intended usage should not be designed as Class I or Class 0I equipment unless it is intended to be installed by service personnel.</p> <p>NOTE 2 Considering wiring circumstance in Japan, equipment intended to be installed where the provision for earthing connection is unlikely should not be designed as Class I or Class 0I equipment unless it is intended to be installed by service personnel.</p>		N/A
1.5.1	<p>Replace the first paragraph with the following:</p> <p>Where safety is involved, components shall comply either with the requirements of this standard or with the safety aspects of the relevant JIS component standard or IEC component standards in case there is no applicable JIS component standard is available. However, in case a component that falls within the scope of the METI Ministerial ordinance (No. 85:1962) is properly used in accordance with its marked ratings, the requirements of 1.5.4, 2.8.7 and 3.2.5 apply, and in addition, a cord connector of power supply cord set matching with an appliance inlet specified in the standard sheets of IEC 60320-1, shall comply with relevant standard sheet of IEC 60320-1.</p> <p>Replace NOTE 1 with the following:</p> <p>NOTE 1 A JIS or an IEC component standard is considered relevant only if the component in question clearly falls within its scope.</p>	Considered.	P

IEC60950-1 ATTACHMENT			
Clause	Requirement + Test	Result - Remark	Verdict
1.5.2	<p>Replace the first sentence in the first dashed paragraph with the following:</p> <ul style="list-style-type: none"> - a component that has been demonstrated to comply with a JIS component standard harmonized with the relevant IEC component standard, or where such JIS component standard is not available, a component that has been demonstrated to comply with the relevant IEC component standard shall be checked for correct application and use in accordance with its rating. <p>Add a NOTE after the first dashed paragraph as follows:</p> <p>NOTE 1 See 1.7.5A when Type C.14 appliance coupler rated 10 A per IEC 60320-1 is used with an equipment rated not more than 125 V and rated more than 10 A.</p> <p>Replace the first sentence in the third dashed paragraph as follows:</p> <ul style="list-style-type: none"> - where no relevant IEC component standard or JIS component standard harmonized with the relevant IEC component standard exists, or where components are used in circuits not in accordance with their specified rating, the components shall be tested under the conditions occurring in the equipment. 	Considered.	P
1.5.6	In this sub-clause, add "JIS C 5101-14:1998 or" before the reference number, IEC 60384-14:1993.		N/A
1.5.7.2	In this sub-clause, add "JIS C 5101-14:1998 or" before the reference number, IEC 60384-14:1993.	No such component in the equipment .	N/A
1.5.8	In the first paragraph, add "JIS C 5101-14:1998 or" before the reference number, IEC 60384-14:1993.		N/A
1.7.1	<p>Replace the fifth dashed paragraph with the following:</p> <ul style="list-style-type: none"> - manufacturer's or responsible company's name or trade-mark or identification mark; 	Considered.	P

IEC60950-1 ATTACHMENT			
Clause	Requirement + Test	Result - Remark	Verdict
1.7.5	In the second paragraph, add “or JIS C 8303:2007” after the reference number, IEC/TR 60083:1997”.	No standard power outlet.	N/A
1.7.5A	Add the following new clause after 1.7.5 1.7.5A Appliance Couplers If an appliance coupler according to IEC 60320-1, C.14(rated current: 10 A) is used in equipment whose rated voltage is less than 125 V and the rated current is over 10 A, the following instruction or equivalent shall be described in the user instruction. “ Use only designated cord set attached in this equipment”	The rated current of equipment is less than 10A.	N/A
1.7.12	Replace first sentence with the following: Instructions and equipment marking related to safety shall be in Japanese.	Must be considered before marketed in Japan.	—
1.7.17A	Add the following new clause after 1.7.17 1.7.17A Marking for CLASS 0I EQUIPMENT For CLASS 0I EQUIPMENT, the following instruction shall be marked on the visible place of the mains plug or the main body: 必ず接地接続を行って下さい “Provide an earthing connection” Moreover, for CLASS 0I EQUIPMENT, the following or equivalent instruction shall be indicated on the visible place of the main body or written in the operating instructions: 接地接続は必ず、電源プラグを電源につなぐ前に行って下さい。又、接地接続を外す場合は、必ず電源プラグを電源から切り離してから行って下さい。 “Provide an earthing connection before the mains plug is connected to the mains. And, when disconnecting the earthing connection, be sure to disconnect after pulling out the mains plug from the mains.”	Built-in equipment. Compliance shall be evaluated with the end product.	N/A
2.1.1.1	In item b) of this sub-clause, replace “IEC 60083” with “JIS C 8303:2007 or Article 1 of the Ministerial Ordinance (No. 85:1962)”	Considered.	P

IEC60950-1 ATTACHMENT			
Clause	Requirement + Test	Result - Remark	Verdict
2.6.3.2	<p>Add the following after the first paragraph.</p> <p>This also applies to the conductor of lead wire for protective earthing of CLASS 0I EQUIPMENT.</p>	Built-in equipment. Compliance shall be evaluated with the end product.	N/A
2.6.4.2	<p>Replace the first paragraph with the following.</p> <p>Equipment required to have protective earthing shall have a main protective earthing terminal. For equipment with a DETACHABLE POWER SUPPLY CORD, the earthing terminal in the appliance inlet is regarded as the main protective earthing terminal except for CLASS 0I EQUIPMENT providing separate main protective earthing terminal other than appliance inlet.</p>	Input terminal block provided. Compliance shall be evaluated with the end product.	N/A
2.6.5.4	<p>Replace the first sentence with the following.</p> <p>Protective earthing connections of CLASS I EQUIPMENT shall make earlier and break later than the supply connections in each of the following:</p>	Input terminal block provided. Compliance shall be evaluated with the end product.	N/A
2.6.5.8A	<p>Add the following new clause after 2.6.5.8</p> <p>2.6.5.8A Earthing of CLASS 0I EQUIPMENT Plugs with a lead wire for earthing shall not be used for equipment having a rated voltage exceeding 150 V.</p> <p style="text-align: center;">For plugs with a lead wire for earthing, the lead wire shall not be earthed by a clip.</p> <p>CLASS 0I EQUIPMENT shall be provided with an earthing terminal or a lead wire for earthing in the external location where easily visible.</p>	Built-in equipment. Compliance shall be evaluated with the end product.	N/A
2.10.3.1	In this sub-clause, replace IEC 60664-1 with JIS C 0664:2003.	Considered.	P
2.10.3.2	In the second paragraph, replace IEC 60664-1 with JIS C 0664:2003.	Considered.	P
3.2.3	<p>Add the following after Table 3A:</p> <p>Table 3A applies when cables complying with JIS C 3662 or JIS C 3663 are used. In case of other cables, the cable entries shall be so designed that a conduit suitable for the cable used can be fitted.</p>	Built-in equipment, must be considered in the product.	—

IEC60950-1 ATTACHMENT			
Clause	Requirement + Test	Result - Remark	Verdict
3.2.5.1	<p>Add the following to the last of first dashed paragraph.</p> <p>Or mains cords shall be of the sheathed type complying with Appendix 1 of Article 1 of the Ministerial Ordinance (No. 85:1962) on stipulating technical requirements for the Electrical Appliance.</p> <p>Add the following to the last of second dashed paragraph.</p> <p>Or mains cords shall be of the sheathed type complying with Appendix 1 of Article 1 of the Ministerial Ordinance (No. 85:1962) on stipulating technical requirements for the Electrical Appliance.</p> <p>Delete 1) in Table 3B.</p>	Built-in equipment, must be considered in the product.	—
3.3.4	<p>Add the following note to Table 3D:</p> <p>NOTE For cables other than those complying with JIS C 3662 or JIS C 3663, terminals shall be suitable for the size of the intended cables.</p>	Built-in equipment, must be considered in the product.	—
3.3.7	<p>Add the following after the first sentence:</p> <p>This requirement is not applicable to the external earthing terminal of Class 0I equipment.</p>	Built-in equipment. Compliance shall be evaluated with the end product.	N/A
4.3.4	<p>Add the following after the first sentence:</p> <p>This requirement also applies to those connections in Class 0I equipment, where CLEARANCE or CREEPAGE DISTANCES over BASIC INSULATION would be reduced to less than the values specified in 2.10.</p>	Built-in equipment. Compliance shall be evaluated with the end product.	N/A
4.3.13.5	<p>Replace the first paragraph with the following:</p> <p>Except as permitted below, equipment shall be classified and labelled according to JIS C 6802:2005, and JIS C 6803:2006 or IEC 60825-2:2000, as applicable.</p> <p>Replace IEC 60825-1 in the second and the last paragraph with JIS C 6802:2005.</p>	No laser in the equipment.	N/A

IEC60950-1 ATTACHMENT																																			
Clause	Requirement + Test	Result - Remark	Verdict																																
4.5	<p>Add the following NOTE to Table 4B, 3):</p> <p>NOTE: In case no data for the material is available, Appendix 4, 4. (1). b. 3 of the Interpretation on the Ministerial Ordinance stipulating Technical Specifications for Electrical Appliances (Commerce and Distribution Policy Group No. 3:2008/06/19) may apply.</p>		N/A																																
5.1.3	<p>Add a note after the first paragraph as follows:</p> <p>NOTE Attention should be drawn to that majority of three-phase power system in Japan is of delta connection, and therefore, in that case, the test is conducted using the test circuit from IEC 60990, figure 13.</p>	Single-phase only.	N/A																																
5.1.6	<p>Replace Table 5A as follows:</p> <table border="1" data-bbox="424 972 1337 1809"> <thead> <tr> <th>Type of equipment</th> <th>Terminal A of measuring instrument connected to:</th> <th>Maximum TOUCH CURRENT mA r.m.s. ¹⁾</th> <th>Maximum PROTECTIVE CONDUCTOR CURRENT</th> </tr> </thead> <tbody> <tr> <td>All equipment</td> <td>Accessible parts and circuits not connected to protective earth</td> <td>0,25</td> <td>-</td> </tr> <tr> <td>HAND-HELD</td> <td rowspan="4">Equipment main protective earthing terminal (if any) CLASS I EQUIPMENT</td> <td>0,75</td> <td>-</td> </tr> <tr> <td>MOVABLE (other than HAND-HELD, but including TRANSPORTABLE EQUIPMENT</td> <td>3,5</td> <td>-</td> </tr> <tr> <td>STATIONARY, PLUGGABLE TYPE A</td> <td>3,5</td> <td>-</td> </tr> <tr> <td>All other STATIONARY EQUIPMENT - not subject to the conditions of 5.1.7 - subject to the conditions of 5.1.7</td> <td>3,5 -</td> <td>- 5 % of input current</td> </tr> <tr> <td>HAND-HELD</td> <td rowspan="2">Equipment main protective earthing terminal (if any) CLASS 0I EQUIPMENT</td> <td>0,5</td> <td>-</td> </tr> <tr> <td>Others</td> <td>1,0</td> <td>-</td> </tr> <tr> <td colspan="4">¹⁾ If peak values of TOUCH-CURRENT are measured, the maximum values obtained by multiplying the r.m.s. values by 1,414.</td> </tr> </tbody> </table>	Type of equipment	Terminal A of measuring instrument connected to:	Maximum TOUCH CURRENT mA r.m.s. ¹⁾	Maximum PROTECTIVE CONDUCTOR CURRENT	All equipment	Accessible parts and circuits not connected to protective earth	0,25	-	HAND-HELD	Equipment main protective earthing terminal (if any) CLASS I EQUIPMENT	0,75	-	MOVABLE (other than HAND-HELD, but including TRANSPORTABLE EQUIPMENT	3,5	-	STATIONARY, PLUGGABLE TYPE A	3,5	-	All other STATIONARY EQUIPMENT - not subject to the conditions of 5.1.7 - subject to the conditions of 5.1.7	3,5 -	- 5 % of input current	HAND-HELD	Equipment main protective earthing terminal (if any) CLASS 0I EQUIPMENT	0,5	-	Others	1,0	-	¹⁾ If peak values of TOUCH-CURRENT are measured, the maximum values obtained by multiplying the r.m.s. values by 1,414.					N/A
Type of equipment	Terminal A of measuring instrument connected to:	Maximum TOUCH CURRENT mA r.m.s. ¹⁾	Maximum PROTECTIVE CONDUCTOR CURRENT																																
All equipment	Accessible parts and circuits not connected to protective earth	0,25	-																																
HAND-HELD	Equipment main protective earthing terminal (if any) CLASS I EQUIPMENT	0,75	-																																
MOVABLE (other than HAND-HELD, but including TRANSPORTABLE EQUIPMENT		3,5	-																																
STATIONARY, PLUGGABLE TYPE A		3,5	-																																
All other STATIONARY EQUIPMENT - not subject to the conditions of 5.1.7 - subject to the conditions of 5.1.7		3,5 -	- 5 % of input current																																
HAND-HELD	Equipment main protective earthing terminal (if any) CLASS 0I EQUIPMENT	0,5	-																																
Others		1,0	-																																
¹⁾ If peak values of TOUCH-CURRENT are measured, the maximum values obtained by multiplying the r.m.s. values by 1,414.																																			
6	Replace IEC 60664-1 in NOTE 4 with JIS C 0664.	No TNV circuit.	N/A																																
7	Replace IEC 60664-1 in NOTE 3 with JIS C 0664:2003.	Not cable distribution system.	N/A																																

IEC60950-1 ATTACHMENT			
Clause	Requirement + Test	Result - Remark	Verdict
7.2	<p>Add the following after the paragraph:</p> <p>However, the separation requirements and tests of 6.2.1 a), b) and c) do not apply to a CABLE DISTRIBUTION SYSTEM if all of the following apply:</p> <ul style="list-style-type: none"> - the circuit under consideration is a TNV-1 CIRCUIT; and - the common or earthed side of the circuit is connected to the screen of the coaxial cable and to all accessible parts and circuits (SELV, accessible metal parts and LIMITED CURRENT CIRCUITS, if any); and - the screen of the coaxial cable is intended to be connected to earth in the building installation. 		N/A
W.1	<p>Replace the second and the third sentence in the first paragraph with the following:</p> <p>This distinction between earthed and unearthed (floating) circuit is not the same as between CLASS I EQUIPMENT, CLASS 0I EQUIPMENT and CLASS II EQUIPMENT. Floating circuits can exist in CLASS I EQUIPMENT or CLASS 0I EQUIPMENT and earthed circuits in CLASS II EQUIPMENT.</p>		N/A

IEC60950-1 ATTACHMENT			
Clause	Requirement + Test	Result - Remark	Verdict
Annex JA	<p>Add a new annex JA with the following contents.</p> <p style="text-align: center;">Annex JA (normative)</p> <p style="text-align: center;">Document shredding machines</p> <p>Document shredding machines shall also comply with the requirements of this annex except those of STATIONARY EQUIPMENT used by connecting directly to an AC MAINS SUPPLY of three-phase 200V or more.</p> <p>JA.1 Markings and instructions</p> <p>The symbol</p>  <p>(JIS S 0101:2000, 6.2.4) and the following precautions for use shall be marked on readily visible part adjacent to document feed opening. The marking shall be clearly legible, permanent, and easily discernible;</p> <ul style="list-style-type: none"> - that use by an infants/children may cause a hazard of injury etc.; - that a hand can be drawn into the mechanical section for shredding when touching the document-slot; - that clothing can be drawn into the mechanical section for shredding when touching the document-slot; - that hairs can be drawn into the mechanical section for shredding when touching the document-slot; - in case of equipment incorporating a commutator motor, that equipment may catch fire or explode by spraying of flammable gas. <p>JA.2 Inadvertent reactivation</p> <p>Any safety interlock that can be operated by means of the test finger, Figure JA.1, is considered to be likely to cause inadvertent reactivation of the hazard.</p> <p>Compliance is checked by inspection and, where necessary, by a test with the test finger, Figure JA.1</p> <p>JA.3 Disconnection from the mains supply</p> <p>Document shredding machines shall incorporate an isolating switch complying with sub-clause 3.4.2 as the device disconnecting the power of hazardous moving parts. For this switch, two-position (single-use) switch or multi-position (multifunction) switch (e.g., slide switch) may be used.</p>	Not such equipment.	N/A

IEC60950-1 ATTACHMENT			
Clause	Requirement + Test	Result - Remark	Verdict
Annex JA	<p>If two-position switch, the positions for "ON" and "OFF" shall be indicated in accordance with sub-clause 1.7.8. If multi-position switch, the position for "OFF" shall be indicated in accordance with sub-clause 1.7.8 and other positions shall be indicated with proper terms or symbols.</p> <p>Compliance is checked by inspection</p> <p>JA.4 Protection against hazardous moving parts</p> <p>Any warning shall not be used instead of the structure for preventing access to hazardous moving parts.</p> <p style="padding-left: 40px;">Document shredding machines shall comply with the following requirements.</p> <p>Insert the test finger, Figure JA.1, into all openings in MECHANICAL ENCLOSURES without applying appreciable force. It shall not be possible to touch hazardous moving parts with the test finger. This consideration applies to all sides of MECHANICAL ENCLOSURES when the equipment is mounted as intended. Before testing with the test finger, remove the parts detachable without a tool.</p> <p>Insert the wedge-probe, Figure JA.2, into the document-slot. And, against all directions of openings, if straight-cutting type, a force of 45 N shall apply to the probe, and 90 N if cross-cutting type. In this case, the weight of the probe is to be factored into the overall applied force. Before testing with the wedge-probe, remove the parts detachable without a tool. It shall not be possible to touch any hazardous moving parts, including the shredding roller or the mechanical section for shedding, with the probe.</p>		N/A

IEC60950-1 ATTACHMENT

Clause	Requirement + Test	Result - Remark	Verdict
--------	--------------------	-----------------	---------

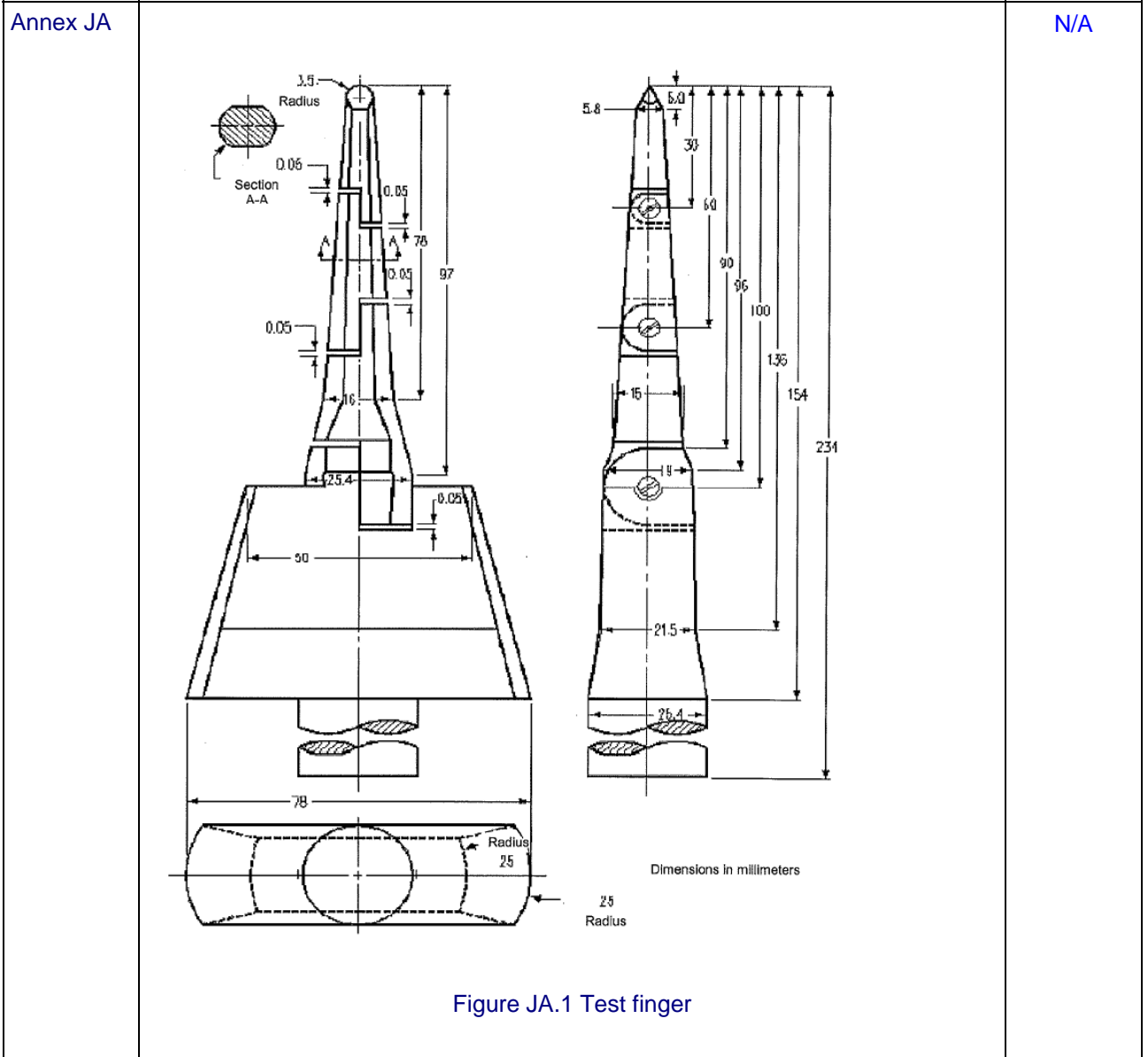
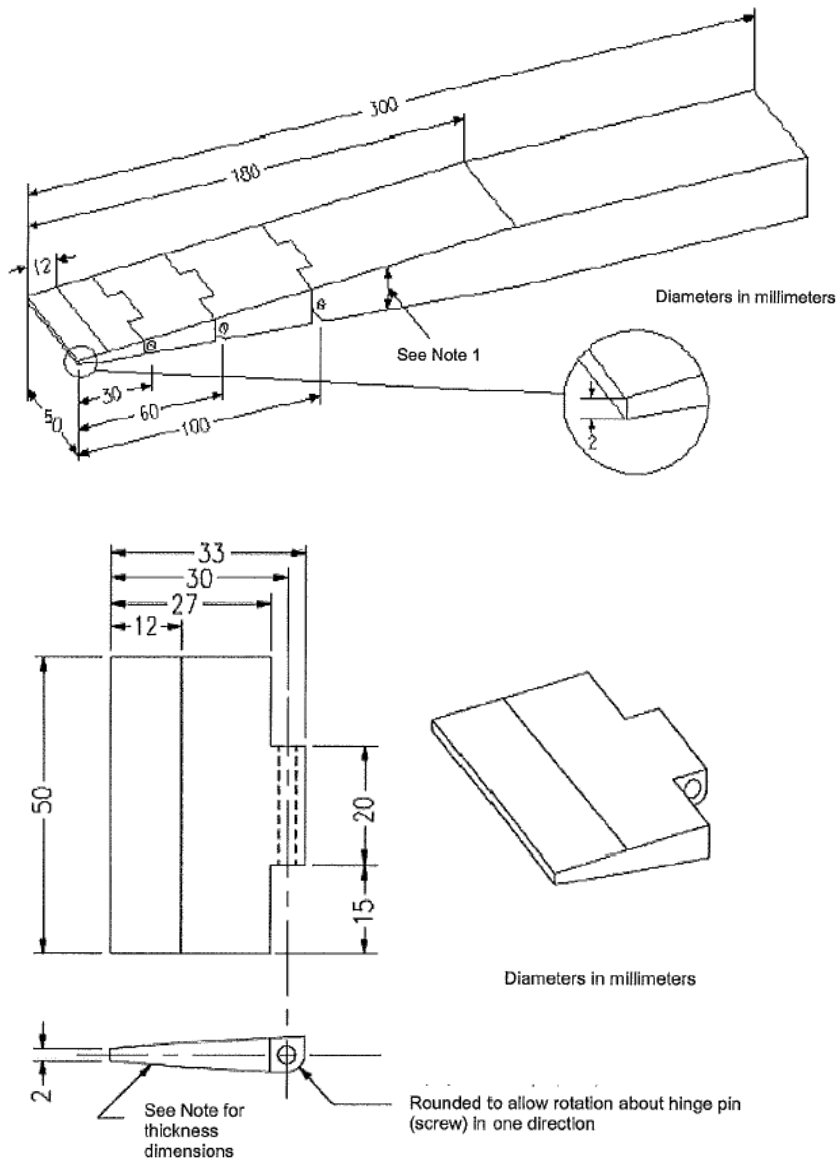

Figure JA.1 Test finger

IEC60950-1 ATTACHMENT			
Clause	Requirement + Test	Result - Remark	Verdict

Annex JA

N/A



Details of the tip of wedge

Distance from the tip (mm)	Thickness of probe (mm)
0	2
12	4
180	24

NOTE 1 The thickness of the probe varies linearly, with slope changes at the respective points shown in the table.

NOTE2 The allowable dimensional tolerance of the probe is +/- 0.127 mm.

Figure JA.2 Wedge-probe

IEC60950-1C ATTACHMENT			
Clause	Requirement + Test	Result - Remark	Verdict

<p align="center">ATTACHMENT TO TEST REPORT IEC 60950-1</p> <p align="center">KOREAN NATIONAL DIFFERENCES</p>			
Differences according to.....: K 60950-1			
IEC Standard : 60950-1(ed.2);am1			
Last Modification.....: Date (2012-05-31)			
Clause	Requirement + Test	Result - Remark	Verdict
1.5.101	Plugs for the connection of the apparatus to the supply mains shall comply with the Korean requirement (KSC 8305).	Built-in equipment, must be considered in the end product.	—
8	EMC The apparatus shall comply with the relevant CISPR standards.	Must be considered before marketing in Korea.	—

IEC60950-1 ATTACHMENT			
Clause	Requirement + Test	Result - Remark	Verdict

ATTACHMENT TO TEST REPORT IEC 60950-1 Singapore DIFFERENCES

Differences according to.....: Singapore: Consumer Protection Information Booklet, 2012 Edition, (Ver. 4.3).

IEC Standard 60950-1(ed.1)

Last Modification.....: Date (2012-11-29)

No	Item	Requirement + Test	Result - Remark	Verdict
----	------	--------------------	-----------------	---------

The following is the national differences in accordance with safety authority website www.spring.gov.sg, ref. Singapore Consumer Protection (Safety Requirements) - Information booklet - chapter 7 (page 21 - 24). Based on information by Singapore NCB – PSB Corp.

7 SAFETY AUTHORITY'S REQUIREMENTS

The Safety Authority monitors the safety of the controlled goods sold in Singapore by investigating all complaints, incidents and accidents reported to the authority. Experiences gained are translated into the Safety Authority's Requirements. These requirements are to be fulfilled in addition to the applicable safety standards.

Applicable to all products

1	Test certificate / Test report	Test certificate / Test report more than three (3) years old shall be rejected.	Compliance must be considered when equipment marketed Singapore.	—
2	Controlled Goods incorporated with additional function	The additional function must be tested to its applicable safety standard.		P

Applicable to all electrical products

3	All appliances	All appliances must be tested to 230 VAC.	Built-in equipment, and not connected to AC mains sully directly. Compliance shall be evaluated with the end product.	N/A
4	Voltage selector (voltage mismatch test)	Appliance fitted with voltage selector shall be tested as follows: Connect appliance to 230 VAC mains with voltage selector switch to settings not suitable for operation at 230 VAC.	No voltage selector.	N/A
5	Tropical condition test	All appliances (with tropical test requirements in applicable Standards) shall comply with the tropical condition test as stated in the relevant IEC Standards.	Complied with requirement, refer to main test report.	P

IEC60950-1 ATTACHMENT				
Clause	Requirement + Test	Result - Remark	Verdict	
6	Class I appliances (3-pin mains plug)	All Class I appliances must be fitted with 3-pin mains plugs complied with SS 145/SS 472 that are registered with the Safety Authority.	Class II equipment.	N/A
7	Class II appliances (mains plug)	a) All Class II appliances must be fitted with 2-pin mains plug (Appendix W) complied with IEC 83: 1975 (Standard C5, Version II) or EN 50075: 1991. b) Class II appliances that are fitted with 3-pin mains plugs must use plugs that are complied with SS 145 and registered with the Safety Authority.	Built-in equipment, and not connected to AC mains sully directly. Compliance shall be evaluated with the end product.	—
8	Appliances rated ≥ 3 kW or connected to fixed wiring	Electric appliance ≥ 3 kW must be connected to fixed wiring. All connection to fixed wiring must be in accordance with Code of Practice CP5.	The rated power is less than 3kW.	N/A
9	Detachable power cord set (consists of mains plug, mains cord and appliance connector)	Detachable power cord set must be listed in the test report critical component list.	Built-in equipment, and not connected to AC mains sully directly. Compliance shall be evaluated with the end product.	—
10	Circuit diagrams	Circuit diagrams must be indicated with component's values for products tested to IEC 60065 and IEC 60950.	Must be evaluated when market to Singapore	—
11	Circuit diagrams of electronic modules in electrical appliances	Circuit diagrams of the electronic modules in the electrical appliances must be provided.	No such parts.	N/A
12	Controlled goods likely to be treated as toy by children	Controlled goods, having an enclosure, which is shaped and decorated so that it is likely to be treated as a toy by children, shall not be accepted for certification and registration.	The equipment is not treated as toy by children.	N/A
Applicable to AC adaptor				
14	3-pin AC adaptor (Appendix V)	Test report showing that the 3-pin complied with sub-clauses 12.1 & 12.3 of SS 246 must be submitted.	Built-in equipment, and not connected to AC mains sully directly. Compliance shall be evaluated with the end product.	—

IEC60950-1 ATTACHMENT				
Clause	Requirement + Test	Result - Remark	Verdict	
15	2-pin AC adaptor (Appendix V)	The 2-pin (Appendix T) shall comply with EN 50075	Built-in equipment, and not connected to AC mains sully directly. Compliance shall be evaluated with the end product.	—
16	Detachable power supply cord set not supplied by Registered Supplier	Registered Supplier who is not supplying the detachable power supply cord set together with the AC Adaptor must provide written instruction to its customer on the type of approved detachable power cord set to use.	Built-in equipment, and not connected to AC mains sully directly. Compliance shall be evaluated with the end product.	—
Applicable to computer products				
17	CD/DVD ROM (used in personal computer)	Test certificate showing that CD/DVD ROM has complied with IEC 825 must be provided.	The equipment does not consist of CD/DVD ROM.	N/A
18	Modem Card (used in personal computer)	Modem card incorporated in the personal computer must be tested at set level (sub-clauses 5.1 & 6 of IEC 60950) or at component level.	The equipment does not consist of Modem Card.	N/A
Applicable to plasma/LCD display monitor				
38	Plasma/LCD display monitor with TV tuner	Plasma/LCD display monitor tested to IEC 60950 would require additional test to clauses 9 (related to antenna only), 10.1, 10.2, 10.3 and 12.5 of IEC 60065.	No TV tuner provided.	N/A

IEC60950-1C ATTACHMENT			
Clause	Requirement + Test	Result - Remark	Verdict

ATTACHMENT TO TEST REPORT IEC 60950-1 U.S.A. NATIONAL DIFFERENCES Information technology equipment – Safety – Part 1: General requirements			
Differences according to.....: UL 60950-1-07			
Attachment Form No.: US_ND_IEC60950_1C			
Attachment Originator.....: TÜV SÜD Product Service GmbH			
Master Attachment.....: Date (2012-08)			
Copyright © 2012 IEC System for Conformity Testing and Certification of Electrical Equipment (IECEE), Geneva, Switzerland. All rights reserved.			

	Special national conditions		
1.1.1	All equipment is to be designed to allow installation in accordance with the National Electrical Code (NEC), ANSI/NFPA 70, the Canadian Electrical Code (CEC), Part I, CAN/CSA C22.1, and when applicable, the National Electrical Safety Code, IEEE C2.	Built-in equipment, and not connected to AC mains sully directly. Compliance shall be evaluated with the end product.	—
	Also, unless marked or otherwise identified, installation is allowed per the Standard for the Protection of Electronic Computer/Data-Processing Equipment, ANSI/NFPA 75.		—
1.4.14	For Pluggable Equipment Type A, the protection in the installation is assumed to be 20A.	Built-in equipment, and not connected to AC mains sully directly.	N/A
1.5.5	For lengths exceeding 3.05 m, external interconnecting flexible cord and cable assemblies are required to be a suitable cable type (e.g., DP, CL2) specified in the CEC/NEC.	Built-in equipment, and not connected to AC mains sully directly. Compliance shall be evaluated with the end product.	—
	For lengths 3.05 m or less, external interconnecting flexible cord and cable assemblies that are not types specified in the CEC are required to have special construction features and identification markings.		—
1.7.1	Equipment for use on a.c. mains supply systems with a neutral and more than one phase conductor (e.g. 120/240 V, 3-wire) require a special marking format for electrical ratings.	Built-in equipment, and not connected to AC mains sully directly.	N/A

IEC60950-1C ATTACHMENT			
Clause	Requirement + Test	Result - Remark	Verdict
	A voltage rating that exceeds an attachment plug cap rating is only permitted if it does not exceed the extreme operating conditions in Table 2 of CAN/CSA C22.2 No. 235, and		N/A
	- if it is part of a range that extends into the Table 2 "Normal Operating Conditions."		N/A
	A voltage rating is not to be lower than the specified "Normal Operating Conditions," unless it is part of a range that extends into the "Normal Operating Conditions."		N/A
1.7.7	Wiring terminals intended to supply Class 2 outputs in accordance with CEC Part 1 or NEC are marked with the voltage rating and "Class 2" or equivalent.		N/A
	- Marking is located adjacent to the terminals		N/A
	- Marking is visible during wiring		N/A
2.5	Fuse providing Class 2, Limited Power Source, or TNV current limiting is not operator-accessible unless it is not interchangeable.	No such fuse.	N/A
2.6.3.3	Modify first column on Table 2D to "Smaller of the RATED CURRENT of the equipment or the PROTECTIVE CURRENT RATING of the circuit under consideration."		N/A
2.7.1	Suitable NEC/CEC branch circuit protection rated at the maximum circuit rating is provided for all standard supply outlets and receptacles (such as supplied in power distribution units) if the supply branch circuit protection is not suitable.	No special external branch circuit overcurrent devices provided.	N/A
	Power distribution transformers distributing power at 100 volts or more, and rated 10 kVA or more, provided with special transformer overcurrent protection.	No such transformer.	N/A
3.2	Wiring methods (terminals, leads, etc.) used for the connection of the equipment to the mains is in accordance with the NEC/CEC.	Built-in equipment. Compliance shall be evaluated with the end product.	—
3.2.1	Attachment plugs of power supply cords are rated not less than 125 per cent of the rated current of the equipment.		N/A
3.2.1.2	Equipment connected to a centralized d.c. power system, and having one pole of the DC mains input terminal connected to the main protective earthing terminal in the equipment comply with special earthing, wiring, marking and installation instruction requirements.	No connection to DC mains supply.	N/A
3.2.3	Permanent connection of equipment to the mains supply by a power supply cord is not permitted, except for certain equipment, such as ATMs.	The equipment is not permanently connected to the mains.	N/A

IEC60950-1C ATTACHMENT			
Clause	Requirement + Test	Result - Remark	Verdict
3.2.5	Power supply cords are no longer than 4.5 m in length.	Built-in equipment, must considered in end product.	—
	Minimum cord length is 1.5 m, with certain constructions such as external power supplies allowed to consider both input and output cord lengths into the requirement.		—
	Flexible power supply cords are compatible with Article 400 of the NEC, and Tables 11 and 12 of the CEC.		—
3.2.9	Permanently connected equipment have a suitable wiring compartment and wire bending space.	The equipment is not permanently connected to the mains.	N/A
3.3	Wiring terminals and associated spacings for field wiring connections comply with CSA C22.2 No. 0.	Built-in equipment. Compliance shall be evaluated with the end product.	—
3.3.3	Wire binding screws are not permitted to attach conductors larger than 10 AWG (5.3 mm ²).		—
3.3.4	Terminals for permanent wiring, including protective earthing terminals, are suitable for Canadian/US wire gauge sizes, are		—
	- rated 125 per cent of the equipment rating, and		—
	- are specially marked when specified (1.7.7).		—
3.3.5	Revise first column of Table 3E to "Smaller of the RATED CURRENT of the equipment or the PROTECTIVE CURRENT RATING of the circuit under consideration."		—
3.4.2	Motor control devices are provided for cord-connected equipment with a motor if the equipment is rated more than 12 A,	No motor.	N/A
	- or if the motor has a nominal voltage rating greater than 120 V		N/A
	- or is rated more than 1/3 hp (locked rotor current over 43 A)		N/A
3.4.8	Vertically-mounted disconnect switches and circuit breakers have the "on" position indicated by the handle in the up position.	No such device.	N/A
3.4.11	For computer room applications, equipment with battery systems capable of supplying 750 VA for five minutes have a battery disconnect means that may be connected to the computer room remote power-off circuit.	No battery in the equipment.	N/A
4.3.12	The maximum quantity of flammable liquid stored in equipment complies with NFPA 30.	No liquids within the equipment.	N/A

IEC60950-1C ATTACHMENT			
Clause	Requirement + Test	Result - Remark	Verdict
4.3.13.5	Equipment with lasers meet the Canadian Radiation Emitting Devices Act, REDR C1370 and/or Code of Federal Regulations 21 CFR 1040, as applicable.	No lasers.	N/A
4.7	For computer room applications, automated information storage systems with combustible media greater than 0.76 m ³ (27 cu ft) have a provision for connection of either automatic sprinklers or a gaseous agent extinguishing system with an extended discharge.	The equipment has no combustible area greater than 0.76 m ³ .	N/A
4.7.3.1	For computer room applications, enclosures with combustible material measuring greater than 0.9 m ² (10 sq ft) or a single dimension greater than 1.8 m (6 ft) have a flame spread rating of 50 or less.		N/A
	For other applications, enclosures with the same dimensions require a flame spread rating of 200 or less.		N/A
Annex H	Equipment that produces ionizing radiation complies with U.S. Code of Federal Regulations, 21 CFR 1020 (and the Canadian Radiation Emitting Devices Act, REDR C1370).	The equipment is not produces ionizing radiation.	N/A
Other National Differences			
1.5.1	Some components and materials associated with the risk of fire, electric shock, or personal injury have component or material ratings in accordance with the applicable national (Canadian and/or U.S.) component or material standard requirements.	All critical components are IEC or UL certified. See component list 1.5.1.	P
1.6.1.2	A circuit for connection to the DC Mains Supply is classified as either a SELV Circuit, TNV-2 Circuit or Hazardous Voltage Circuit depending on the maximum operating voltage of the supply.	No connection to DC mains.	N/A
	This maximum operating voltage includes consideration of the battery charging "float voltage" associated with the intended supply system, regardless of the marked power rating of the equipment.		N/A
2.3.1	For TNV-2 and TNV-3 circuits with other than ringing signals and with voltages exceeding 42.4 V _{peak} or 60 V _{d.c.} , the maximum acceptable current through a 2000 ohm resistor (or greater) connected across the voltage source with other loads disconnected is 7.1 mA peak or 30 mA d.c. under normal operating conditions.	No TNV circuitry.	N/A
2.3.2.1	In the event of a single fault between TNV and SELV circuits, the limits of 2.2.3 apply to SELV Circuits and accessible conductive parts.		N/A

IEC60950-1C ATTACHMENT			
Clause	Requirement + Test	Result - Remark	Verdict
2.6.3.4	Protective bonding conductors of non-standard protective bonding constructions (e.g., printed circuit traces) may be subjected to the additional limited short circuit test conditions specified.	No such construction.	N/A
4.2.8.1	Enclosures around CRTs with a face diameter of 160 mm or more reduce the risk of injury due to the implosion of the CRT.	No CRT.	N/A
4.3.2	Equipment with handles complies with special loading tests.	No handle.	N/A
5.1.8.3	Equipment intended to receive telecommunication ringing signals comply with a special touch current measurement tests.	No TNV circuitry.	N/A
5.3.7	Internal (e.g., card cage) SELV circuit connectors and printed wiring board connectors that are accessible to the operator and that deliver power are overloaded.	No such connectors.	N/A
	During abnormal operating testing, if a circuit is interrupted by the opening of a component, the test shall be repeated twice (three tests total) using new components as necessary		N/A
6.4	Equipment intended for connection to telecommunication network outside plant cable is protected against overvoltage from power line crosses in accordance with 6.4 and Annex NAC.	No TNV circuitry.	N/A
Annex EE	Articulated accessibility probe (Fig EE.3) is used for assessing accessibility to document/media shredders instead of the Figure 2A test finger.	This equipment is not document shredding machines.	N/A
Annex M.2	Continuous ringing signals up to 16 mA only are permitted if the equipment is subjected to special installation and performance restrictions.	No TNV circuitry	N/A
Annex NAD	Equipment connected to a telecommunication and cable distribution networks and supplied with an earphone intended to be held against, or in the ear comply with special acoustic pressure requirements.	No TNV circuitry	N/A



Report No. 232812-1

TEST REPORT

Applicant	GlobTek, Inc.
Address	186 Veterans Dr. Northvale, NJ 07647 USA
Product	ITE power adaptor
Model No.	GT-93020-0324
Electrical Rating	Input:16-24Vac,50-60Hz,2.0A
Manufacturer Name:	GlobTek, Inc.
Address:	186 Veterans Dr. Northvale, NJ 07647 USA
Factory Name:	1. GlobTek, Inc. 2. GlobTek (Suzhou) Co., Ltd
Address	1. 186 Veterans Dr. Northvale, NJ 07647 USA 2. Building 4, No. 76, Jinling East Road, Suzhou Industrial Park, Suzhou, Jiangsu 215021, China
Testing Laboratory	Nemko Shanghai Ltd.
Address	7th Floor, Building 1, No. 2007 Hongmei Road, Xuhui District, Shanghai, China
Number of Samples received	1 (Sample No. 2013030101-5)
Test Model:	
Date of samples reception	2013-03-01
Date (s) of performance of tests	2013-03-28
Date of issue	2013-03-28
Test Requested	IP21 according to the applicant's requirements
Relating to Test Report	N/A
Test Method (standards)	The sample(s) tested consider to IEC 60529: 2001 clause 13 , 14
Test result	Pass
CONCLUSION	The submitted samples comply with applicant's requirements. This report applies only to the particular sample unit test and to the specific tests carried out as detailed in this report. The results contained in this report only relate to the adaptor body and except the input connector and output connector.

Prepared and checked by:

Sura Jiang

Reviewed by:

Lance Lei

This report details the results of the testing carried out on one sample. The results contained in this test report do not relate to other samples of the same product.

This report may only be reproduced and distributed in full. If the product in this report is used in any configuration other than that detailed in the report, the manufacturer must ensure the new system complies with all relevant standards.



Report No. 232812-1

TEST RESULTS**Standards used** IEC 60529: 2001 clause 13 , 14

Clause	Requirement + Test	Result – Remark	Verdict
13.2	IP2X	Tested on sample No. 2013030101-5. The object probe, a rigid sphere without handle or guard 12.5mm diameter, is pushed against any opening of the enclosure with 30N. The probe can not entered, and no access to inward of conductive parts.	Pass
14.2.1	IP X1	Tested on sample No. 2013030101-5. The water entered the enclosure but did not access to inward of live parts.	Pass

TEST PREPARATION:

1. The test samples for each test are in a clean and new condition.

TEST CONDITION:

Test A

The protection is satisfactory if the full diameter of the probe specified in table 7 of IEC 60529 does not pass through any opening.

1: Chamber: Rigid sphere without handle or guard 12.5 mm diameter

2: Application force: 30 N

Test B

1. An apparatus which produces a uniform flow of water drops over the whole area of the enclosure.

2. Duration of test:10 mins

3. Water flow rate: 1 l/min

OBSERVATIONS:

Refer to above table.

ELECTRIC STRENGTH MEASUREMENTS:

test voltage applied between:	test voltage (V)	breakdown
Between live parts of different polarity	N/A	N/A
Between live parts and the mounting surface	N/A	N/A
Between live parts and metal parts of the luminare	N/A	N/A

This report details the results of the testing carried out on one sample. The results contained in this test report do not relate to other samples of the same product.

This report may only be reproduced and distributed in full. If the product in this report is used in any configuration other than that detailed in the report, the manufacturer must ensure the new system complies with all relevant standards.

Attachment 1: Pictures



Sample before test, Model 4 GT-93020-0324, Sample No. 2013030101-5

This report details the results of the testing carried out on one sample. The results contained in this test report do not relate to other samples of the same product.

This report may only be reproduced and distributed in full. If the product in this report is used in any configuration other than that detailed in the report, the manufacturer must ensure the new system complies with all relevant standards.



Sample after IPX1 test, Model 4 GT-93020-0324, Sample No. 2013030101-5

The water entered the enclosure but did not access to inward of live parts (marked with red arrow).

This report details the results of the testing carried out on one sample. The results contained in this test report do not relate to other samples of the same product.

This report may only be reproduced and distributed in full. If the product in this report is used in any configuration other than that detailed in the report, the manufacturer must ensure the new system complies with all relevant standards.

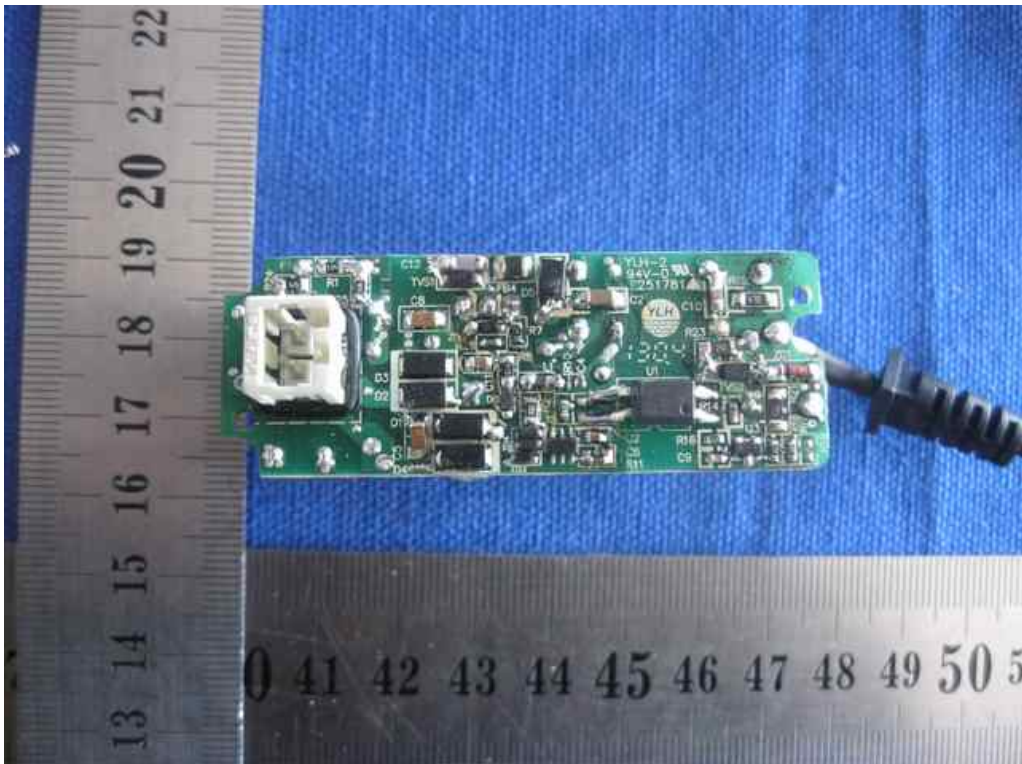

Sample after IPX1 test, Model 4 GT-93020-0324, Sample No. 2013030101-5
The water did not entered the inside enclosure.

*****End of Report *****

This report details the results of the testing carried out on one sample. The results contained in this test report do not relate to other samples of the same product.

This report may only be reproduced and distributed in full. If the product in this report is used in any configuration other than that detailed in the report, the manufacturer must ensure the new system complies with all relevant standards.