



TEST REPORT

Reference No..... : WTX22X07139237E

Applicant : GlobTek, Inc.

Address : 186 Veterans Dr. Northvale, NJ 07647 USA

Manufacturer : 1: GlobTek, Inc.
2: GlobTek (Suzhou) Co., Ltd
1: 186 Veterans Dr. Northvale, NJ 07647 USA

Address : 2: Building 4, No. 76, Jin Ling East Rd., Suzhou Industrial Park,
Suzhou,JiangSu 215021, China

Product Name : ITE Power Supply

Model No..... : GT*46401-**** (Replaceable plug); GT*46401-***-W2Z* (Fixed plug)

Standards : EN 55032:2015+A11:2020
EN 55035:2017+A11:2020
EN IEC 61000-3-2:2019
EN 61000-3-3:2013+A1:2019

Date of Receipt sample : 2022-07-08

Date of Test..... : 2022-07-08 to 2022-07-21

Date of Issue : 2022-07-21

Test Report Form No. : WTX_EN 55032_2015_B

Test Result..... : Pass

Remarks:

The results shown in this test report refer only to the sample(s) tested, this test report cannot be reproduced, except in full, without prior written permission of the company. The report would be invalid without specific stamp of test institute and the signatures of approver.

Prepared By:

Waltek Testing Group (Shenzhen) Co., Ltd.

Address: 1/F., Room 101, Building 1, Hongwei Industrial Park, Liuxian 2nd Road,
Block 70 Bao'an District, Shenzhen, Guangdong, China

Tel.: +86-755-33663308 Fax.: +86-755-33663309 Email: sem@waltek.com.cn

Tested by:

Taylor Wu

Taylor Wu

Approved by:

Silin Chen

Silin Chen



TABLE OF CONTENTS

1. GENERAL INFORMATION.....4

1.1 PRODUCT DESCRIPTION FOR EQUIPMENT UNDER TEST (EUT).....4

1.2 TEST STANDARDS.....5

1.3 TEST METHODOLOGY.....5

1.4 EUT SETUP AND OPERATION MODE6

1.5 PERFORMANCE CRITERIA FOR EMS6

1.6 TEST EQUIPMENT LIST AND DETAILS7

2. SUMMARY OF TEST RESULTS9

3. CONDUCTED EMISSION.....10

3.1 MEASUREMENT UNCERTAINTY10

3.2 BASIC TEST SETUP BLOCK DIAGRAM.....10

3.3 ENVIRONMENTAL CONDITIONS11

3.4 SUMMARY OF TEST RESULTS11

4. RADIATED EMISSION16

4.1 MEASUREMENT UNCERTAINTY16

4.2 BASIC TEST SETUP BLOCK DIAGRAM.....16

4.3 CORRECTED AMPLITUDE & MARGIN CALCULATION.....17

4.4 ENVIRONMENTAL CONDITIONS17

4.5 SUMMARY OF TEST RESULTS17

5. HARMONIC CURRENT EMISSIONS22

5.1 TEST PROCEDURE.....22

5.2 TEST STANDARDS22

5.3 ENVIRONMENTAL CONDITIONS.....22

5.4 BASIC TEST SETUP BLOCK DIAGRAM.....22

5.5 HARMONIC CURRENT EMISSIONS TEST DATA.....22

6. VOLTAGE FLUCTUATION FLICKER.....33

6.1 TEST PROCEDURE.....33

6.2 TEST STANDARDS33

6.3 ENVIRONMENTAL CONDITIONS.....33

6.4 BASIC TEST SETUP BLOCK DIAGRAM.....33

6.5 VOLTAGE FLUCTUATION AND FLICKER TEST DATA.....33

7. ELECTROSTATIC DISCHARGES (ESD)36

7.1 TEST PROCEDURE.....36

7.2 TEST PERFORMANCE36

7.3 ENVIRONMENTAL CONDITIONS.....36

7.4 BASIC TEST SETUP BLOCK DIAGRAM.....36

7.5 ELECTROSTATIC DISCHARGE IMMUNITY TEST DATA37

8. CONTINUOUS RF ELECTROMAGNETIC FIELD DISTURBANCES (RS)38

8.1 TEST PROCEDURE.....38

8.2 TEST PERFORMANCE38

8.3 ENVIRONMENTAL CONDITIONS38

8.4 BASIC TEST SETUP BLOCK DIAGRAM.....38

8.5 CONTINUOUS RADIATED DISTURBANCES TEST DATA39

9. ELECTRICAL FAST TRANSIENTS (EFT).....40

9.1 TEST PROCEDURE.....40

9.2 TEST PERFORMANCE40

9.3 ENVIRONMENTAL CONDITIONS40

9.4 BASIC TEST SETUP BLOCK DIAGRAM.....40

9.5 ELECTRICAL FAST TRANSIENTS TEST DATA.....41

10. SURGES42

10.1 TEST PROCEDURE.....42



Reference No.: WTX22X07139237E

10.2 TEST PERFORMANCE	42
10.3 ENVIRONMENTAL CONDITIONS	42
10.4 BASIC TEST SETUP BLOCK DIAGRAM	42
10.5 SURGE TEST DATA	43
11. CONTINUOUS INDUCED RF DISTURBANCES (C/S)	44
11.1 TEST PROCEDURE	44
11.2 TEST PERFORMANCE	44
11.3 ENVIRONMENTAL CONDITIONS	44
11.4 BASIC TEST SETUP BLOCK DIAGRAM	44
11.5 CONTINUOUS CONDUCTED DISTURBANCES TEST DATA	45
12. POWER-FREQUENCY MAGNETIC FIELDS (PFMF)	46
12.1 TEST PROCEDURE	46
12.2 TEST PERFORMANCE	46
12.3 ENVIRONMENTAL CONDITIONS	46
12.4 BASIC TEST SETUP BLOCK DIAGRAM	46
12.5 POWER-FREQUENCY MAGNETIC FIELD TEST DATA	47
13. VOLTAGE DIPS AND INTERRUPTIONS.....	48
13.1 TEST PROCEDURE	48
13.2 TEST PERFORMANCE	48
13.3 ENVIRONMENTAL CONDITIONS	48
13.4 BASIC TEST SETUP BLOCK DIAGRAM	48
13.5 VOLTAGE DIPS AND INTERRUPTIONS TEST DATA	49
EXHIBIT 1 - PRODUCT LABELING	50
PROPOSED CE LABEL FORMAT	50
PROPOSED LABEL LOCATION ON EUT	50
EXHIBIT 2 - EUT PHOTOGRAPHS.....	51
EXHIBIT 3 - TEST SETUP PHOTOGRAPHS.....	59





1. GENERAL INFORMATION

1.1 Product Description for Equipment Under Test (EUT)

General Description of EUT	
Product Name:	ITE Power Supply
Trade Name:	
Model No.:	GT*46401-**** (Replaceable plug); GT*46401-***-W2Z* (Fixed plug)
Adding Model(s):	/
<p><i>Note: The test data is gathered from a production sample, provided by the manufacturer. The appearance of others models listed in the report is different from main-test model GT*46401-**** (Replaceable plug); GT*46401-***-W2Z* (Fixed plug), but the circuit and the electronic construction do not change, declared by the manufacturer.</i></p> <p><i>GT*46401-**** (Replaceable plug); GT*46401-***-W2Z* (Fixed plug)</i> <i>(The 1st "*" part can be 'M' or '-' or 'H' for market identification and not related to safety.)</i> <i>(The 2rd "*" denotes the rated output wattage designation, with a maximum value of "40".)</i> <i>(The 3th "*" denotes the standard rated output voltage designation, which can be "12", "15", "19", "24", "48".)</i> <i>(The 4th "*" is optional deviation, subtracted from standard output voltage, which can be "-0.1" to "-23.9" with interval of 0.1, or blank to indicate no voltage different.)</i> <i>(Z designates type of plug and can be E for European plug, U for British plug, blank for North American / Japan plug/Taiwan plug, C for Chinese plug, I for India plug, A for Australia plug, K for Korea plug, AR for Argentina plug, BR for Brazilian plug, SA or AF for South African plug.)</i> <i>(-W2Z can be optional, when it is blank, denote to be with replaceable plug)</i> <i>(The last "*" denote any six character means "0-9", "A-Z", "()", "[]", "-" or blank for marketing purposes.)</i></p>	

Technical Characteristics of EUT	
Rated Voltage:	AC 100-240V~50-60Hz
Rated Current:	/
Rated Power:	/
Power Adaptor Model:	/
Highest Internal Frequency:	Below 108MHz
Classification of Equipment:	Class B



1.2 Test Standards

The tests were performed according to following standards:

EN 55032:2015+A11:2020: Electromagnetic compatibility of multimedia equipment - Emission requirements.

EN 55035:2017+A11:2020: Electromagnetic compatibility of multimedia equipment - Immunity requirements.

EN IEC 61000-3-2:2019: Electromagnetic compatibility (EMC) -- Part 3-2: Limits - Limits for harmonic current emissions (equipment input current up to and including 16 A per phase).

EN 61000-3-3:2013+A1:2019: Electromagnetic compatibility (EMC) -- Part 3-3: Limits - Limitation of voltage changes, voltage fluctuations and flicker in public low-voltage supply systems, for equipment with rated current ≤ 16 A per phase and not subject to conditional connection.

Maintenance of compliance is the responsibility of the manufacturer. Any modification of the product maybe which result in lowering the emission/immunity should be checked to ensure compliance has been maintained.

1.3 Test Methodology

All measurements contained in this report were conducted with the standards EN 55032, EN IEC 61000-3-2, EN 61000-3-3 and EN 55035 for electromagnetic compatibility of multimedia equipment, and all related testing and measurement techniques intentional standards.



1.4 EUT Setup and Operation Mode

The equipment under test (EUT) was configured to measure its highest possible emission/immunity level. The test modes were adapted according to the operation manual for use, more detailed description as follows:

Test Mode List			
Test Mode	Description	Remark	Power Supply Mode
TM1	Working:48V0.83A (GT-46401-4048)	output port is connected to the Cement load(58R)	AC230V/50Hz
TM2	Working:12V3A (GT-46401-3612)	output port is connected to the Cement load(4R)	AC230V/50Hz

Note: The product was measured at two nominal voltages of 230V and 110V, using a frequency of 50Hz or 60Hz. This report shows the worst case with 230V/50Hz data.

EUT Cable List and Details				
Cable Description	Length (m)	Shielded/Unshielded	With / Without Ferrite	With / Without Chip
output cable(TM1)	1.78	Unshielded	With	Without
output cable(TM2)	1.2	Unshielded	With	Without

Special Cable List and Details				
Cable Description	Length (m)	Shielded/Unshielded	With / Without Ferrite	With / Without Chip
/	/	/	/	/

Auxiliary Equipment List and Details				
Description	Manufacturer	Model	Serial Number	
/	/	/	/	

1.5 Performance Criteria for EMS

All the test data has been collected, reduced, and analyzed within this report in accordance with Immunity requires the following as specific performance criteria:

- A. The apparatus shall continue to operate as intended during and after the test. The manufacturer specifies some minimum performance level. The performance level may be specified by the manufacturer as a permissible loss of performance.
- B. The apparatus shall continue to operate as intended after the test. This indicates that the EUT does not need to function at normal performance levels during the test, but must recover. Again some minimal performance is defined by the manufacturer. No change in operating state or loss of data is permitted.
- C. Temporary loss of function is allowed. Operation of the EUT may stop as long as it is either automatically reset or can be manually restored by operation of the controls.



1.6 Test Equipment List and Details

Description	Manufacturer	Model	Serial No.	Cal. Date	Due. Date
<input type="checkbox"/> Chamber A: Below 1GHz					
Spectrum Analyzer	Rohde & Schwarz	FSP30	836079/035	2022-03-22	2023-03-21
EMI Test Receiver	Rohde & Schwarz	ESVB	825471/005	2022-03-22	2023-03-21
Trilog Broadband Antenna	Schwarz beck	VULB9163	9163-333	2021-03-20	2023-03-19
Loop Antenna	Schwarz beck	FMZB 1516	9773	2021-03-20	2023-03-19
Amplifier	HP	8447F	2805A03475	2022-01-07	2023-01-06
<input type="checkbox"/> Chamber A: Above 1GHz					
Amplifier	C&D	PAP-1G18	2002	2022-03-22	2023-03-21
Horn Antenna	ETS	3117	00086197	2021-03-19	2023-03-18
<input checked="" type="checkbox"/> Chamber B: Below 1GHz					
Trilog Broadband Antenna	Schwarz beck	VULB9163(B)	9163-635	2021-04-09	2023-04-08
Amplifier	Agilent	8447D	2944A10179	2022-03-22	2023-03-21
EMI Test Receiver	Rohde & Schwarz	ESPI	101391	2022-03-25	2023-03-24
<input type="checkbox"/> Chamber C: Below 1GHz					
EMI Test Receiver	Rohde & Schwarz	ESIB 26	100401	2022-01-07	2023-01-06
Trilog Broadband Antenna	Schwarz beck	VULB 9168	1194	2021-05-28	2023-05-27
Amplifier	HP	8447F	2944A03869	2022-03-22	2023-03-21
<input checked="" type="checkbox"/> Conducted Room 1#					
EMI Test Receiver	Rohde & Schwarz	ESPI	101611	2022-03-22	2023-03-21
Pulse Limiter	Rohde & Schwarz	ESH3-Z2	100911	2022-03-25	2023-03-24
AC LISN	Schwarz beck	NSLK8126	8126-224	2022-03-22	2023-03-21
8-WIRE LISN	Schwarz beck	8158	CAT3-8158-0059	2022-03-22	2023-03-21
8-WIRE LISN	Schwarz beck	8158	CAT5-8158-0117	2022-03-22	2023-03-21
<input type="checkbox"/> Conducted Room 2#					
EMI Test Receiver	Rohde & Schwarz	ESPI	10129	2022-03-22	2023-03-21
LISN	Rohde & Schwarz	ENV 216	100097	2022-03-22	2023-03-21
<input checked="" type="checkbox"/> Harmonics & Flicker					
Digital Power Analyzer	California Instrument	CTS	72831	2022-03-22	2023-03-21
Power Source	California Instrument	5001IX-CTS-400	25965	2022-03-22	2023-03-21
<input checked="" type="checkbox"/> Electrostatic discharges					
ESD Generator	LIONCEL	ESD-203B	0170901	2022-03-28	2023-03-27
<input checked="" type="checkbox"/> Power-frequency magnetic field (PFMF)					
PMF Generator	LIONCEL	PMF-801C-C	0171101	2022-03-22	2023-03-21
PMF Antenna	LIONCEL	PMF-801C-A	0180302	2022-03-22	2023-03-21



Instantaneous PMF Generator Module	LIONCEL	PMF-801C-T	0171001	2022-03-22	2023-03-21
<input checked="" type="checkbox"/> Electronic fast transient(EFT)/Surges/Dips					
Transient 2000	EMC PARTNER	TRA2000	863	2022-03-22	2023-03-21
Couple Clamp	EMC PARTNER	CN-EFT1000	513	2022-03-22	2023-03-21
<input checked="" type="checkbox"/> Radio frequency, continuous conducted (C/S)					
CONDUCTED IMMUNITY TEST SYSTEM	FRANKONIA	CIT-10/75	126B1247/2013	2022-01-07	2023-01-06
Attenuator	EMTEST	MA-5100/6BF2	1009	2022-03-22	2023-03-21
CDN	Luthi	L-801M2/M3	2665	2022-03-22	2023-03-21
CDN	LIONCEL	CDN-T8	0210401	2022-03-25	2023-03-24
EM Clamp	TESEQ	KEMZ801A	45028	2022-03-25	2023-03-24
<input checked="" type="checkbox"/> Radio frequency electromagnetic Field (R/S)					
Signal Generator	HP	8688B	3438A00604	2022-03-22	2023-03-21
Power Sensor	Agilent	E9301A	MY52450001	2022-03-25	2023-03-24
Power Sensor	Agilent	E9304A	MY55081055	2022-03-25	2023-03-24
RF Power Amplifier	MicoTop	MPA-80-1000-250	MPA1906239	2022-03-22	2023-03-21
RF Power Amplifier	MicoTop	MPA-1000-6000-100	MPA1906238	2022-03-22	2023-03-21
Antenna	SCHWARZBECK	STLP 9129	9129 114	N/A	N/A
Power Meter	Agilent	E4419B	GB42420578	2022-03-22	2023-03-21



2. SUMMARY OF TEST RESULTS

Standards	Description of Test Item	Result
EN 55032	Conducted Emission	Compliant
	Radiated Emission	Compliant
EN IEC 61000-3-2	Harmonic Current Emission	Compliant
EN 61000-3-3	Voltage Fluctuation and Flicker	Compliant
EN 55035	Electrostatic Discharge Immunity in accordance with EN 61000-4-2	Compliant
	Continuous RF electromagnetic field Disturbances Immunity in accordance with EN 61000-4-3	Compliant
	Electrical Fast Transient/Burst Immunity in accordance with EN 61000-4-4	Compliant
	Surges Immunity in accordance with EN 61000-4-5	Compliant
	Continuous induced RF disturbances Immunity in accordance with EN 61000-4-6	Compliant
	Power-frequency Magnetic Fields Immunity in accordance With EN 61000-4-8	Compliant
	Voltage Dips/Interruptions Immunity in accordance with EN 61000-4-11	Compliant
	Broadband impulse noise disturbances, repetitive	N/A
Broadband impulse noise disturbances, isolated	N/A	

N/A: not applicable



3. Conducted Emission

3.1 Measurement Uncertainty

Base on NIS 81, The Treatment of Uncertainty in EMC Measurements, the best estimate of the uncertainty of any conducted emissions measurement:

Measurement uncertainty		
Parameter	Conditions	Uncertainty
Conducted Emissions	Conducted	9-150kHz $\pm 3.74\text{dB}$
		0.15-30MHz $\pm 3.34\text{dB}$

3.2 Basic Test Setup Block Diagram

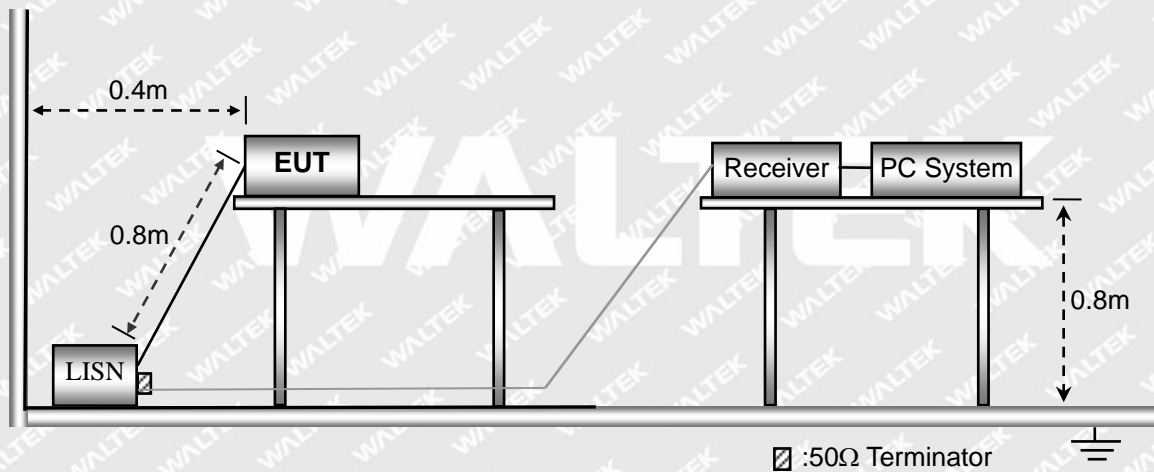



3.3 Environmental Conditions

Temperature:	21.5 °C
Relative Humidity:	48 %
ATM Pressure:	1012 mbar

3.4 Summary of Test Results

Please find the results below:

WALTEK



GT-46401-4048

Test mode:	TM1	Polarity:	Line
------------	-----	-----------	------

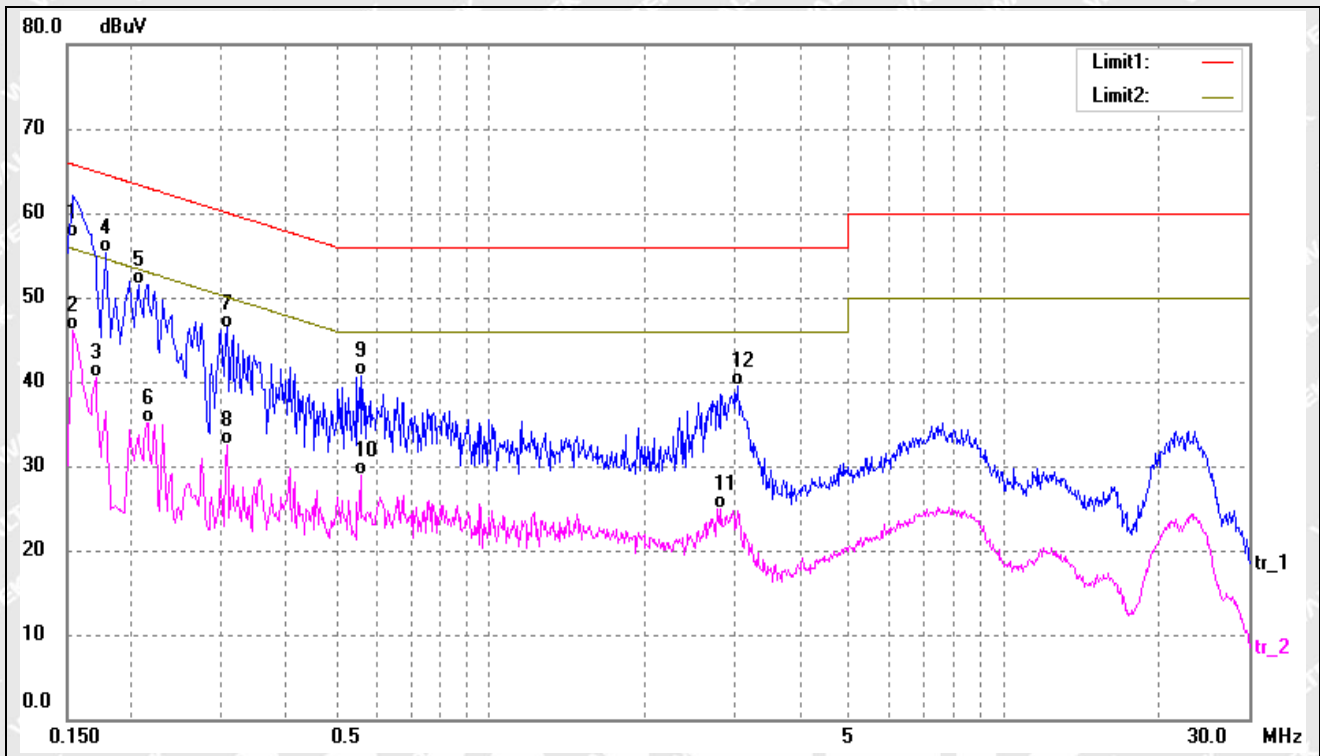

No.	Frequency (MHz)	Reading (dBuV)	Correct (dB)	Result (dBuV)	Limit (dBuV)	Margin (dB)	Detector
1*	0.1540	46.76	10.32	57.08	65.78	-8.70	QP
2	0.1540	35.78	10.32	46.10	55.78	-9.68	AVG
3	0.1700	30.22	10.31	40.53	54.96	-14.43	AVG
4	0.1780	44.93	10.31	55.24	64.58	-9.34	QP
5	0.2060	41.28	10.29	51.57	63.37	-11.80	QP
6	0.2140	24.89	10.29	35.18	53.05	-17.87	AVG
7	0.3060	36.16	10.24	46.40	60.08	-13.68	QP
8	0.3060	22.21	10.24	32.45	50.08	-17.63	AVG
9	0.5580	30.55	10.21	40.76	56.00	-15.24	QP
10	0.5580	18.68	10.21	28.89	46.00	-17.11	AVG
11	2.8180	14.72	10.27	24.99	46.00	-21.01	AVG
12	3.0300	29.16	10.28	39.44	56.00	-16.56	QP



Test mode:	TM1	Polarity:	Neutral
------------	-----	-----------	---------

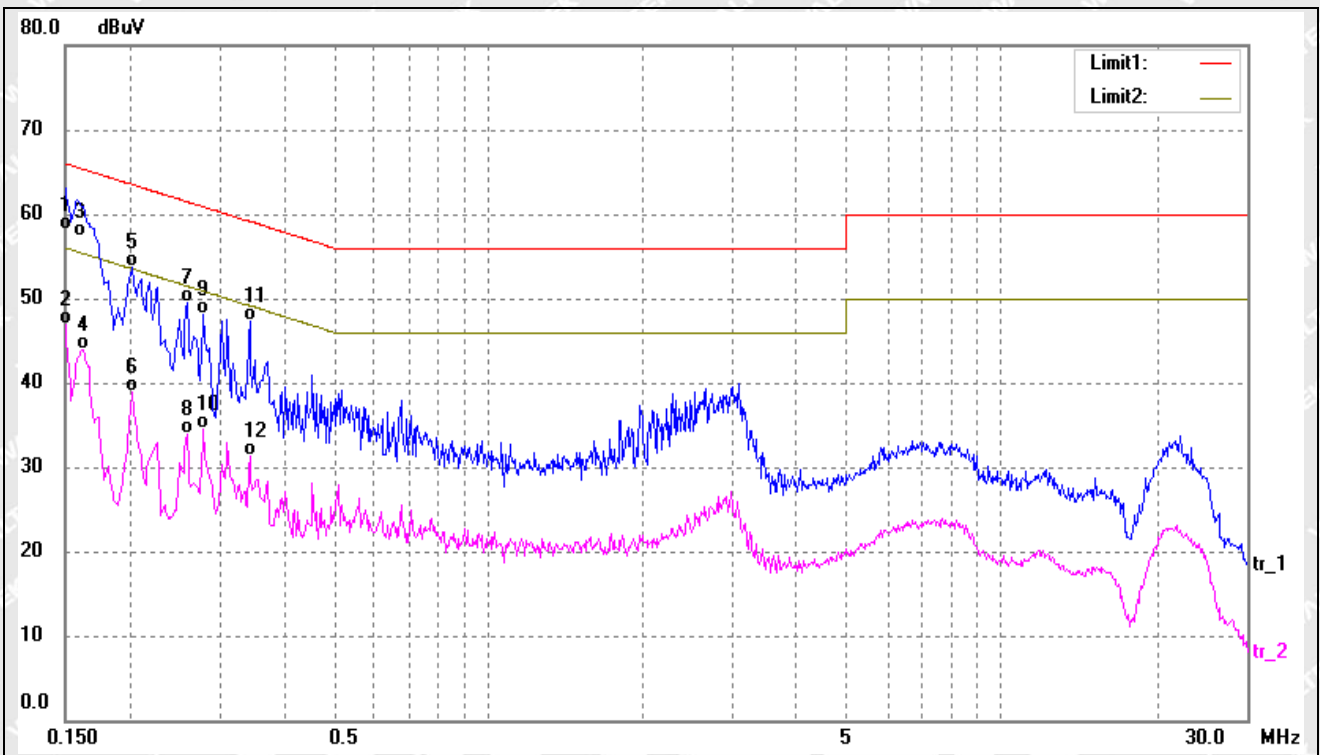

No.	Frequency (MHz)	Reading (dBuV)	Correct (dB)	Result (dBuV)	Limit (dBuV)	Margin (dB)	Detector
1*	0.1500	47.69	10.32	58.01	65.99	-7.98	QP
2	0.1500	36.65	10.32	46.97	55.99	-9.02	AVG
3	0.1580	46.93	10.31	57.24	65.56	-8.32	QP
4	0.1620	33.67	10.31	43.98	55.36	-11.38	AVG
5	0.2020	43.33	10.30	53.63	63.52	-9.89	QP
6	0.2020	28.58	10.30	38.88	53.52	-14.64	AVG
7	0.2580	39.18	10.26	49.44	61.49	-12.05	QP
8	0.2580	23.62	10.26	33.88	51.49	-17.61	AVG
9	0.2779	37.76	10.25	48.01	60.88	-12.87	QP
10	0.2779	24.17	10.25	34.42	50.88	-16.46	AVG
11	0.3420	37.11	10.23	47.34	59.15	-11.81	QP
12	0.3420	21.11	10.23	31.34	49.15	-17.81	AVG



GT-46401-3612

Test mode:	TM2	Polarity:	Line
------------	-----	-----------	------

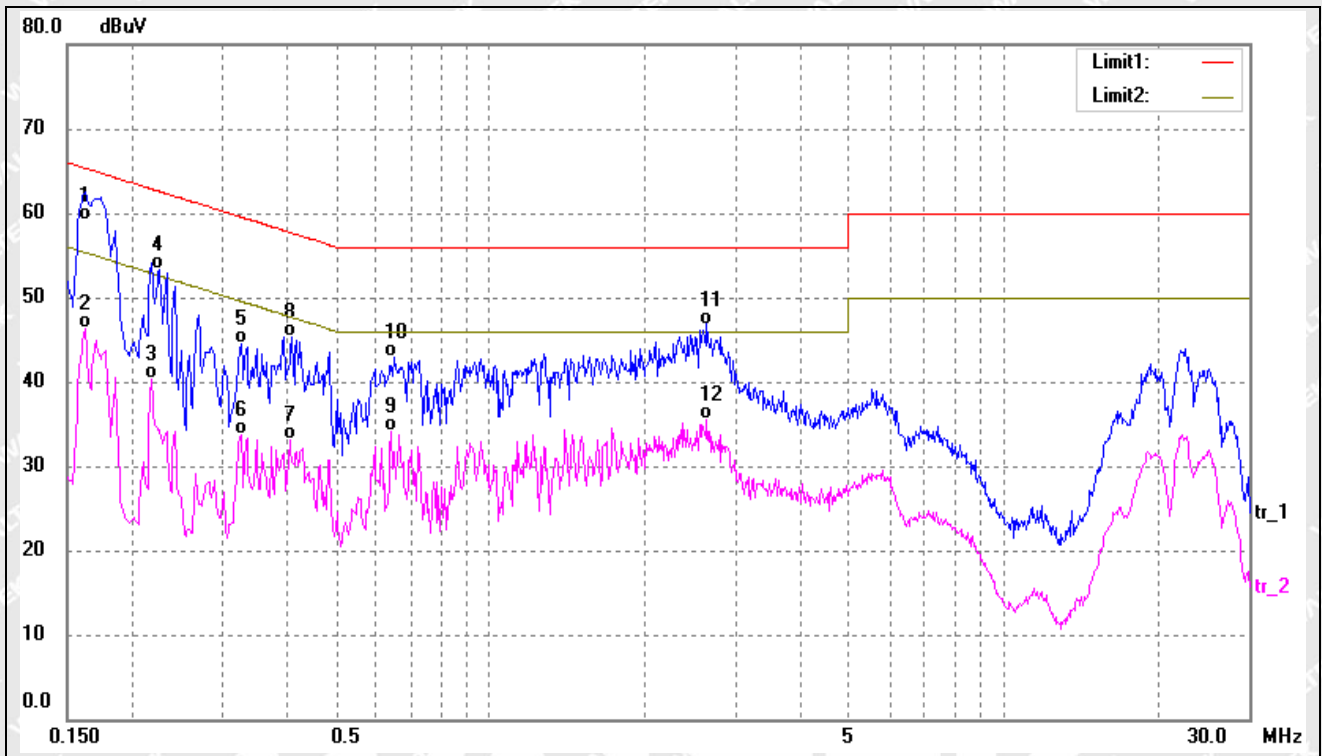

No.	Frequency (MHz)	Reading (dBuV)	Correct (dB)	Result (dBuV)	Limit (dBuV)	Margin (dB)	Detector
1*	0.1620	48.74	10.31	59.05	65.36	-6.31	QP
2	0.1620	36.00	10.31	46.31	55.36	-9.05	AVG
3	0.2180	30.03	10.28	40.31	52.89	-12.58	AVG
4	0.2260	42.95	10.28	53.23	62.59	-9.36	QP
5	0.3260	34.30	10.24	44.54	59.55	-15.01	QP
6	0.3260	23.50	10.24	33.74	49.55	-15.81	AVG
7	0.4060	22.92	10.22	33.14	47.73	-14.59	AVG
8	0.4100	35.01	10.22	45.23	57.65	-12.42	QP
9	0.6419	23.87	10.20	34.07	46.00	-11.93	AVG
10	0.6500	32.79	10.20	42.99	56.00	-13.01	QP
11	2.6380	36.53	10.27	46.80	56.00	-9.20	QP
12	2.6380	25.28	10.27	35.55	46.00	-10.45	AVG



Test mode:	TM2	Polarity:	Neutral
------------	-----	-----------	---------

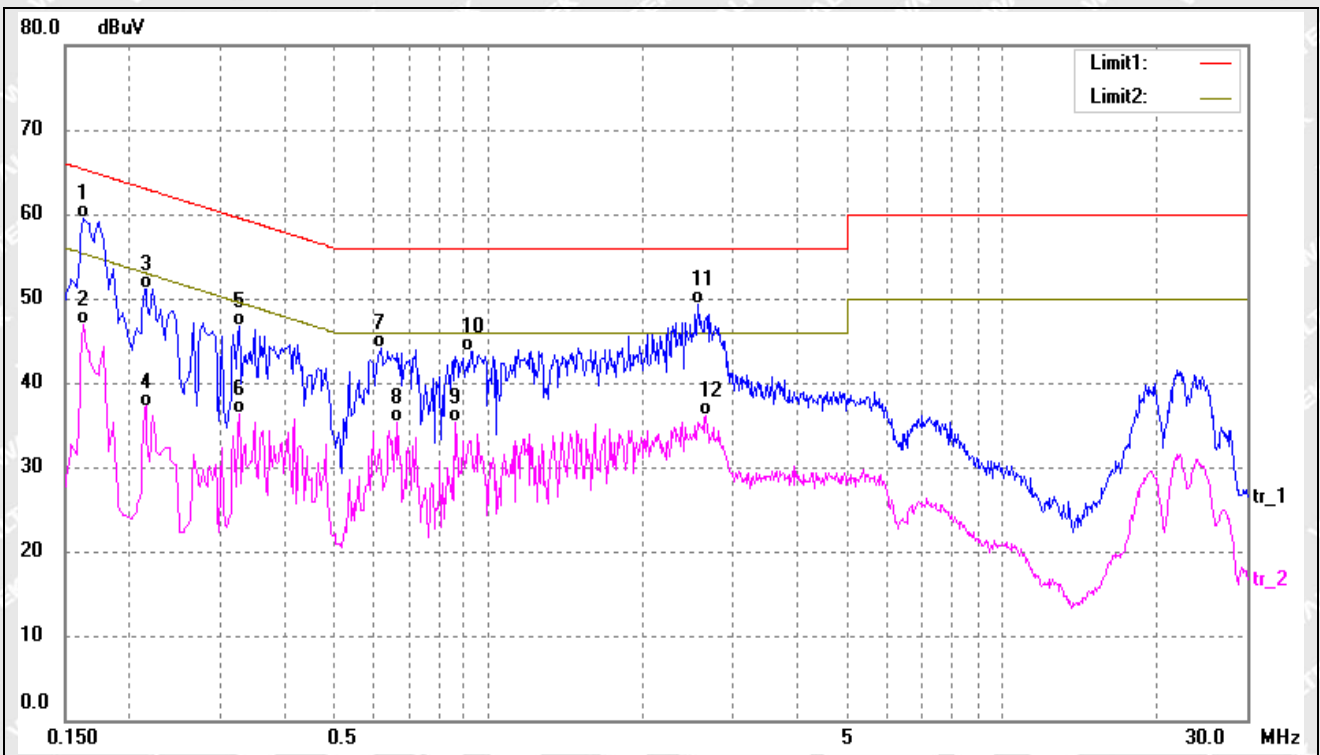

No.	Frequency (MHz)	Reading (dBuV)	Correct (dB)	Result (dBuV)	Limit (dBuV)	Margin (dB)	Detector
1*	0.1620	49.20	10.31	59.51	65.36	-5.85	QP
2	0.1620	36.69	10.31	47.00	55.36	-8.36	AVG
3	0.2140	40.89	10.29	51.18	63.05	-11.87	QP
4	0.2140	26.91	10.29	37.20	53.05	-15.85	AVG
5	0.3260	36.56	10.24	46.80	59.55	-12.75	QP
6	0.3260	26.09	10.24	36.33	49.55	-13.22	AVG
7	0.6180	33.91	10.20	44.11	56.00	-11.89	QP
8	0.6660	25.16	10.20	35.36	46.00	-10.64	AVG
9	0.8620	25.12	10.16	35.28	46.00	-10.72	AVG
10	0.9300	33.54	10.15	43.69	56.00	-12.31	QP
11	2.5620	38.98	10.26	49.24	56.00	-6.76	QP
12	2.6540	25.87	10.27	36.14	46.00	-9.86	AVG



4. Radiated Emission

4.1 Measurement Uncertainty

Base on NIS 81, The Treatment of Uncertainty in EMC Measurements, the best estimate of the uncertainty of any radiation emissions measurement:

Measurement uncertainty		
Parameter	Conditions	Uncertainty
Radiated Emissions	Radiated	30-200MHz $\pm 4.52\text{dB}$
		0.2-1GHz $\pm 5.56\text{dB}$
		1-6GHz $\pm 3.84\text{dB}$
		6-18GHz $\pm 3.92\text{dB}$

4.2 Basic Test Setup Block Diagram

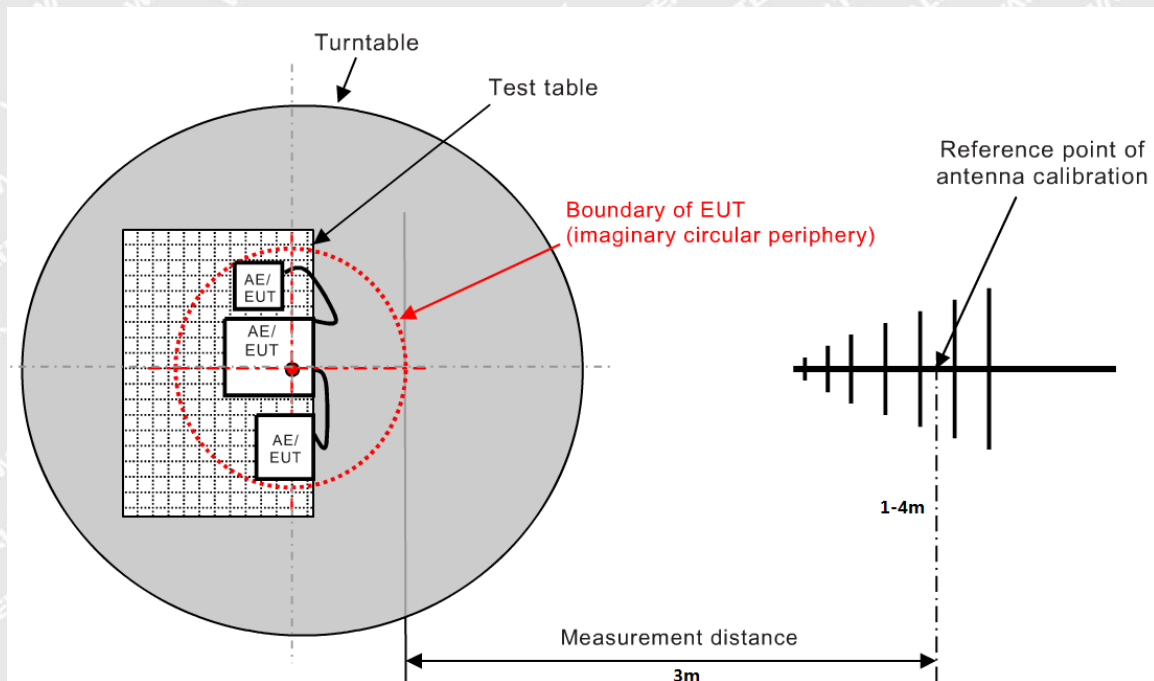



4.3 Corrected Amplitude & Margin Calculation

The Corrected Amplitude is calculated by adding the Antenna Factor and the Cable Factor, and subtracting the Amplifier Gain from the Amplitude reading. The basic equation is as follows:

$$\text{Corr. Ampl.} = \text{Indicated Reading} + \text{Correct Correct} = \text{Ant. Factor} + \text{Cable Loss} - \text{Ampl. Gain}$$

The “**Margin**” column of the following data tables indicates the degree of compliance with the applicable limit. For example, a margin of -6dB μ V means the emission is 6dB μ V below the maximum limit for Class B device. The equation for margin calculation is as follows:

$$\text{Margin} = \text{Corr. Ampl.} - \text{EN 55032 Class B Limit}$$

4.4 Environmental Conditions

Temperature:	22.5 °C
Relative Humidity:	51 %
ATM Pressure:	1010 mbar

4.5 Summary of Test Results

Please find the results below:



GT-46401-4048

Test mode:	TM1	Polarity:	Horizontal
------------	-----	-----------	------------

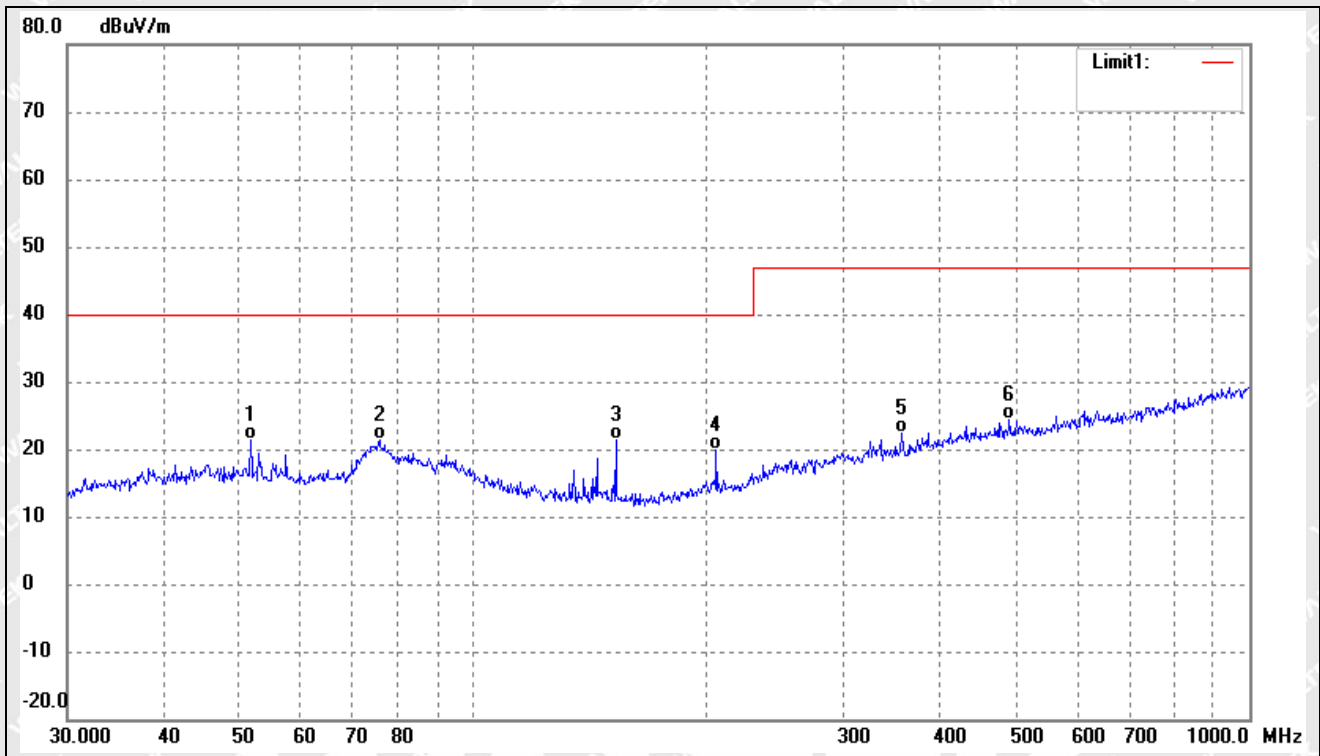

No.	Frequency (MHz)	Reading (dBuV/m)	Correct (dB/m)	Result (dBuV/m)	Limit (dBuV/m)	Margin (dB)	Degree ()	Height (cm)	Remark
1	51.6616	32.66	-11.21	21.45	40.00	-18.55	271	100	QP
2	75.7114	36.60	-15.14	21.46	40.00	-18.54	99	100	QP
3	152.6641	36.66	-15.16	21.50	40.00	-18.50	320	100	QP
4	205.6751	32.08	-12.23	19.85	40.00	-20.15	95	100	QP
5	356.6758	30.01	-7.63	22.38	47.00	-24.62	305	100	QP
6	490.7447	29.47	-5.19	24.28	47.00	-22.72	304	100	QP



Test mode:	TM1	Polarity:	Vertical
------------	-----	-----------	----------

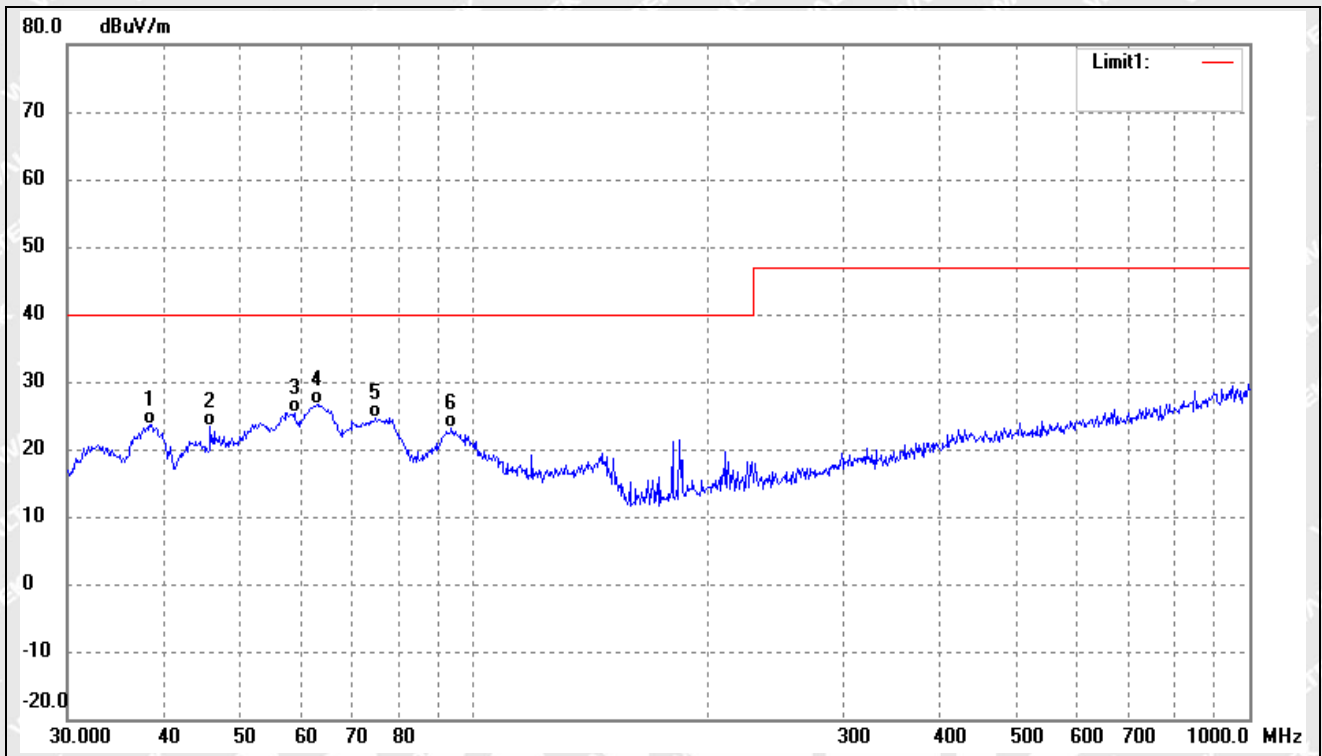

No.	Frequency (MHz)	Reading (dBuV/m)	Correct (dB/m)	Result (dBuV/m)	Limit (dBuV/m)	Margin (dB)	Degree ()	Height (cm)	Remark
1	38.3462	34.91	-11.20	23.71	40.00	-16.29	297	100	QP
2	45.8553	34.27	-10.89	23.38	40.00	-16.62	100	100	QP
3	58.8185	38.09	-12.60	25.49	40.00	-14.51	143	100	QP
4	62.8708	40.21	-13.49	26.72	40.00	-13.28	99	100	QP
5	74.9191	39.85	-15.14	24.71	40.00	-15.29	252	100	QP
6	93.7685	35.58	-12.50	23.08	40.00	-16.92	168	100	QP



GT-46401-3612

Test mode:	TM2	Polarity:	Horizontal
------------	-----	-----------	------------

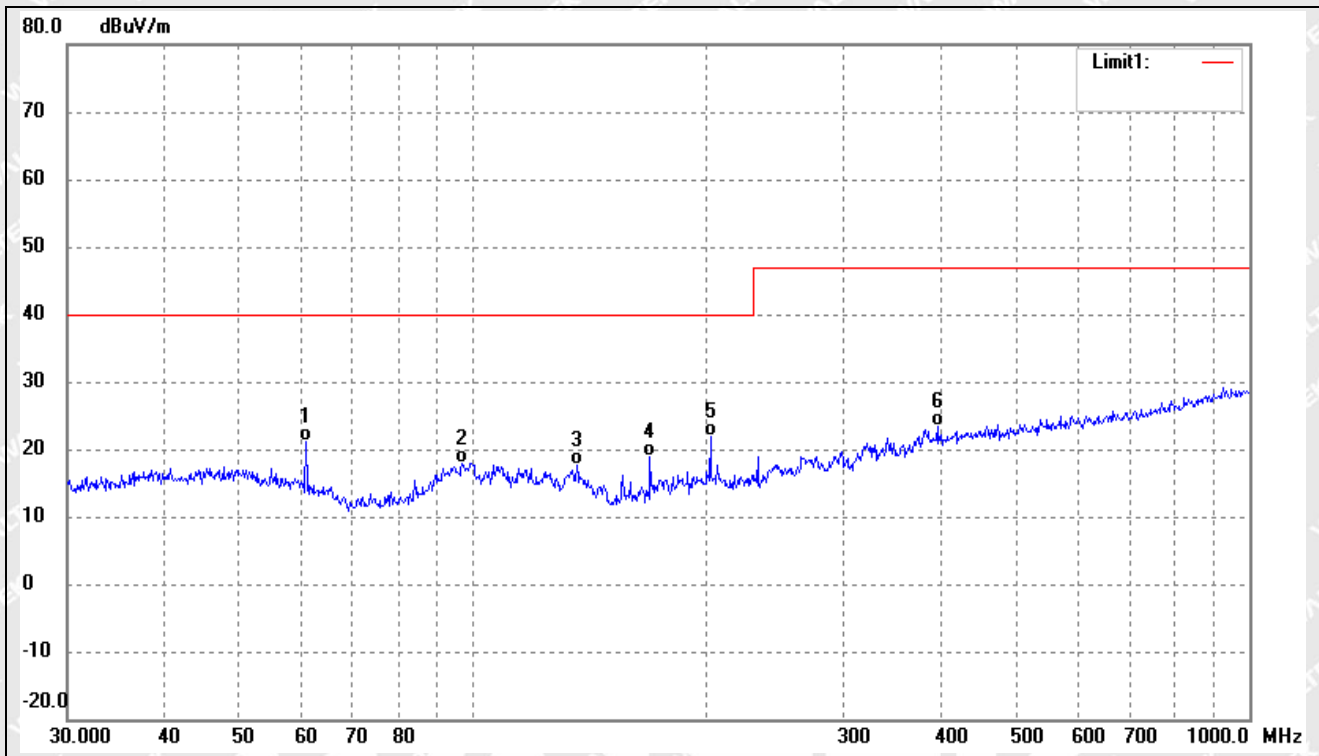

No.	Frequency (MHz)	Reading (dBuV/m)	Correct (dB/m)	Result (dBuV/m)	Limit (dBuV/m)	Margin (dB)	Degree ()	Height (cm)	Remark
1	60.9176	34.22	-13.04	21.18	40.00	-18.82	175	100	QP
2	96.7749	30.15	-12.27	17.88	40.00	-22.12	115	100	QP
3	135.9822	32.72	-15.03	17.69	40.00	-22.31	71	100	QP
4	169.0054	33.35	-14.45	18.90	40.00	-21.10	332	100	QP
5	202.1005	34.14	-12.33	21.81	40.00	-18.19	169	100	QP
6	396.2415	29.64	-6.36	23.28	47.00	-23.72	243	100	QP



Test mode:	TM2	Polarity:	Vertical
------------	-----	-----------	----------

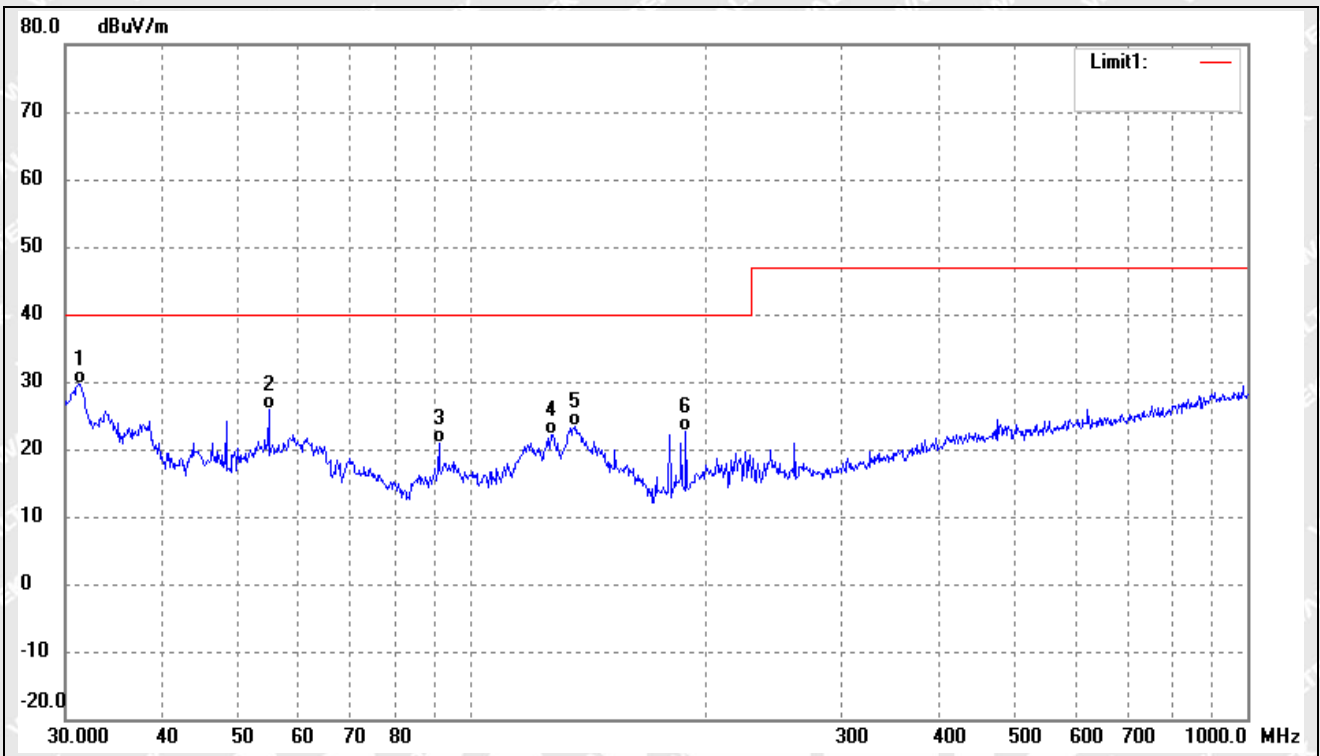

No.	Frequency (MHz)	Reading (dBuV/m)	Correct (dB/m)	Result (dBuV/m)	Limit (dBuV/m)	Margin (dB)	Degree ()	Height (cm)	Remark
1	31.2893	42.08	-12.45	29.63	40.00	-10.37	218	100	QP
2	54.8348	37.63	-11.82	25.81	40.00	-14.19	159	100	QP
3	90.8554	33.56	-12.78	20.78	40.00	-19.22	98	100	QP
4	126.7723	36.70	-14.52	22.18	40.00	-17.82	184	100	QP
5	135.9822	38.41	-15.03	23.38	40.00	-16.62	151	100	QP
6	189.0743	35.63	-12.92	22.71	40.00	-17.29	318	100	QP



5. Harmonic Current Emissions

5.1 Test Procedure

Test is conducted under the description of EN IEC 61000-3-2.

5.2 Test Standards

EN IEC 61000-3-2, Clause 7.2 Limits for Class A equipment.

5.3 Environmental Conditions

Temperature:	23.5 °C
Relative Humidity:	52 %
ATM Pressure:	1013 mbar

5.4 Basic Test Setup Block Diagram

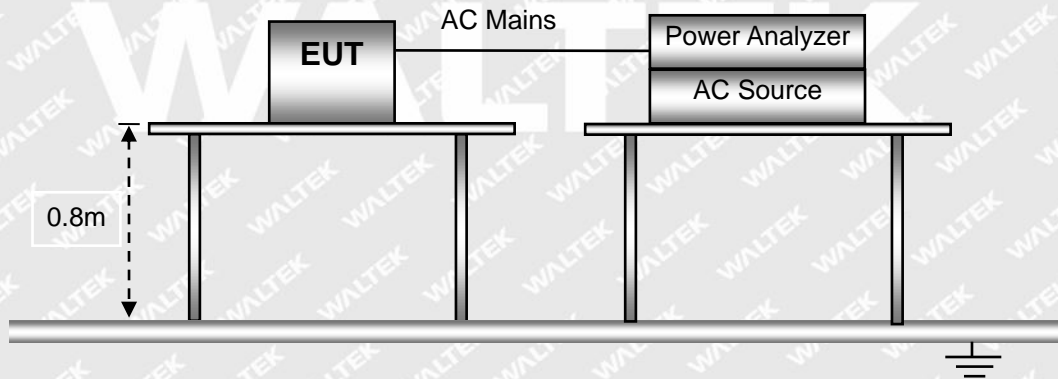

5.5 Harmonic Current Emissions Test Data



GT-46401-4048

Test mode:	TM1
------------	-----

Harmonics – Class-A per IEC 61000-3-2:2018/AMD1:2020(Run time)

Test Result: Pass

Source qualification: Normal

Current & voltage waveforms

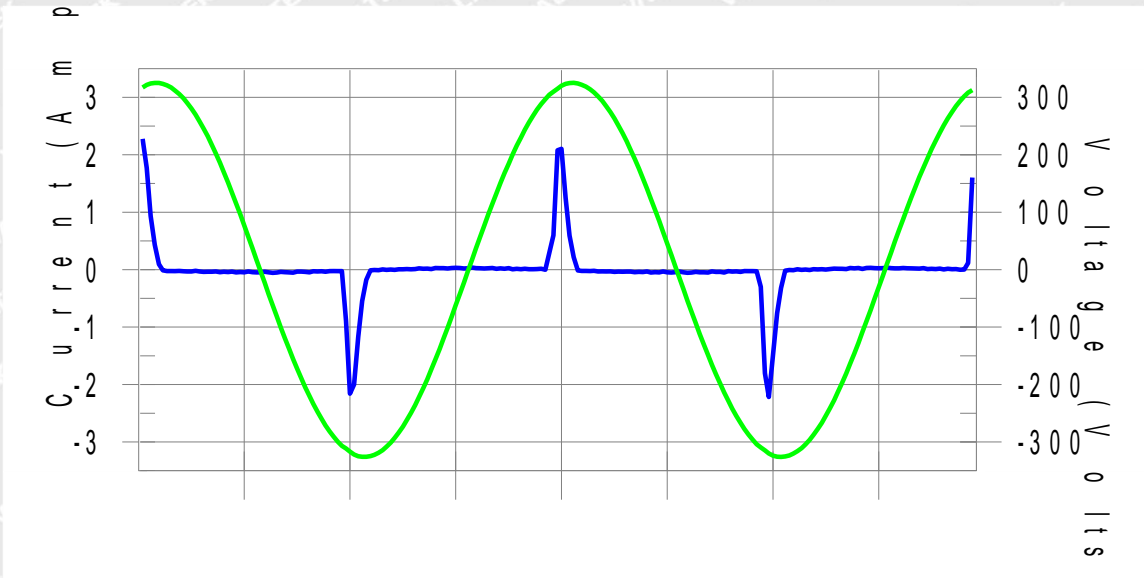

Harmonics and Class A limit line

European Limits

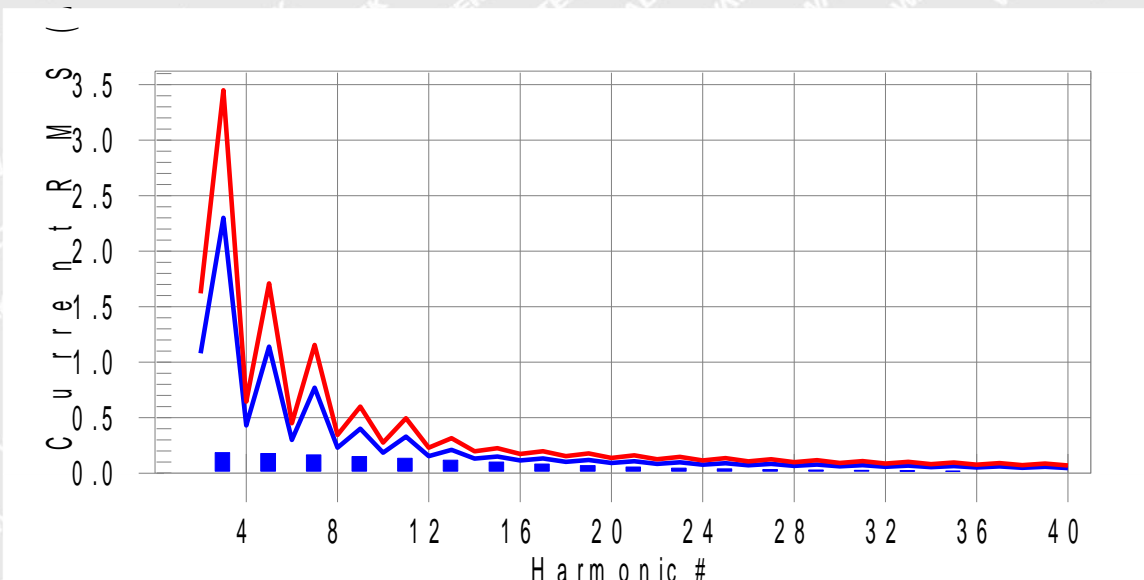

Test result: Pass Worst harmonics H15-44.9% of 150% limit, H15-66.1% of 100% limit



Current Test Result Summary (Run time)

Test Result: Pass Source qualification: Normal
 THC(A): 0.423 I-THD(%): 215.7 POHC(A): 0.102 POHC Limit(A): 0.251

Highest parameter values during test:

V_RMS (Volts): 230.16	Frequency(Hz): 50.00
I_Peak (Amps): 2.302	I_RMS (Amps): 0.468
I_Fund (Amps): 0.196	Crest Factor: 4.931
Power (Watts): 43.1	Power Factor: 0.404

Harm#	Harms(avg)	100%Limit	%of Limit	Harms(max)	150%Limit	%of Limit	Status
2	0.001	1.080	N/A	0.002	1.620	N/A	Pass
3	0.185	2.300	8.1	0.187	3.450	5.4	Pass
4	0.001	0.430	N/A	0.002	0.645	N/A	Pass
5	0.177	1.140	15.5	0.177	1.710	10.4	Pass
6	0.001	0.300	N/A	0.002	0.450	N/A	Pass
7	0.165	0.770	21.4	0.166	1.155	14.3	Pass
8	0.001	0.230	N/A	0.002	0.345	N/A	Pass
9	0.150	0.400	37.6	0.151	0.600	25.2	Pass
10	0.001	0.184	N/A	0.002	0.276	N/A	Pass
11	0.134	0.330	40.6	0.135	0.495	27.3	Pass
12	0.001	0.153	N/A	0.002	0.230	N/A	Pass
13	0.117	0.210	55.5	0.118	0.315	37.5	Pass
14	0.002	0.131	N/A	0.002	0.197	N/A	Pass
15	0.099	0.150	66.1	0.101	0.225	44.9	Pass
16	0.002	0.115	N/A	0.003	0.173	N/A	Pass
17	0.083	0.132	62.6	0.085	0.198	42.8	Pass
18	0.002	0.102	N/A	0.003	0.153	N/A	Pass
19	0.068	0.118	57.3	0.070	0.178	39.5	Pass
20	0.002	0.092	N/A	0.003	0.138	N/A	Pass
21	0.055	0.107	51.7	0.058	0.161	35.9	Pass
22	0.002	0.084	N/A	0.003	0.125	N/A	Pass
23	0.046	0.098	46.7	0.048	0.147	32.5	Pass
24	0.002	0.077	N/A	0.002	0.115	N/A	Pass
25	0.038	0.090	42.7	0.040	0.135	29.8	Pass
26	0.001	0.071	N/A	0.002	0.107	N/A	Pass
27	0.033	0.083	39.8	0.035	0.125	27.7	Pass
28	0.001	0.066	N/A	0.002	0.099	N/A	Pass
29	0.029	0.078	37.4	0.030	0.116	25.8	Pass
30	0.001	0.061	N/A	0.002	0.092	N/A	Pass
31	0.025	0.073	34.9	0.026	0.109	23.9	Pass



Reference No.: WTX22X07139237E

32	0.001	0.058	N/A	0.001	0.086	N/A	Pass
33	0.022	0.068	31.7	0.022	0.102	21.6	Pass
34	0.001	0.054	N/A	0.001	0.081	N/A	Pass
35	0.018	0.064	27.7	0.018	0.096	18.9	Pass
36	0.000	0.051	N/A	0.001	0.077	N/A	Pass
37	0.014	0.061	23.1	0.014	0.091	15.8	Pass
38	0.000	0.048	N/A	0.001	0.073	N/A	Pass
39	0.011	0.058	18.5	0.011	0.087	12.7	Pass
40	0.000	0.046	N/A	0.001	0.069	N/A	Pass

WALTEK



Voltage Source Verification Data (Run time)

Test Result: Pass

Source qualification: Normal

Highest parameter values during test:

Voltage (Vrms):	230.16	Frequency(Hz):	50.00
I_Peak (Amps):	2.302	I_RMS (Amps):	0.468
I_Fund (Amps):	0.196	Crest Factor:	4.931
Power (Watts):	43.1	Power Factor:	0.404

Harm#	Harmonics V-rms	Limit V-rms	% of Limit	Status
2	0.059	0.460	12.90	OK
3	0.540	2.071	26.09	OK
4	0.080	0.460	17.37	OK
5	0.073	0.920	7.91	OK
6	0.036	0.460	7.88	OK
7	0.080	0.690	11.61	OK
8	0.017	0.460	3.64	OK
9	0.088	0.460	19.03	OK
10	0.007	0.460	1.61	OK
11	0.093	0.230	40.52	OK
12	0.011	0.230	4.75	OK
13	0.087	0.230	37.63	OK
14	0.009	0.230	4.10	OK
15	0.088	0.230	38.35	OK
16	0.011	0.230	4.58	OK
17	0.071	0.230	30.79	OK
18	0.008	0.230	3.49	OK
19	0.071	0.230	30.92	OK
20	0.018	0.230	7.63	OK
21	0.060	0.230	26.20	OK
22	0.006	0.230	2.78	OK
23	0.054	0.230	23.39	OK
24	0.004	0.230	1.83	OK
25	0.048	0.230	20.71	OK
26	0.004	0.230	1.90	OK
27	0.048	0.230	20.81	OK
28	0.005	0.230	2.31	OK
29	0.038	0.230	16.53	OK
30	0.006	0.230	2.39	OK
31	0.037	0.230	16.27	OK
32	0.003	0.230	1.47	OK



Reference No.: WTX22X07139237E

33	0.035	0.230	15.00	OK
34	0.004	0.230	1.55	OK
35	0.030	0.230	13.04	OK
36	0.003	0.230	1.50	OK
37	0.027	0.230	11.95	OK
38	0.003	0.230	1.42	OK
39	0.023	0.230	9.99	OK
40	0.008	0.230	3.38	OK

WALTEK



GT-46401-3612

Test mode:	TM2
------------	-----

Harmonics – Class-A per IEC 61000-3-2:2018/AMD1:2020(Run time)

Test Result: Pass

Source qualification: Normal

Current & voltage waveforms

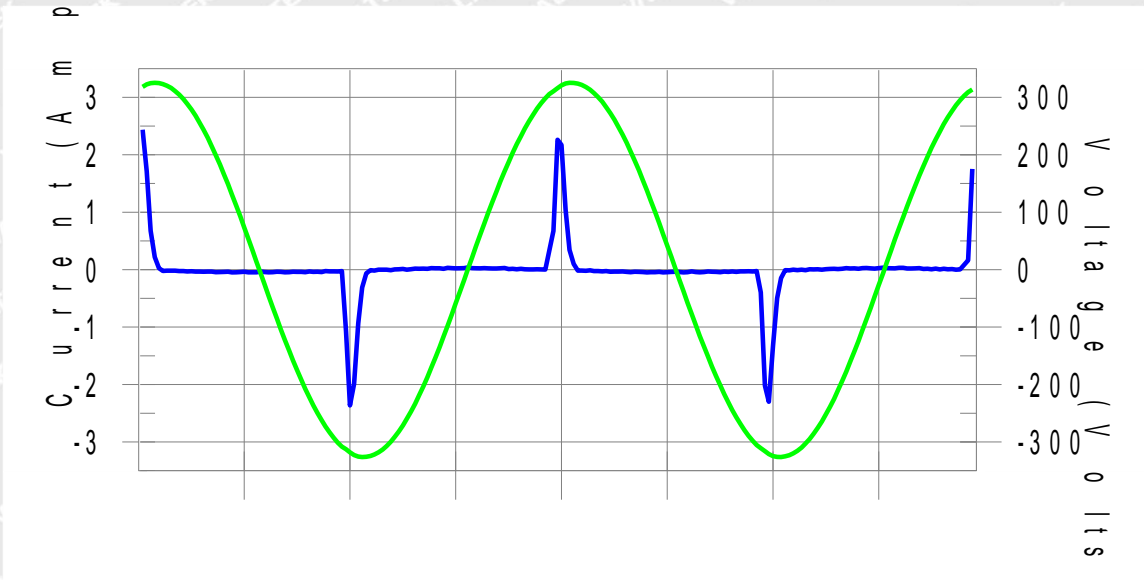

Harmonics and Class A limit line European Limits

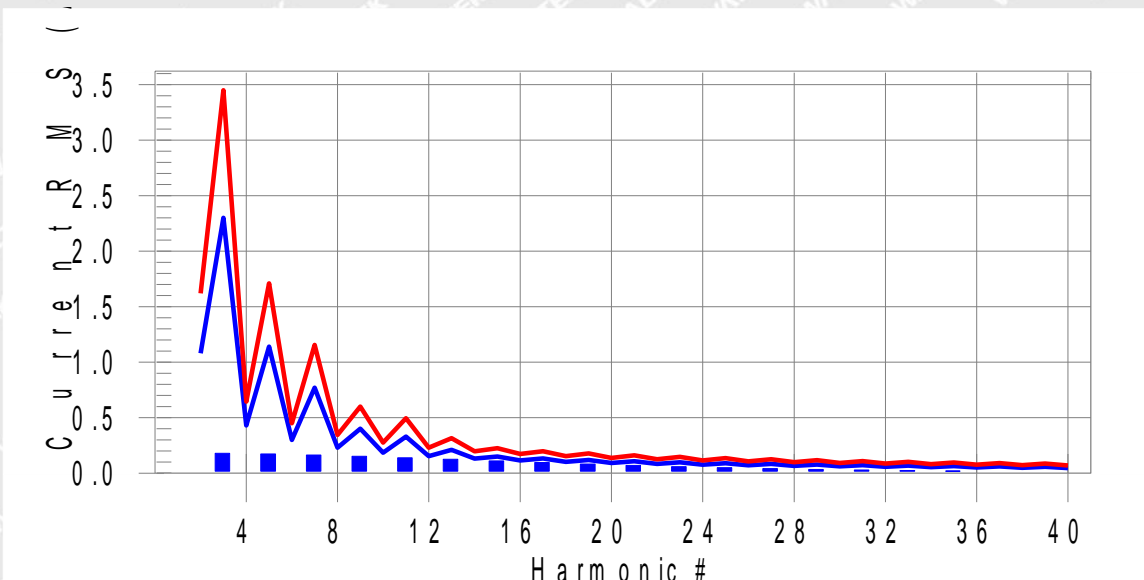

Test result: Pass Worst harmonics H15-49.4% of 150% limit, H15-73.6% of 100% limit



Current Test Result Summary (Run time)

Test Result: Pass Source qualification: Normal
 THC(A): 0.436 I-THD(%): 232.0 POHC(A): 0.125 POHC Limit(A): 0.251

Highest parameter values during test:

V_RMS (Volts): 230.16	Frequency(Hz): 50.00
I_Peak (Amps): 2.458	I_RMS (Amps): 0.476
I_Fund (Amps): 0.188	Crest Factor: 5.177
Power (Watts): 41.3	Power Factor: 0.380

Harm#	Harms(avg)	100%Limit	%of Limit	Harms(max)	150%Limit	%of Limit	Status
2	0.001	1.080	N/A	0.002	1.620	N/A	Pass
3	0.179	2.300	7.8	0.180	3.450	5.2	Pass
4	0.001	0.430	N/A	0.002	0.645	N/A	Pass
5	0.172	1.140	15.1	0.173	1.710	10.1	Pass
6	0.001	0.300	N/A	0.002	0.450	N/A	Pass
7	0.163	0.770	21.2	0.164	1.155	14.2	Pass
8	0.001	0.230	N/A	0.002	0.345	N/A	Pass
9	0.152	0.400	38.0	0.152	0.600	25.4	Pass
10	0.001	0.184	N/A	0.002	0.276	N/A	Pass
11	0.139	0.330	42.1	0.139	0.495	28.2	Pass
12	0.002	0.153	N/A	0.002	0.230	N/A	Pass
13	0.125	0.210	59.5	0.126	0.315	39.8	Pass
14	0.002	0.131	N/A	0.003	0.197	N/A	Pass
15	0.110	0.150	73.6	0.111	0.225	49.4	Pass
16	0.002	0.115	N/A	0.003	0.173	N/A	Pass
17	0.096	0.132	72.7	0.097	0.198	48.8	Pass
18	0.002	0.102	N/A	0.003	0.153	N/A	Pass
19	0.082	0.118	69.5	0.083	0.178	46.8	Pass
20	0.002	0.092	N/A	0.003	0.138	N/A	Pass
21	0.070	0.107	65.1	0.071	0.161	43.9	Pass
22	0.002	0.084	N/A	0.003	0.125	N/A	Pass
23	0.059	0.098	59.9	0.059	0.147	40.4	Pass
24	0.002	0.077	N/A	0.003	0.115	N/A	Pass
25	0.049	0.090	54.4	0.050	0.135	36.7	Pass
26	0.002	0.071	N/A	0.003	0.107	N/A	Pass
27	0.041	0.083	49.1	0.041	0.125	33.1	Pass
28	0.002	0.066	N/A	0.002	0.099	N/A	Pass
29	0.034	0.078	43.9	0.034	0.116	29.6	Pass
30	0.001	0.061	N/A	0.002	0.092	N/A	Pass
31	0.028	0.073	39.0	0.029	0.109	26.3	Pass



Reference No.: WTX22X07139237E

32	0.001	0.058	N/A	0.002	0.086	N/A	Pass
33	0.023	0.068	34.2	0.024	0.102	23.0	Pass
34	0.001	0.054	N/A	0.001	0.081	N/A	Pass
35	0.019	0.064	29.4	0.019	0.096	19.8	Pass
36	0.001	0.051	N/A	0.001	0.077	N/A	Pass
37	0.015	0.061	24.7	0.015	0.091	16.7	Pass
38	0.000	0.048	N/A	0.001	0.073	N/A	Pass
39	0.012	0.058	20.3	0.012	0.087	13.7	Pass
40	0.000	0.046	N/A	0.001	0.069	N/A	Pass

WALTEK



Voltage Source Verification Data (Run time)

Test Result: Pass

Source qualification: Normal

Highest parameter values during test:

Voltage (Vrms):	230.16	Frequency(Hz):	50.00
I_Peak (Amps):	2.458	I_RMS (Amps):	0.476
I_Fund (Amps):	0.188	Crest Factor:	5.177
Power (Watts):	41.3	Power Factor:	0.380

Harm#	Harmonics V-rms	Limit V-rms	% of Limit	Status
2	0.065	0.460	14.20	OK
3	0.527	2.071	25.43	OK
4	0.076	0.460	16.50	OK
5	0.071	0.920	7.75	OK
6	0.033	0.460	7.23	OK
7	0.077	0.690	11.19	OK
8	0.016	0.460	3.47	OK
9	0.086	0.460	18.66	OK
10	0.008	0.460	1.79	OK
11	0.097	0.230	41.94	OK
12	0.011	0.230	4.72	OK
13	0.090	0.230	39.13	OK
14	0.010	0.230	4.27	OK
15	0.098	0.230	42.61	OK
16	0.010	0.230	4.52	OK
17	0.081	0.230	35.37	OK
18	0.008	0.230	3.32	OK
19	0.085	0.230	37.08	OK
20	0.018	0.230	7.69	OK
21	0.075	0.230	32.63	OK
22	0.006	0.230	2.73	OK
23	0.068	0.230	29.53	OK
24	0.004	0.230	1.91	OK
25	0.060	0.230	26.04	OK
26	0.005	0.230	2.01	OK
27	0.058	0.230	25.06	OK
28	0.007	0.230	2.92	OK
29	0.044	0.230	19.32	OK
30	0.005	0.230	2.10	OK
31	0.042	0.230	18.16	OK
32	0.004	0.230	1.74	OK



Reference No.: WTX22X07139237E

33	0.036	0.230	15.53	OK
34	0.003	0.230	1.50	OK
35	0.033	0.230	14.14	OK
36	0.003	0.230	1.27	OK
37	0.029	0.230	12.40	OK
38	0.003	0.230	1.39	OK
39	0.025	0.230	10.88	OK
40	0.008	0.230	3.33	OK

WALTEK



6. Voltage Fluctuation Flicker

6.1 Test Procedure

Test is conducted under the description of EN 61000-3-3.

6.2 Test Standards

EN 61000-3-3, Limit: Clause 5.

6.3 Environmental Conditions

Temperature:	23.5 °C
Relative Humidity:	52 %
ATM Pressure:	1013 mbar

6.4 Basic Test Setup Block Diagram

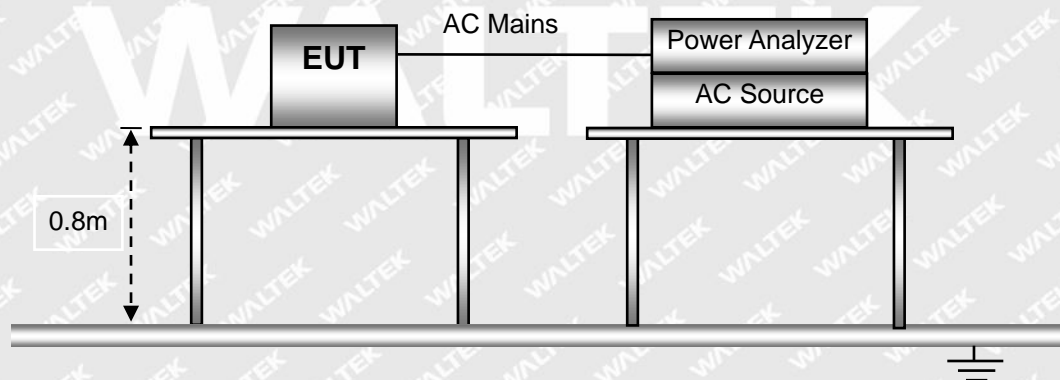

6.5 Voltage Fluctuation and Flicker Test Data



GT-46401-4048

Test mode:	TM1
------------	-----

Flicker Test Summary per IEC61000-3-3:2013/AMD1:2017 (Run time)

Test Result: Pass

Status: Test Completed

Pst and limit line

European Limits



Plt and limit line



Parameter values recorded during the test:

Vrms at the end of test (Volt):	230.08		
Highest dt (%):		Test limit (%):	
T-max (mS):	0	Test limit (mS):	500.0 Pass
Highest dc (%):	0.00	Test limit (%):	3.30 Pass
Highest dmax (%):	0.00	Test limit (%):	4.00 Pass
Highest Pst (10 min. period):	0.247	Test limit:	1.000 Pass
Highest Plt (2 hr. period):	0.108	Test limit:	0.650 Pass



GT-46401-3612

Test mode:	TM2
------------	-----

Flicker Test Summary per IEC61000-3-3:2013/AMD1:2017 (Run time)

Test Result: Pass

Status: Test Completed

Pst and limit line

European Limits



Plt and limit line



Parameter values recorded during the test:

Vrms at the end of test (Volt):	230.12		
Highest dt (%):		Test limit (%):	
T-max (mS):	0	Test limit (mS):	500.0 Pass
Highest dc (%):	0.00	Test limit (%):	3.30 Pass
Highest dmax (%):	0.00	Test limit (%):	4.00 Pass
Highest Pst (10 min. period):	0.244	Test limit:	1.000 Pass
Highest Plt (2 hr. period):	0.107	Test limit:	0.650 Pass



7. Electrostatic Discharges (ESD)

7.1 Test Procedure

Test is conducted under the description of EN 61000-4-2.

7.2 Test Performance

Performance Criterion: B

7.3 Environmental Conditions

Temperature:	20.5 °C
Relative Humidity:	47 %
ATM Pressure:	1012 mbar

7.4 Basic Test Setup Block Diagram

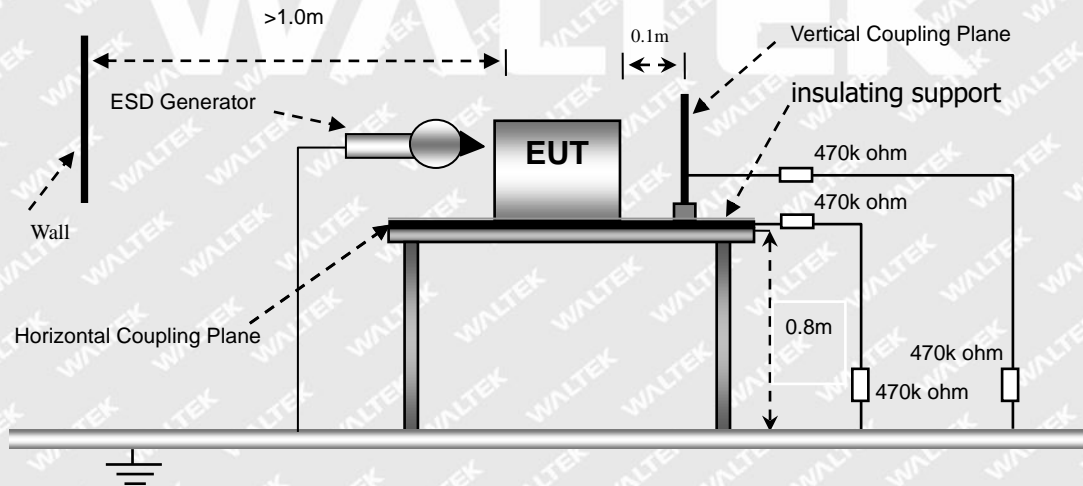



7.5 Electrostatic Discharge Immunity Test Data

Table 1: Electrostatic Discharge Immunity (Air Discharge)

EN 61000-4-2 Test Points	Test Voltage (kV)									
	-2	+2	-4	+4	-6	+6	-8	+8	-15	+15
shell	A	A	A	A	A	A	A	A	/	/
gap	A	A	A	A	A	A	A	A	/	/

Table 2: Electrostatic Discharge Immunity (Direct Contact)

EN 61000-4-2 Test Points	Test Voltage (kV)									
	-2	+2	-4	+4	-6	+6	-8	+8	-15	+15
Output port	A	A	A	A	/	/	/	/	/	/

Table 3: Electrostatic Discharge Immunity (Indirect Contact HCP & VCP)

EN 61000-4-2 Test Points	Test Voltage (kV)									
	-2	+2	-4	+4	-6	+6	-8	+8	-15	+15
HCP (6 Sides)	A	A	A	A	/	/	/	/	/	/
VCP (4 Sides)	A	A	A	A	/	/	/	/	/	/

Test Result: Pass



8. Continuous RF Electromagnetic Field Disturbances (RS)

8.1 Test Procedure

Test is conducted under the description of EN 61000-4-3.

8.2 Test Performance

Performance Criterion: A

8.3 Environmental Conditions

Temperature:	23.0 °C
Relative Humidity:	54 %
ATM Pressure:	1011 mbar

8.4 Basic Test Setup Block Diagram

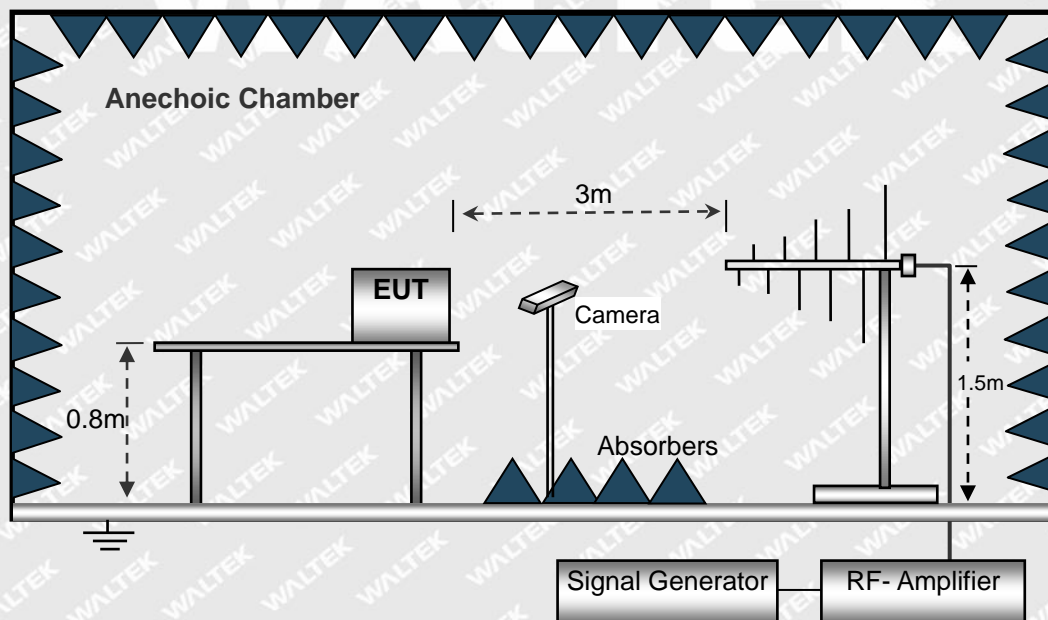



8.5 Continuous Radiated Disturbances Test Data

Frequency step: 1% of fundamental

Dwell time: 1 second

Modulation: AM by 1kHz sine wave with 80% modulation depth

Frequency Range(MHz)	Field (V/m)	Front		Rear		Left Side		Right Side	
		VERT	HORI	VERT	HORI	VERT	HORI	VERT	HORI
80-1000	3	A	A	A	A	A	A	A	A

Spot frequencies (MHz)	Field (V/m)	Front		Rear		Left Side		Right Side	
		VERT	HORI	VERT	HORI	VERT	HORI	VERT	HORI
1800	3	A	A	A	A	A	A	A	A
2600	3	A	A	A	A	A	A	A	A
3500	3	A	A	A	A	A	A	A	A
5000	3	A	A	A	A	A	A	A	A

Test Result: Pass



9. Electrical Fast Transients (EFT)

9.1 Test Procedure

Test is conducted under the description of EN 61000-4-4.

9.2 Test Performance

Performance Criterion: B

9.3 Environmental Conditions

Temperature:	23.5 °C
Relative Humidity:	51 %
ATM Pressure:	1011 mbar

9.4 Basic Test Setup Block Diagram

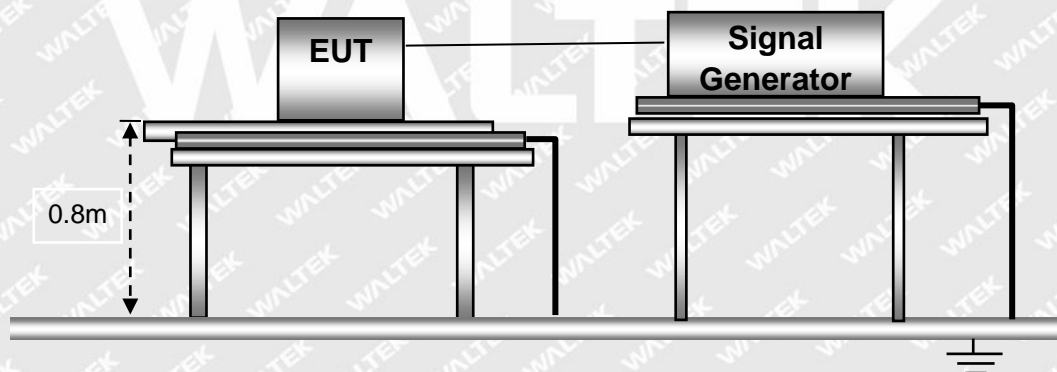



9.5 Electrical Fast Transients Test Data

EN 61000-4-4 Test Points		Test Voltage (kV)							
		+0.5	-0.5	+1.0	-1.0	+2.0	-2.0	+4.0	-4.0
Power Supply Power Port of EUT	L1	/	/	A	A	/	/	/	/
	L2	/	/	A	A	/	/	/	/
	PE	/	/	/	/	/	/	/	/
	L1+L2	/	/	A	A	/	/	/	/
	L1 + PE	/	/	/	/	/	/	/	/
	L2 + PE	/	/	/	/	/	/	/	/
	L1+L2+PE	/	/	/	/	/	/	/	/
Signal ports	RJ45	/	/	/	/	/	/	/	/

Test Result: Pass

WALTEK



10. Surges

10.1 Test Procedure

Test is conducted under the description of EN 61000-4-5.

10.2 Test Performance

Performance Criterion: B

10.3 Environmental Conditions

Temperature:	24 °C
Relative Humidity:	51 %
ATM Pressure:	1013 mbar

10.4 Basic Test Setup Block Diagram

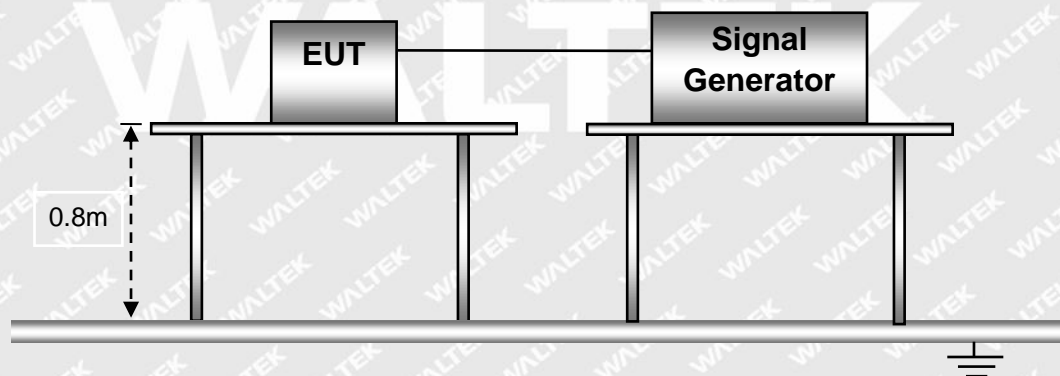



10.5 Surge Test Data

AC Port

Test Voltage (kV)	Poll	Path	Pass	Fail
0.5kV	±	L-N	/	/
1kV	±	L-N	A	/
2kV	±	L-PE, N-PE	/	/
4kV	±	L-N, L-PE, N-PE	/	/

Test Result: Pass

WALTEK



11. Continuous Induced RF Disturbances (C/S)

11.1 Test Procedure

Test is conducted under the description of EN 61000-4-6.

11.2 Test Performance

Performance Criterion: A

11.3 Environmental Conditions

Temperature:	23.5 °C
Relative Humidity:	53 %
ATM Pressure:	1013 mbar

11.4 Basic Test Setup Block Diagram

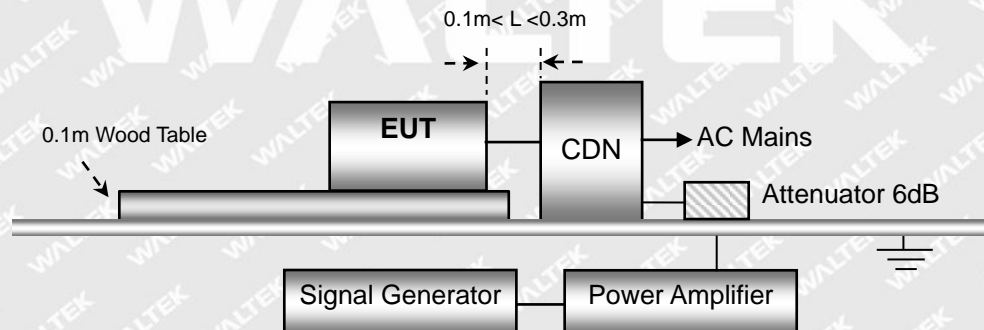



11.5 Continuous Conducted Disturbances Test Data

Sweep frequency range: 0.15MHz to 10MHz 3V; 10MHz to 30MHz 3V to 1V; 30MHz to 80MHz 1V

Frequency step: 1% of fundamental

Dwell time: 1 second

AC Port

Frequency MHz	Injected Position	Voltage level (e.m.f.)	Observations (Performance Criterion)	Result
0.15-10	AC Mains	3V	A	Pass
10-30	AC Mains	3-1V	A	Pass
30-80	AC Mains	1V	A	Pass

Test Result: Pass





12. Power-Frequency Magnetic Fields (PFMF)

12.1 Test Procedure

Test is conducted under the description of EN 61000-4-8.

12.2 Test Performance

Performance Criterion: A

12.3 Environmental Conditions

Temperature:	23.0 °C
Relative Humidity:	52 %
ATM Pressure:	1013 mbar

12.4 Basic Test Setup Block Diagram

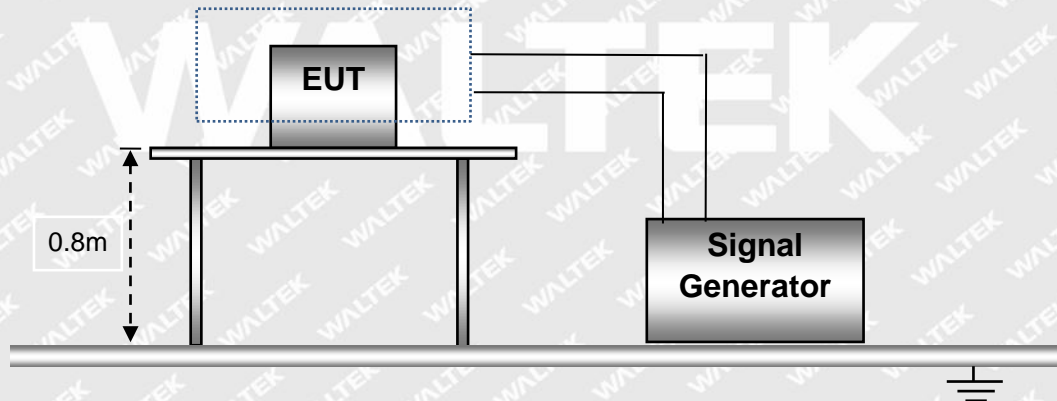



12.5 Power-Frequency Magnetic Field Test Data

Level	Magnetic Field Strength (r.m.s) A/m	Frequency Hz	Induction Coil Position	Pass	Fail
1	1	50	X, Y, Z	A	/
2	3	50	X, Y, Z	/	/
3	10	50	X, Y, Z	/	/
X	Special	/	/	/	/

Test Result: Pass

WALTEK



13. Voltage Dips and Interruptions

13.1 Test Procedure

Test is conducted under the description of EN 61000-4-11.

13.2 Test Performance

Performance Criterion: B/C

13.3 Environmental Conditions

Temperature:	22.5 °C
Relative Humidity:	51 %
ATM Pressure:	1012 mbar

13.4 Basic Test Setup Block Diagram

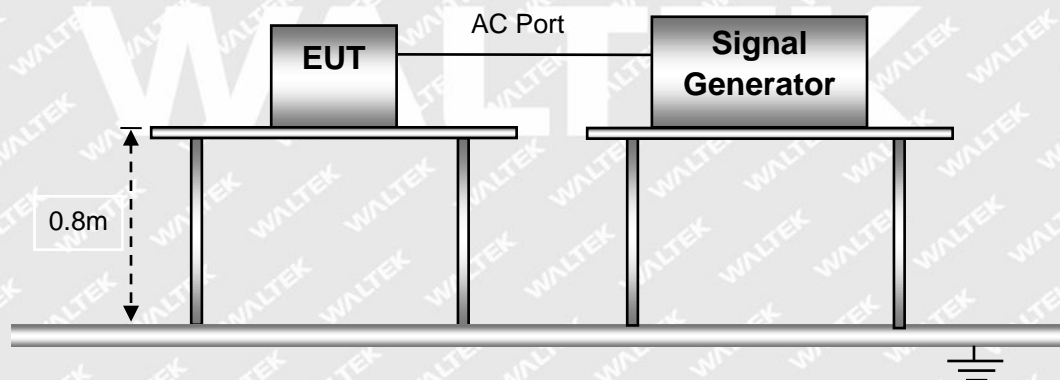



13.5 Voltage Dips And Interruptions Test Data

U: Voltage dips in % U_T (U_T is rated voltage for the EUT)

T: Test duration

Level	U	T	Phase Angle	N	Pass	Fail
1	100%	10ms	0/90/180/270	3	B	/
2	30%	500ms	0/90/180/270	3	B	/
3	100%	5000ms	0/90/180/270	3	B	/



Test Result: Pass

WALTEK



EXHIBIT 1 - PRODUCT LABELING

Proposed CE Label Format

<p>ITE Power Supply Model: GT*46401-**** (Replaceable plug); GT*46401-****-W2Z* (Fixed plug)</p> <p>GlobTek, Inc.</p> <p>Brand: </p> <p>Importer Name: XXX Importer Address: XXX</p> <p>1: GlobTek, Inc. 2: GlobTek (Suzhou) Co., Ltd 1: 186 Veterans Dr. Northvale, NJ 07647 USA 2: Building 4, No. 76, Jin Ling East Rd., Suzhou Industrial Park, Suzhou, JiangSu 215021, China</p>	
--	---

Specifications: Text is Black in color and is justified. Labels are printed in indelible ink on permanent adhesive backing or silk-screened onto the EUT or shall be affixed at a conspicuous location on the EUT. The ‘CE’ marking must be affixed to the EUT or to its data plate. Where this is not possible or not warranted on account of the nature of the apparatus, it must be affixed to the packaging, if any, and to the accompanying documents. The ‘CE’ marking must have a height of at least 5 mm. If the ‘CE’ marking is reduced or enlarged the proportions given in the above graduated drawing must be respected. The Importer name, address and Manufacturer name and address should indicate on marking label or packaging or in a document accompanying.

Proposed Label Location on EUT

CE Label Location

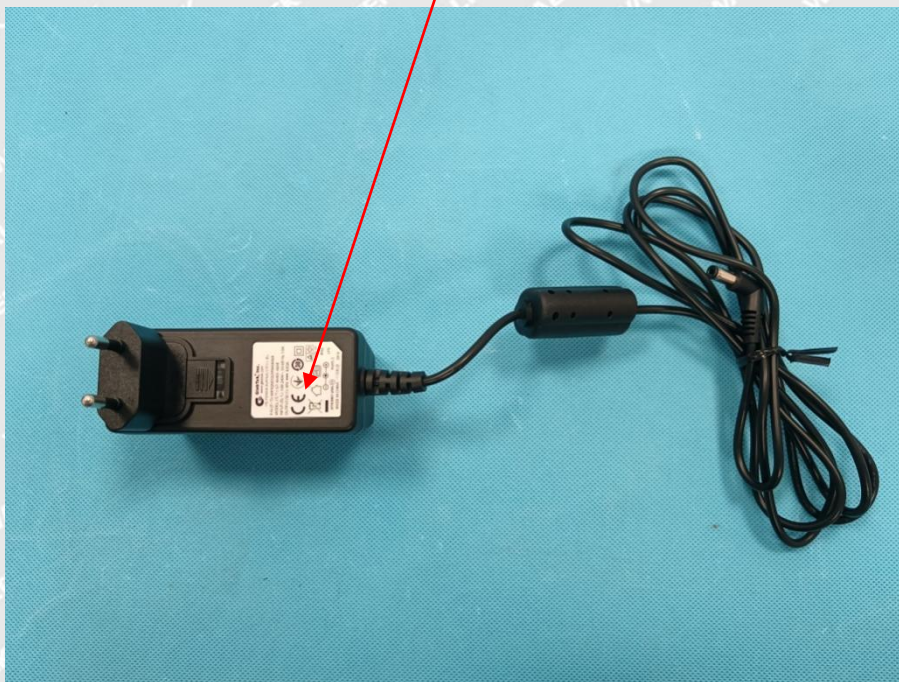
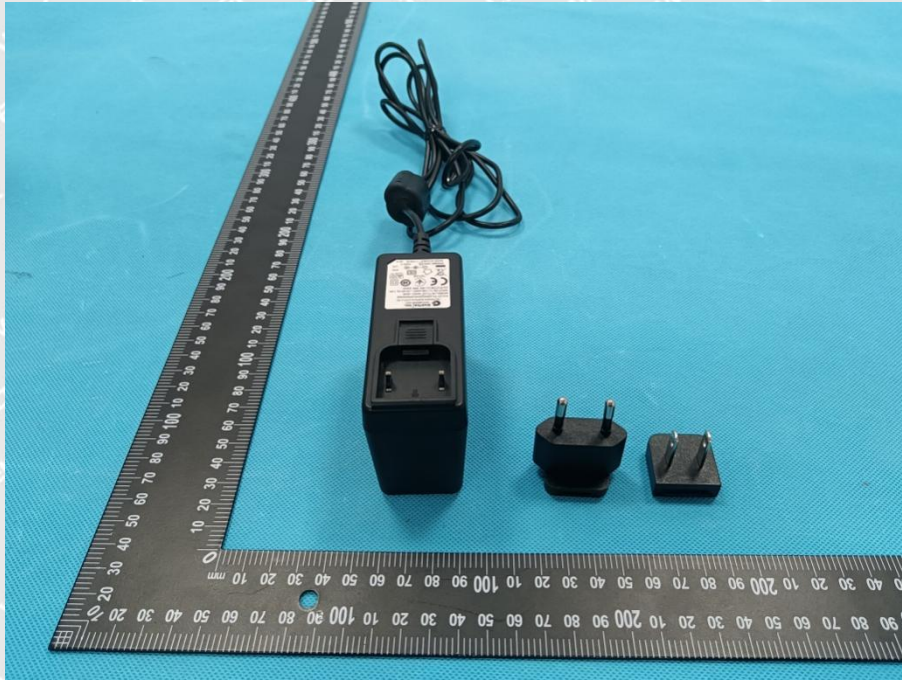



EXHIBIT 2 - EUT PHOTOGRAPHS

GT-46401-4048

EUT View 1



EUT View 2

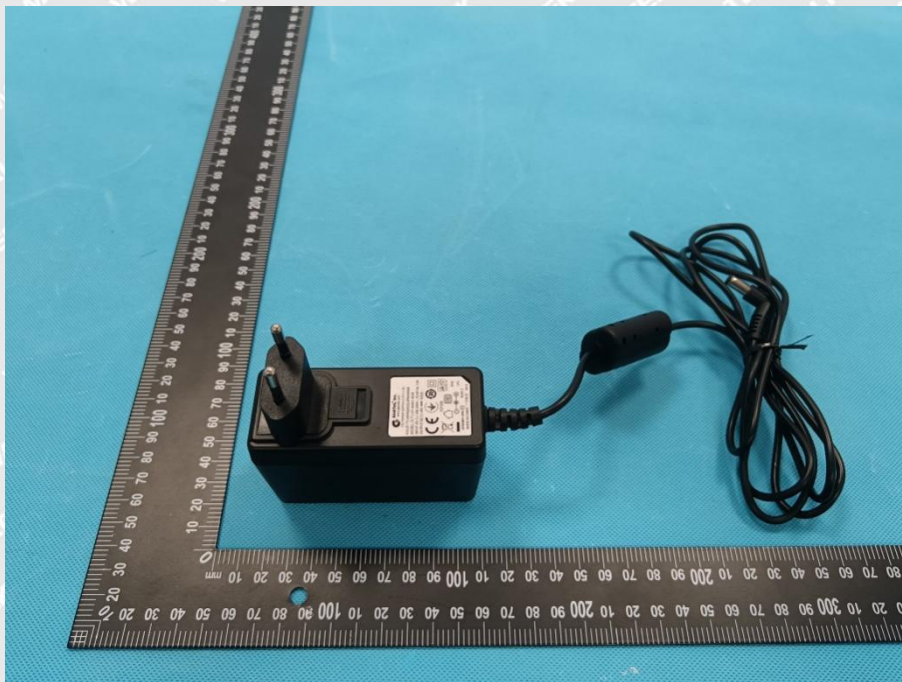



Reference No.: WTX22X07139237E

EUT View 3

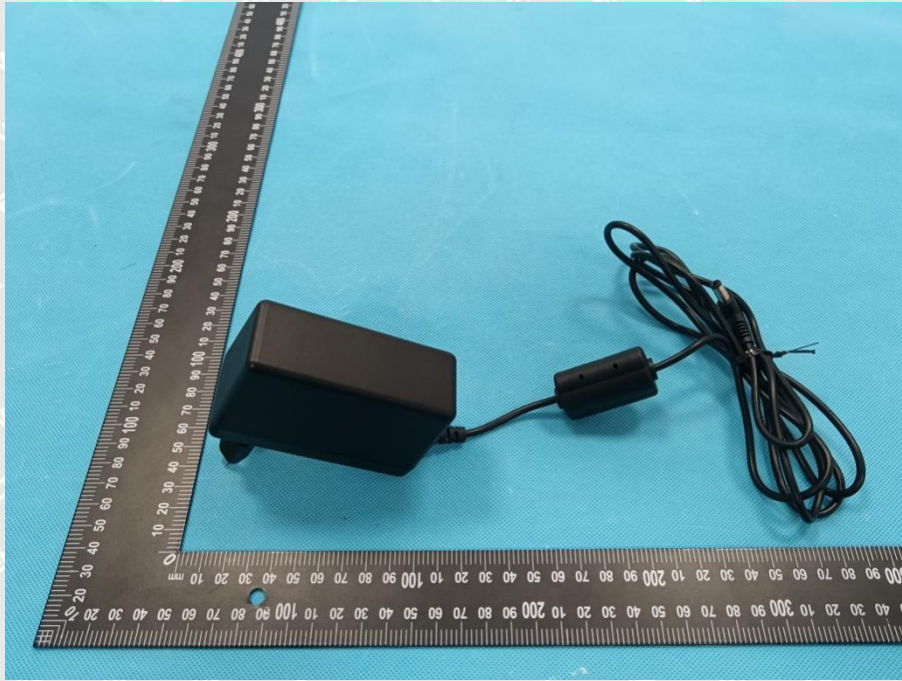

EUT View 4

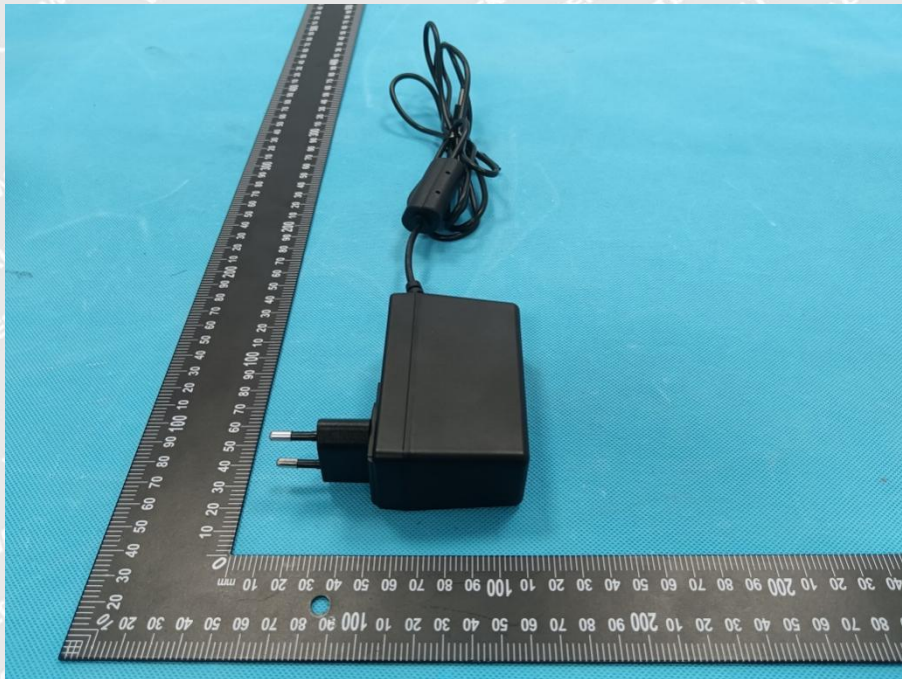



Reference No.: WTX22X07139237E

EUT View 5

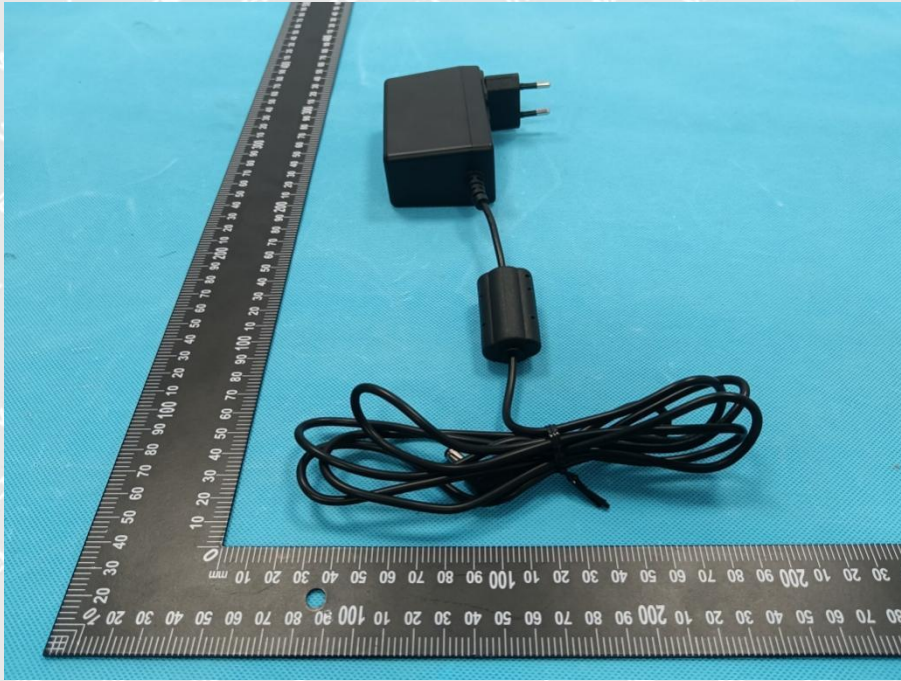

GT-46401-3612
EUT View 1





EUT View 2

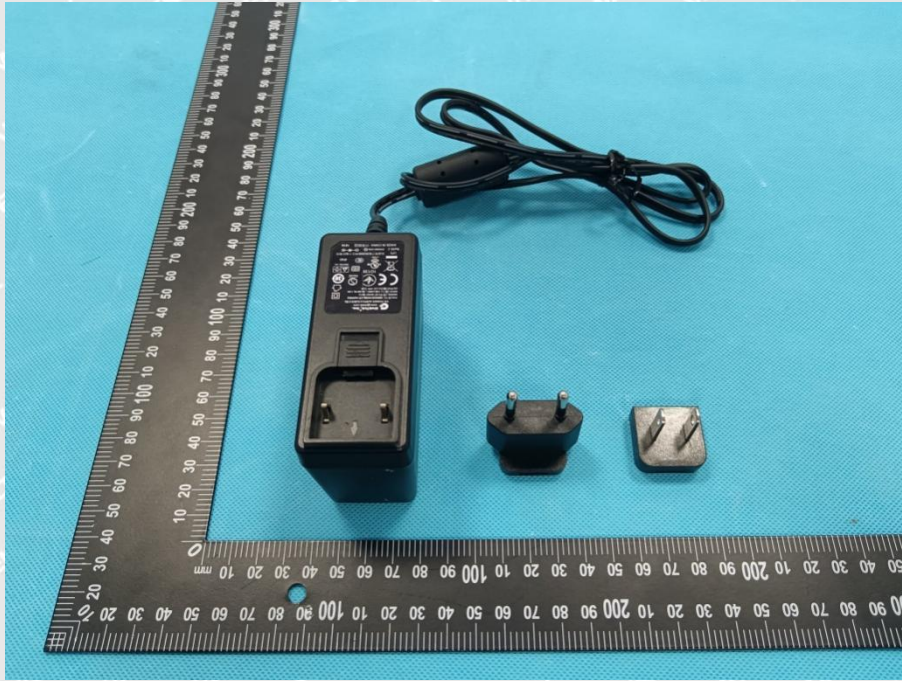

EUT View 3

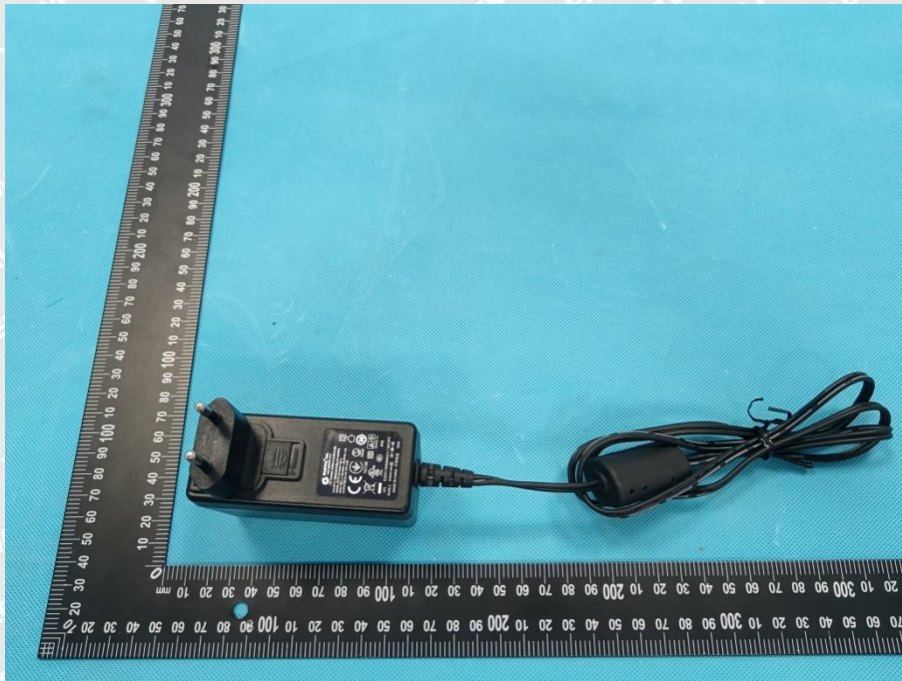



Reference No.: WTX22X07139237E

EUT View 4

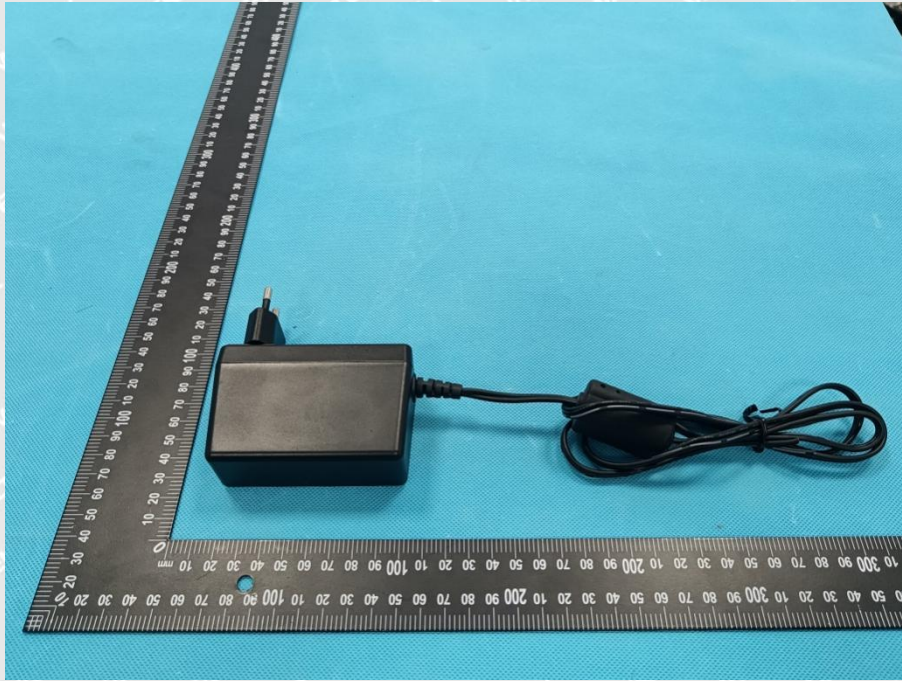

EUT View 5

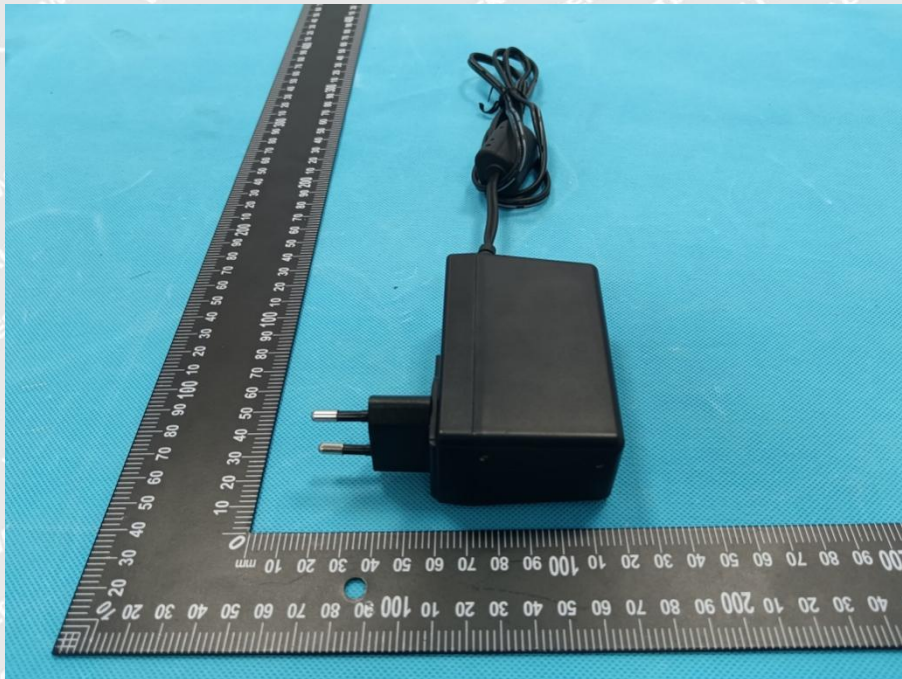



EUT View 6

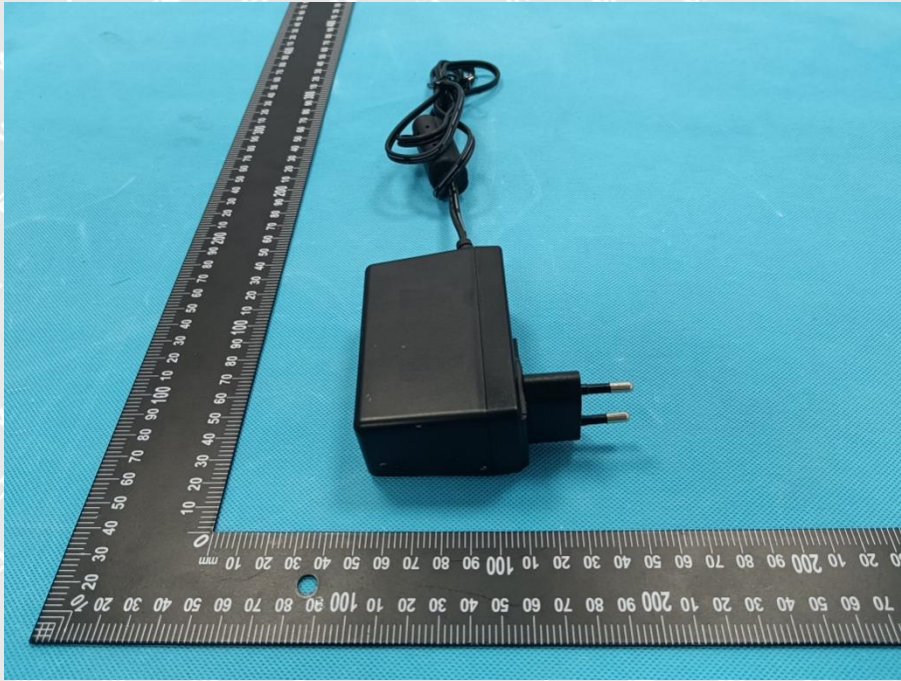

WALTEK



Reference No.: WTX22X07139237E

GT-46401-4048

Solder Board-Component View 1

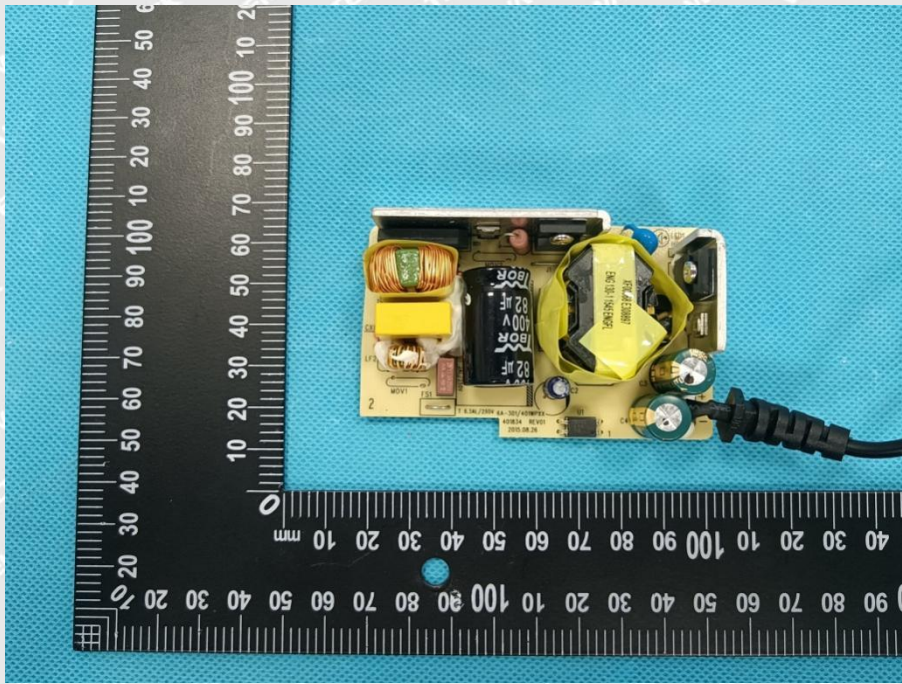

Solder Board-Component View 2

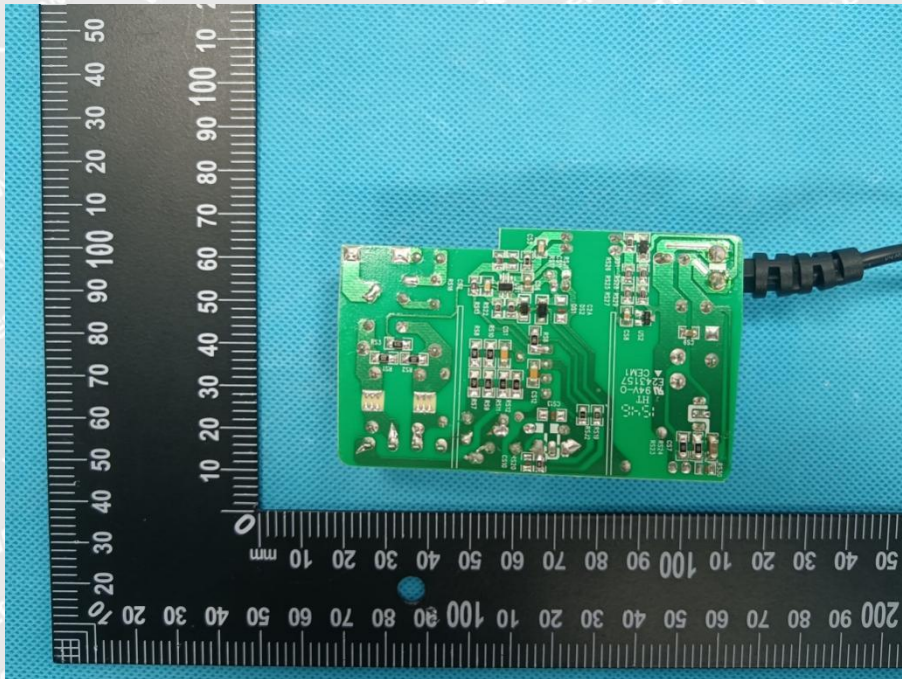



Reference No.: WTX22X07139237E

GT-46401-3612

Solder Board-Component View 1

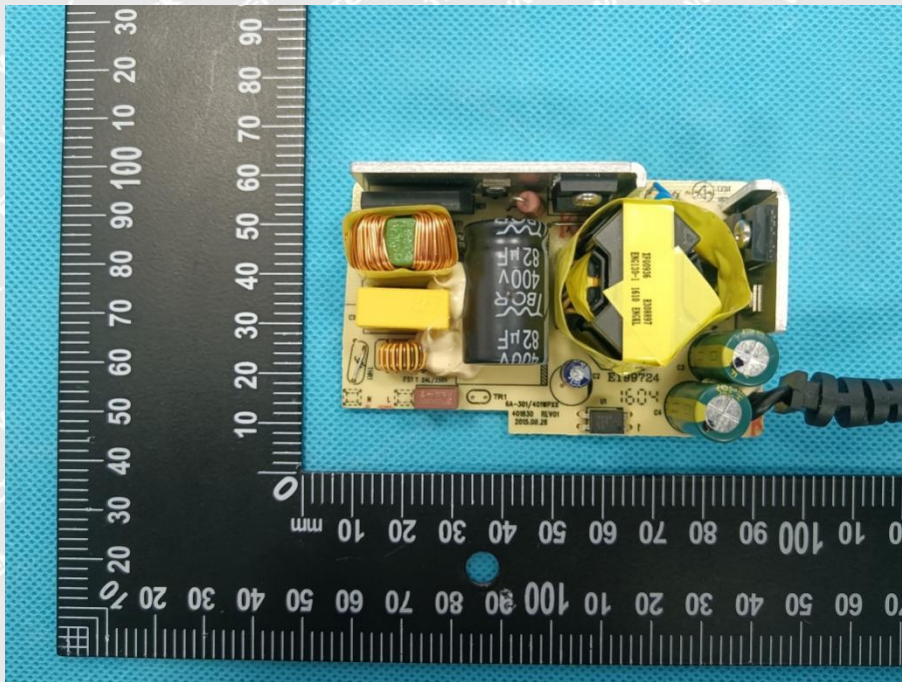

Solder Board-Component View 2

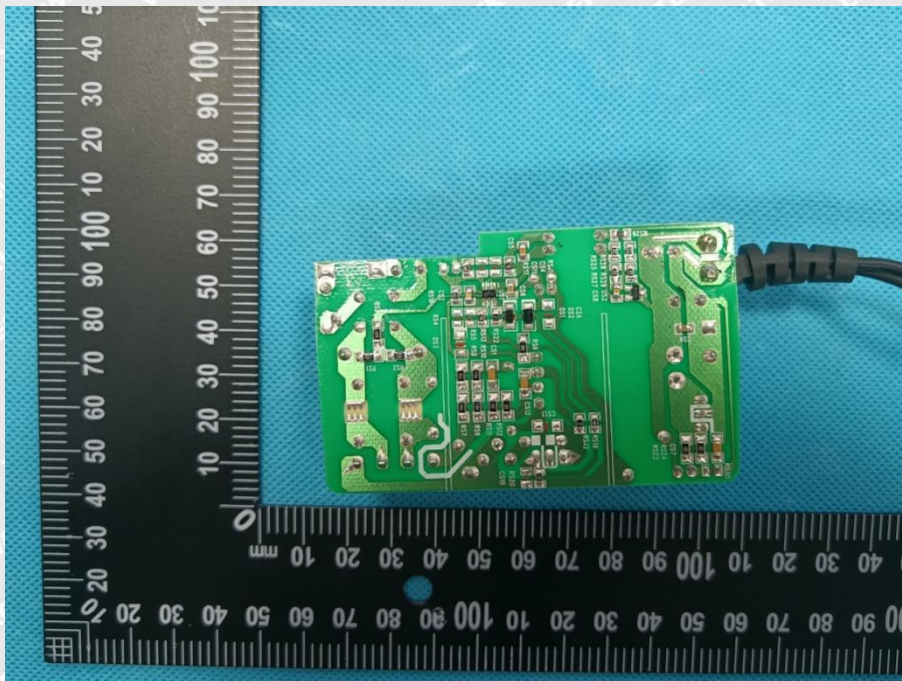



EXHIBIT 3 - TEST SETUP PHOTOGRAPHS

GT-46401-4048

Conduction Emission Test View



Radiation Emission Test View

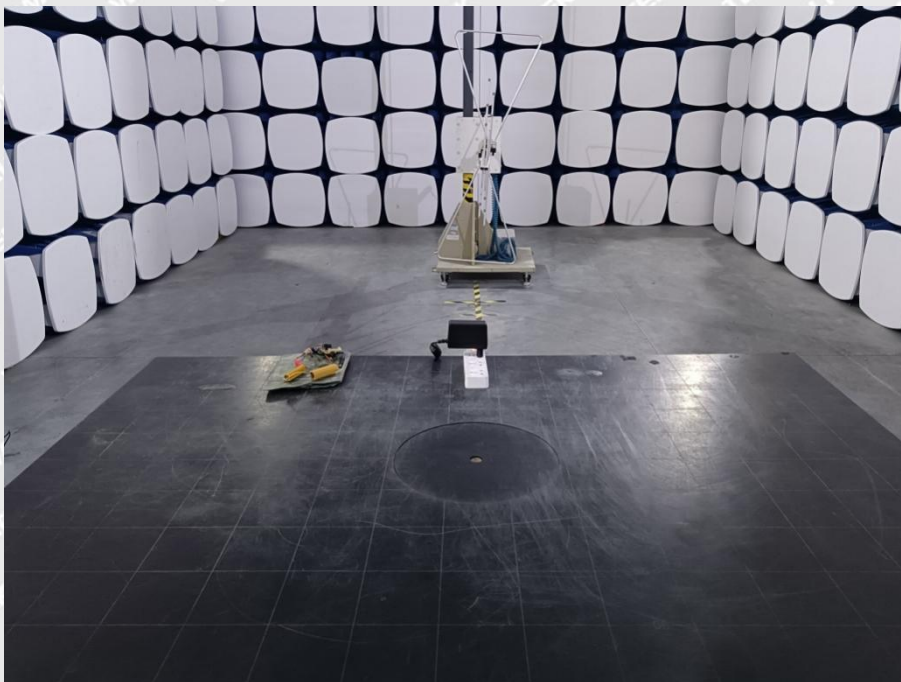



Reference No.: WTX22X07139237E

Harmonic/Flicker Test View



EN 61000-4-2 Test View





Reference No.: WTX22X07139237E

EN 61000-4-3 Test View



EN 61000-4-4/5/11 Test View

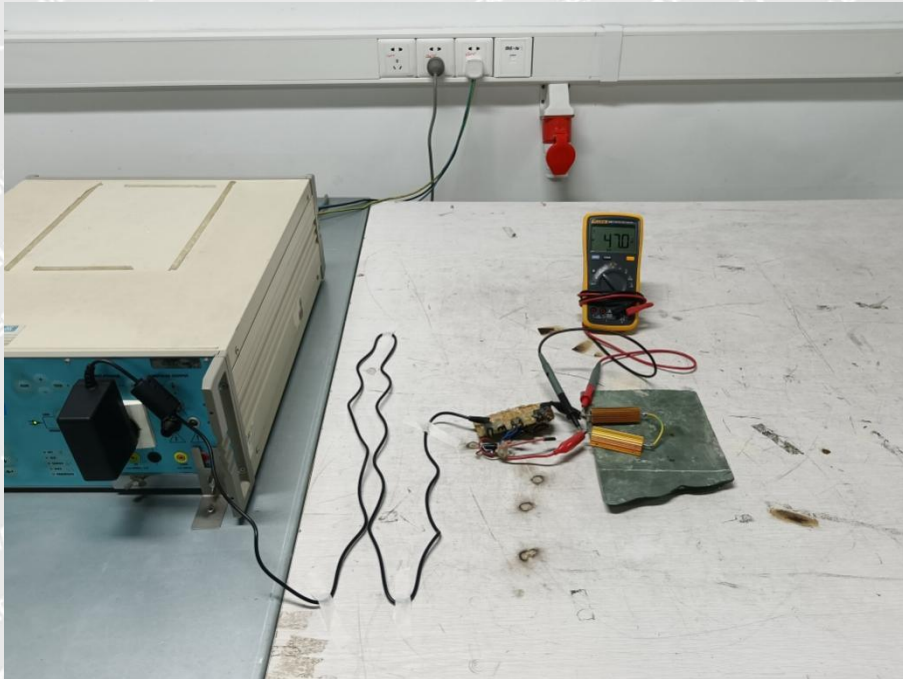



Reference No.: WTX22X07139237E

EN 61000-4-6 Test View

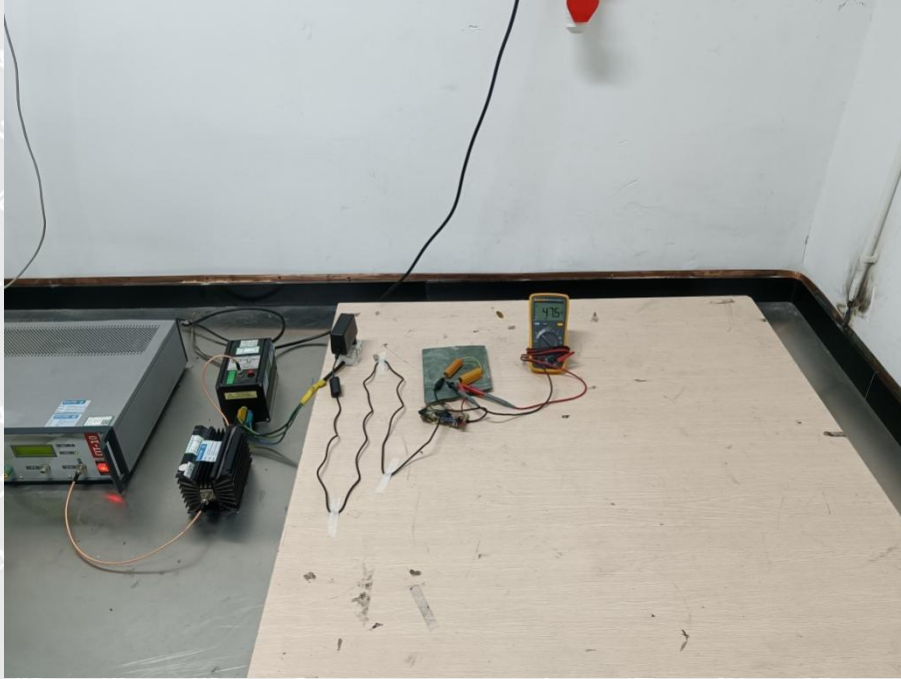

EN 61000-4-8 Test View

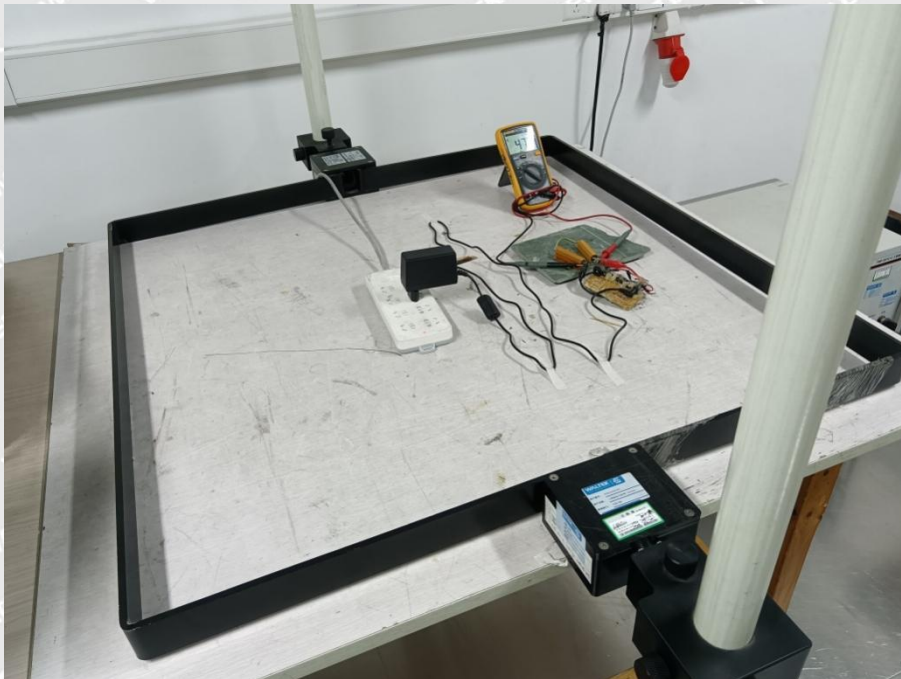



Reference No.: WTX22X07139237E

GT-46401-3612

Conduction Emission Test View

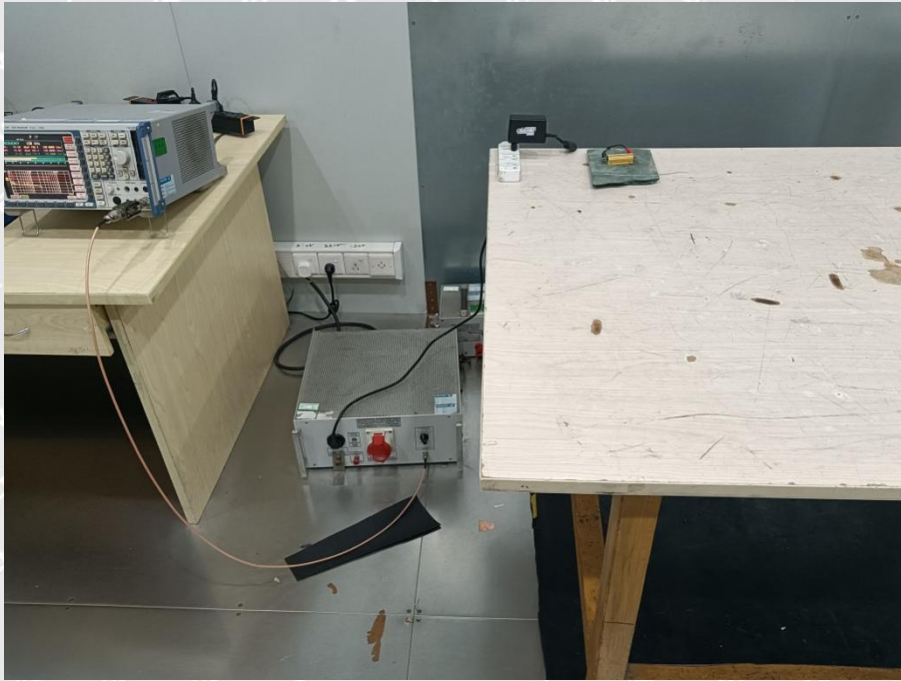

WALTEK

Radiation Emission Test View

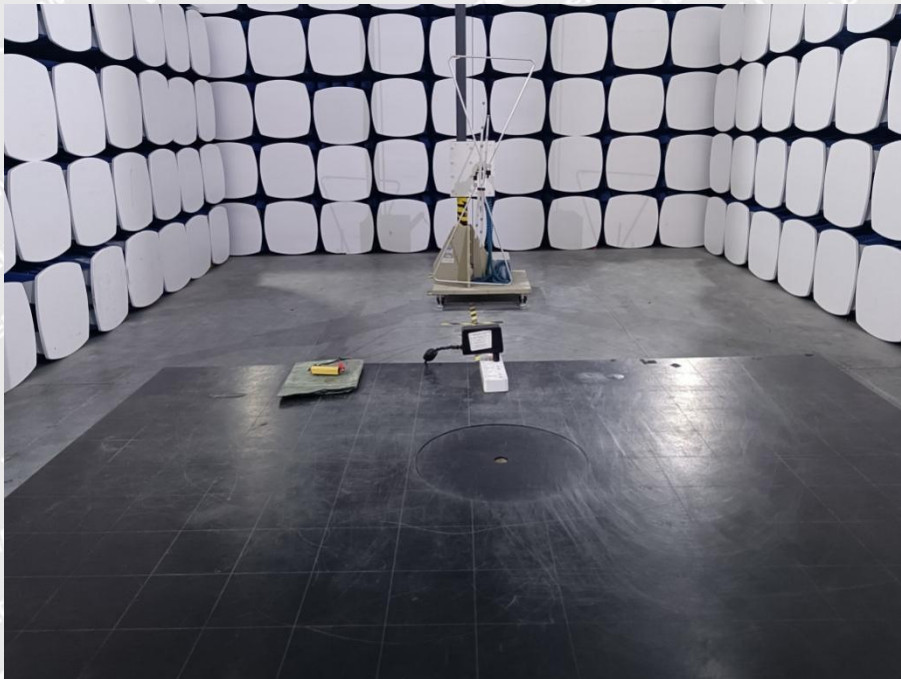



Reference No.: WTX22X07139237E

Harmonic/Flicker Test View



WALTEK

EN 61000-4-2 Test View

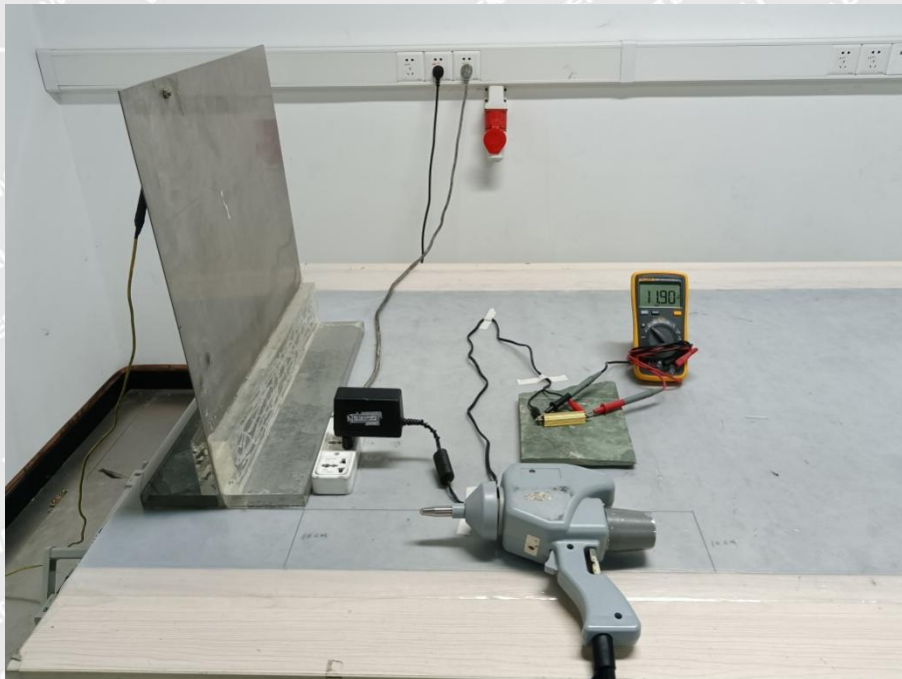



Reference No.: WTX22X07139237E

EN 61000-4-3 Test View

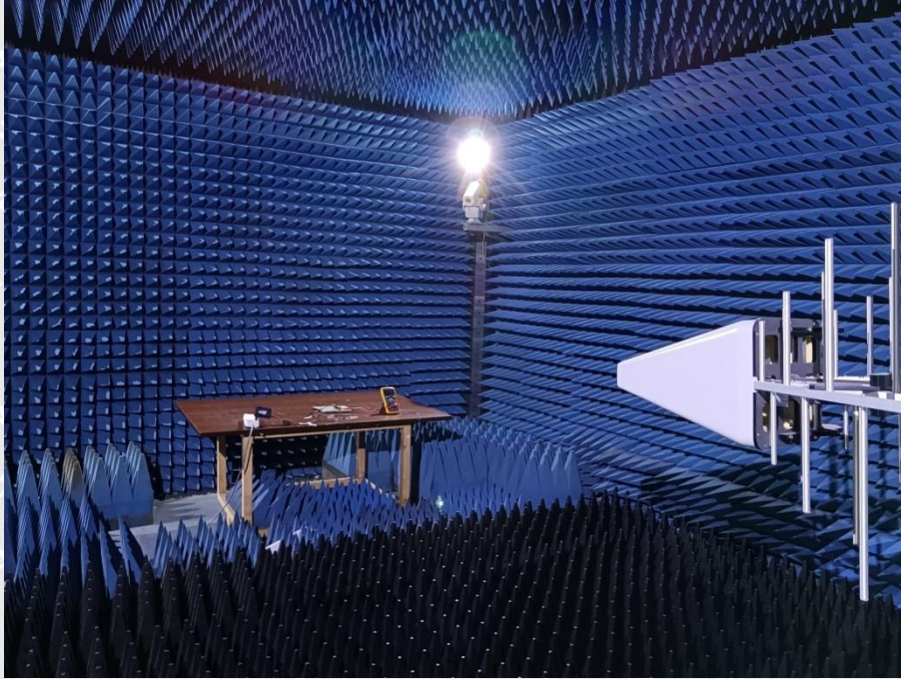

EN 61000-4-4/5/11 Test View

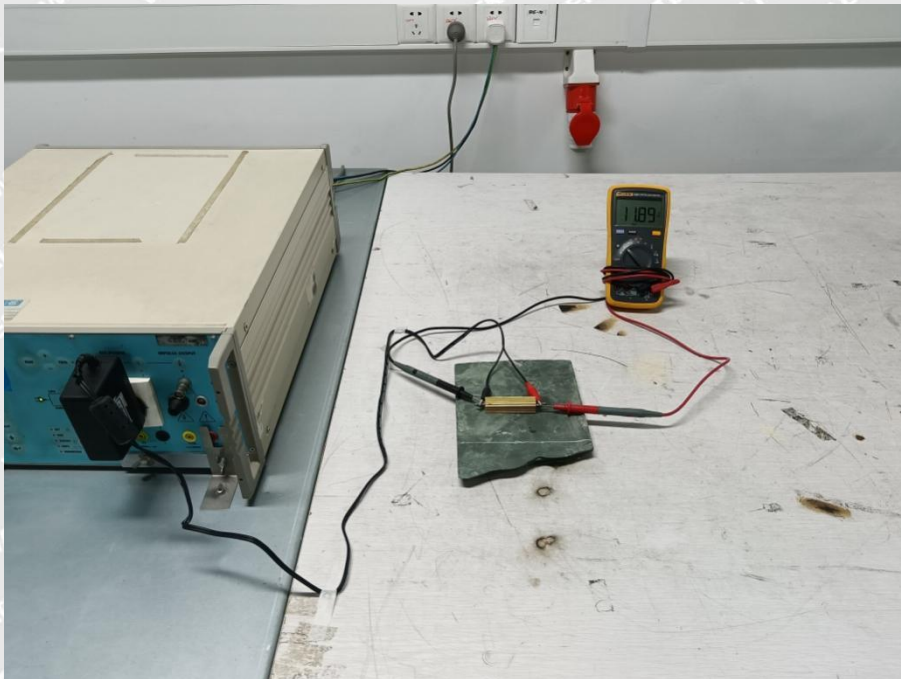



Reference No.: WTX22X07139237E

EN 61000-4-6 Test View

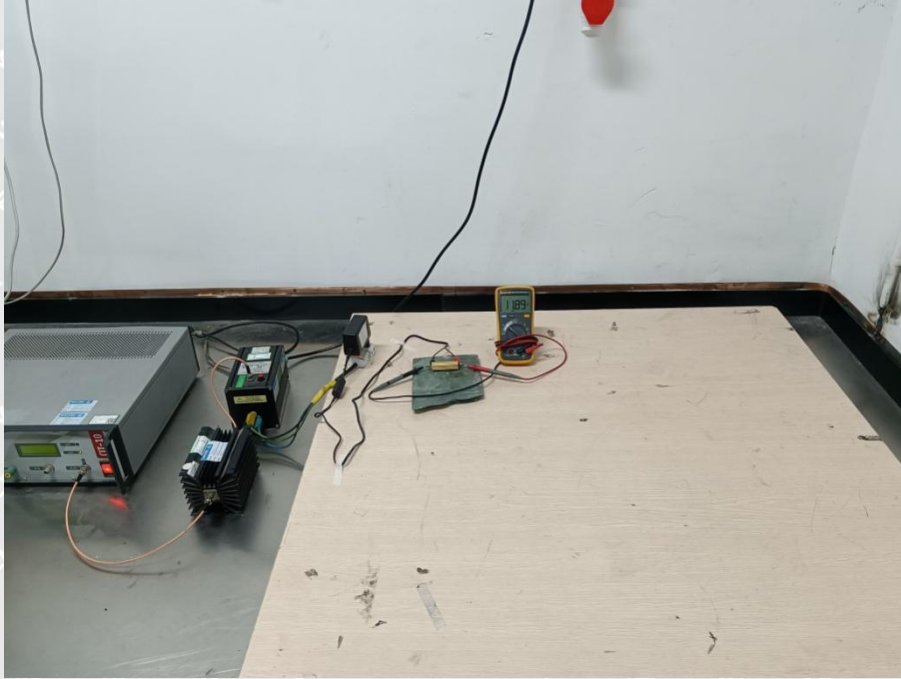

EN 61000-4-8 Test View

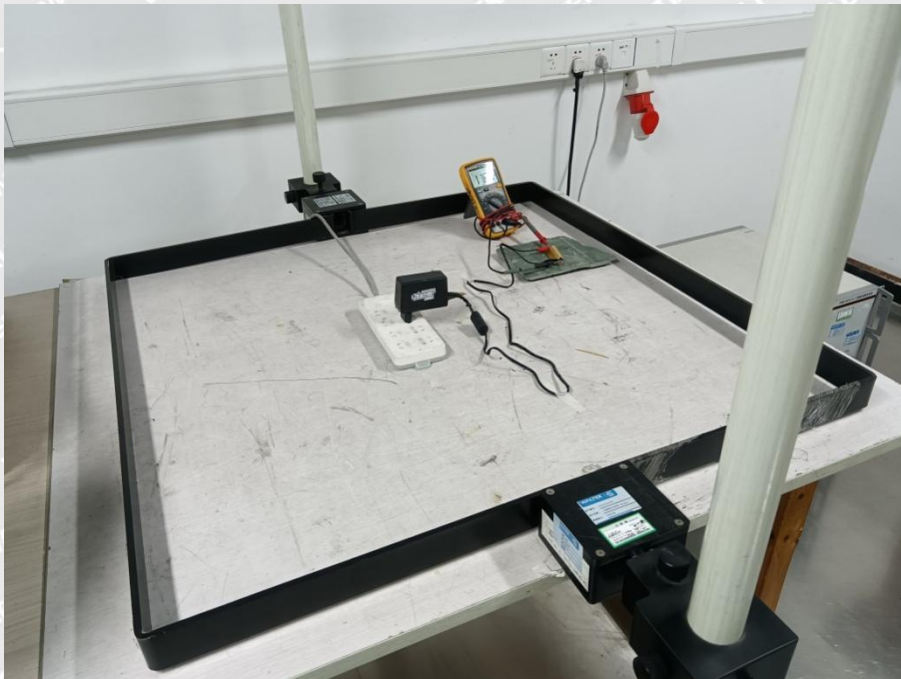

***** END OF REPORT *****