



<b>Prüfbericht - Nr.:</b> 50135052 001		Seite 1 von 24	
<i>Test Report No.:</i>		<i>Page 1 of 24</i>	
<b>Auftraggeber:</b> <i>Client:</i>	GlobTek, Inc. 186 Veterans Dr. Northvale, NJ 07647, USA		
<b>Gegenstand der Prüfung:</b> <i>Test item:</i>	Li-ion Battery		
<b>Bezeichnung:</b> <i>Identification:</i>	BL1200P4054481S1PC*C (*=A, B, C, H, J, K, L, M, N, P, Q, R, T, U, V, 1, 2, 3, 4, 5, 6, 7, 8, 9)	<b>Serien-Nr.:</b> <b>Serial No.:</b>	N/A
<b>Wareneingangs-Nr.:</b> <i>Receipt No.:</i>	164124204	<b>Eingangsdatum:</b> <i>Date of receipt:</i>	2018.05.25
<b>Prüfört:</b> <i>Testing location:</i>	Shenzhen LCS Compliance Testing Laboratory Ltd. 1/F, Xingyuan Industrial Park, Tongda Road, Bao'an Avenue, Bao'an District, Shenzhen, Guangdong, China		
<b>Prüfgrundlage:</b> <i>Test specification:</i>	UL 62133: 2015 +CAN/CSA-E62133:13		
<b>Prüfergebnis:</b> <i>Test Result:</i>	Der Prüfgegenstand entspricht oben genannter Prüfgrundlage(n). <i>The test item passed the test specification(s).</i>		
<b>Prüflaboratorium:</b> <i>Testing Laboratory:</i>	TÜV Rheinland (Shenzhen) Co., Ltd. 1F East & 2-4F, Cybio Technology Building No.1, No.16 Kejibei 2nd Road, High- Tech Industrial Park North Nanshan District, 518057, Shenzhen, China		
<b>geprüft/ tested by:</b>		<b>kontrolliert/ reviewed by:</b>	
 Jeffrey Qin		 Daniel Dai	
Jul 19, 2018	Jeffrey Qin / Project engineer	Jul 19, 2018	Daniel Dai/Reviewer
<i>Datum</i> <i>Date</i>	<i>Name/Stellung</i> <i>Name/Position</i>	<i>Datum</i> <i>Date</i>	<i>Name/Stellung</i> <i>Name/Position</i>
	<i>Unterschrift</i> <i>Signature</i>		<i>Unterschrift</i> <i>Signature</i>
<b>Sonstiges/ Other Aspects:</b>			
TUV Rheinland cTUVus approval procedure. The complete test report includes the following documents:			
- UL 62133 test report (24 pages);			
- Attachment 1: Equipment list (3 pages)			
- Attachment 2: Photo documents (4 pages).			
<b>Abkürzungen:</b>	P(ass) = entspricht Prüfgrundlage	<b>Abbreviations:</b>	P(ass) = passed
	F(ail) = entspricht nicht Prüfgrundlage		F(ail) = failed
	N/A = nicht anwendbar		N/A = not applicable
	N/T = nicht getestet		N/T = not tested
<p><b>Dieser Prüfbericht bezieht sich nur auf das o.g. Prüfmuster und darf ohne Genehmigung der Prüfstelle nicht auszugsweise vervielfältigt werden. Dieser Bericht berechtigt nicht zur Verwendung eines Prüfzeichens.</b></p> <p><i>This test report relates to the a. m. test sample. Without permission of the test center this test report is not permitted to be duplicated in extracts. This test report does not entitle to carry any safety mark on this or similar products.</i></p>			

<b>Test item description</b> ..... :	Li-ion Battery
<b>Trade Mark</b> ..... :	
<b>Manufacturer</b> .....	GlobTek, Inc.
<b>Address</b> ..... :	186 Veterans Dr. Northvale, NJ 07647, USA
<b>Model/Type reference</b> ..... :	BL1200P4054481S1PC*C (*=A, B, C, H, J, K, L, M, N, P, Q, R, T, U, V, 1, 2, 3, 4, 5, 6, 7, 8, 9)
<b>Ratings</b> ..... :	3.7V, 1100mAh, 4.07Wh

<b>Summary of testing:</b>	
<p><b>Tests performed (name of test and test clause):</b></p> <ul style="list-style-type: none"> <li>cl.5.6.2 Design recommendation(Lithium system);</li> <li>cl.8.1 Charging procedure for test purposes (for Cells and Batteries);</li> <li>cl.8.2.1 Continuous charging at constant voltage (Cells);</li> <li>cl. 8.2.2 Moulded case stress at high ambient temperature (Batteries);</li> <li>cl.8.3.1 External short circuit (Cells);</li> <li>cl.8.3.2 External short circuit (Batteries);</li> <li>cl.8.3.3 Free fall (for Cells and Batteries);</li> <li>cl.8.3.4 Thermal abuse (Cells);</li> <li>cl.8.3.5 Crush (Cells);</li> <li>cl.8.3.6 Over-charging of battery;</li> <li>cl.8.3.7 Forced discharge (Cells);</li> <li>cl.8.3.8 Transport tests (Cells).</li> </ul> <p>The applicant declares that this battery isn't to be sold in France, Japan, Republic of Korea and Switzerland.</p> <p>Tests are made with the number of cells and batteries specified in UL 62133: 2015 Table 2.</p>	<p><b>Testing location:</b></p> <p><b>Shenzhen LCS Compliance Testing Laboratory Ltd.</b></p> <p>1/F, Xingyuan Industrial Park, Tongda Road, Bao'an Avenue, Bao'an District, Shenzhen, Guangdong, China</p>

**Copy of marking plate:**

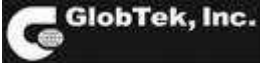
The artwork below may be only a draft. The use of certification marks on a product must be authorized by the respective NCBs that own these marks.

**GlobTek, Inc.**  
www.globtek.com

1ICP4/45/47 Li-ion Battery

**BL1200P4054481S1PCKC**

**Li-ion 3.7V 1100mAh 4.07Wh**

**CAUTION:**

- May explode if disposed of in fire.
- Use specified charger only.
- Do not short circuit.

**Avertissement:**

- Peut exploser si jetés dans le feu. <sup>c</sup>
- Utilisez uniquement le chargeur spécifié.
- Ne fais pas le court-circuit.

**MADE IN CHINA** **201802**

**Remark:**

BL1200P4054481S1PC\*C (\*=A, B, C, H, J, K, L, M, N, P, Q, R, T, U, V, 1, 2, 3, 4, 5, 6, 7, 8, 9) for market purpose only, all models are identical except the model name.

<b>Test item particulars</b> .....:	
<b>Classification of installation and use</b> .....:	To be defined in final product
<b>Supply connection</b> .....:	DC connector
<b>Recommend charging method declared by the manufacturer</b> .....	Charging the battery with 220mA constant current until 4.2V and then constant voltage until charging current reduces to 11mA at ambient 20°C±5°C.
<b>Discharge current (0,2 I<sub>t</sub> A)</b> .....	220mA
<b>Specified final voltage</b> .....	3.0V
<b>Chemistry</b> .....	<input type="checkbox"/> nickel systems ..... <input checked="" type="checkbox"/> lithium systems
<b>Recommend of charging limit for lithium system</b>	
<b>Upper limit charging voltage per cell</b> .....:	4.25V
<b>Maximum charging current</b> .....	1100mA
<b>Charging temperature upper limit</b> .....	45°C
<b>Charging temperature lower limit</b> .....:	0°C
<b>Polymer cell electrolyte type</b> .....	<input type="checkbox"/> gel polymer <input type="checkbox"/> solid polymer <input checked="" type="checkbox"/> N/A
<b>Possible test case verdicts:</b>	
- test case does not apply to the test object.....:	N/A
- test object does meet the requirement.....:	P (Pass)
- test object does not meet the requirement.....:	F (Fail)
<b>Testing</b> .....:	
<b>Date of receipt of test item</b> .....	2018-06-05
<b>Date (s) of performance of tests</b> .....	2018-06-05 to 2018-06-25
<b>General remarks:</b>	
The test results presented in this report relate only to the object tested. This report shall not be reproduced, except in full, without the written approval of the Issuing testing laboratory. "(See Enclosure #)" refers to additional information appended to the report. "(See appended table)" refers to a table appended to the report. <b>Throughout this report a <input type="checkbox"/> comma / <input checked="" type="checkbox"/> point is used as the decimal separator.</b>	
<b>Name and address of factory (ies)</b>	

**General product information:**

This battery is constructed with one lithium-ion cell (1S1P), and has overcharge, over-discharge, over current and short-circuits proof circuit.

All models are identical except the model name, Definition of variable for the model BL1200P4054481S1PC\*C, the "\*" means the connector type, see below table for details:

Variable	Range of variable	Content
*	A, B, C, H, J, K, L, M, N, P, Q, R, T, U, V, 1, 2, 3, 4, 5, 6, 7, 8, 9	A = Strip + tin, B = Button, C = Contacts, H=Hirose(any style), J = 2p JST, K =3pJST, L = 4p JST, M = 2p Molex, N = 3p Molex, P = 4p Molex, Q = 6 contacts Molex, R = Multiple connectors, T= 2p Tyco, U= 3p Tyco, V = 4p Tyco, 1 = 1p connector, 2 =2p connector, 3= 3p connector, 4 = 4p connector, 5 =5p connector, 6 = 6pconnector, 7 = 7p connector, 8 =8p connector, 9 = 9p connector.

The main features of the battery pack are shown as below (clause 8.1.1):

Model	Nominal capacity	Nominal voltage	Nominal Charge Current	Nominal Discharge Current	Maximum Charge Current	Maximum Discharge Current	Maximum Charge Voltage	Cut-off Voltage
BL1200P4054481S1PC*C (*=A, B, C, H, J, K, L, M, N, P, Q, R, T, U, V, 1, 2, 3, 4, 5, 6, 7, 8, 9)	1100mAh	3.7V	220mA	220mA	1100mA	1100mA	4.2V	3.0V

The main features of the battery pack are shown as below (clause 8.1.2):

Model	Upper limit charge voltage	Taper-off current	Lower charge temperature	Upper charge temperature
BL1200P4054481S1PC*C (*=A, B, C, H, J, K, L, M, N, P, Q, R, T, U, V, 1, 2, 3, 4, 5, 6, 7, 8, 9)	4.25V	55mA	0°C	45°C

The main features of the cell in the battery pack are shown as below (clause 8.1.1):

Model	Nominal capacity	Nominal voltage	Nominal Charge Current	Nominal Discharge Current	Maximum Charge Current	Maximum Discharge Current	Maximum Charge Voltage	Cut-off Voltage
GP404852	1100mAh	3.7V	220mA	220mA	1100mA	1100mA	4.2V	3.0V

The main features of the cell in the battery pack are shown as below (clause 8.1.2):

Model	Upper limit charge voltage	Taper-off current	Lower charge temperature	Upper charge temperature
GP404852	4.25V	55mA	0C	45°C

Construction:

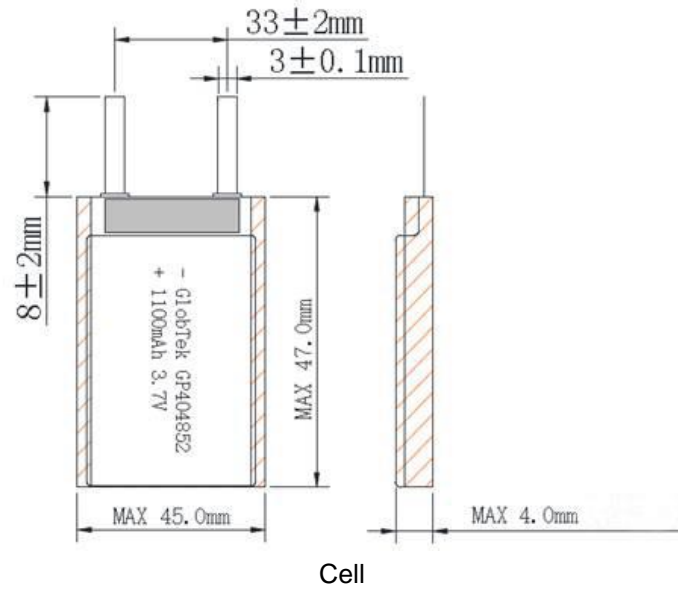

Cell

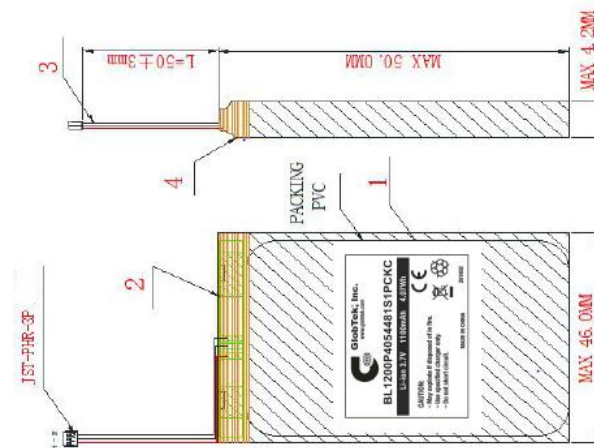

Battery

Circuit diagram:

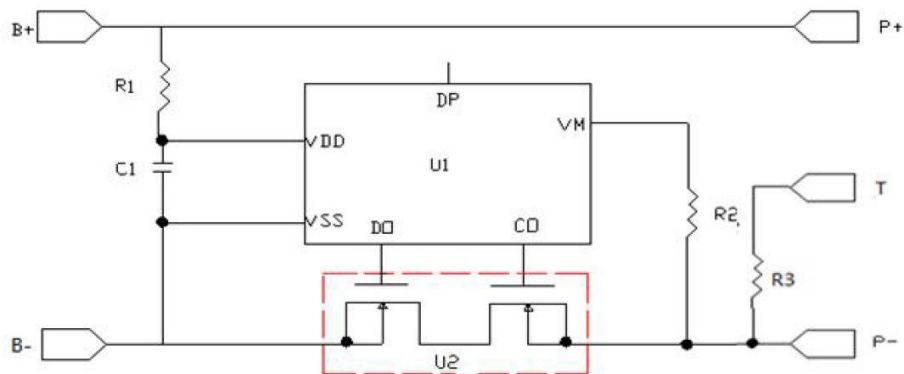

<b>UL 62133: 2015 +CAN/CSA-E62133:13</b>			
<b>Clause</b>	<b>Requirement + Test</b>	<b>Result - Remark</b>	<b>Verdict</b>
<b>4</b>	<b>Parameter measurement tolerances</b>		<b>P</b>
	Parameter measurement tolerances		P
<b>5</b>	<b>General safety considerations</b>		<b>P</b>
5.1	General		P
5.2	Insulation and wiring		P
	The insulation resistance between the positive terminal and externally exposed metal surfaces of the battery (excluding electrical contact surfaces) is not less than 5 MΩ	No metal case exists.	N/A
	Insulation resistance (MΩ)..... :		—
	Internal wiring and insulation are sufficient to withstand maximum anticipated current, voltage and temperature requirements		P
	Orientation of wiring maintains adequate creepage and clearance distances between conductors		P
	Mechanical integrity of internal connections accommodates reasonably foreseeable misuse		P
5.3	Venting		P
	Battery cases and cells incorporate a pressure relief mechanism or are constructed so that they relieve excessive internal pressure at a value and rate that will preclude rupture, explosion and self-ignition	Venting mechanism exists on the narrow side of the cell.	P
	Encapsulation used to support cells within an outer casing does not cause the battery to overheat during normal operation nor inhibit pressure relief		N/A
5.4	Temperature/voltage/current management		P
	Batteries are designed such that abnormal temperature rise conditions are prevented	Overcharge, overdischarge, over current and short-circuit proof circuit used in this battery. See tests of clause 8.	P
	Batteries are designed to be within temperature, voltage and current limits specified by the cell manufacturer	See above.	P
	Batteries are provided with specifications and charging instructions for equipment manufacturers so that associated chargers are designed to maintain charging within the temperature, voltage and current limits specified	The charging limits specified in the manufacturer's specifications.	P
5.5	Terminal contacts		P
	Terminals have a clear polarity marking on the external surface of the battery	DC connector used.	P



UL 62133: 2015 +CAN/CSA-E62133:13			
Clause	Requirement + Test	Result - Remark	Verdict
	The size and shape of the terminal contacts ensure that they can carry the maximum anticipated current	DC connector contacts complied with the requirements.	P
	External terminal contact surfaces are formed from conductive materials with good mechanical strength and corrosion resistance	Complied.	P
	Terminal contacts are arranged to minimize the risk of short circuits	Complied.	P
5.6	Assembly of cells into batteries		P
5.6.1	If there is more than one battery housed in a single battery case, cells used in the assembly of each battery have closely matched capacities, be of the same design, be of the same chemistry and be from the same manufacturer	Single cell battery	N/A
	Each battery has an independent control and protection		N/A
	Manufacturers of cells make recommendations about current, voltage and temperature limits so that the battery manufacturer/designer may ensure proper design and assembly		N/A
	Batteries that are designed for the selective discharge of a portion of their series connected cells incorporate separate circuitry to prevent the cell reversal caused by uneven discharges		N/A
	Protective circuit components are added as appropriate and consideration given to the end-device application		N/A
	When testing a battery, the manufacturer of the battery provides a test report confirming the compliance according to this standard		N/A
5.6.2	Design recommendation for lithium systems only		P
	For the battery consisting of a single cell or a single cellblock: - Charging voltage of the cell does not exceed the upper limit of the charging voltage specified in Clause 8.1.2, Table 4; or	Charging voltage: 4.2V, not exceed 4.25V specified in Clause 8.1.2, Table 4.	P
	- Charging voltage of the cell does not exceed the different upper limit of the charging voltage determined through Clause 8.1.2, NOTE 1.		N/A
	For the battery consisting of series-connected plural single cells or series-connected plural cellblocks: - The voltages of any one of the single cells or single cellblocks does not exceed the upper limit of the charging voltage, specified in Clause 8.1.2, Table 4, by monitoring the voltage of every single cell or the single cellblocks; or		N/A



<b>UL 62133: 2015 +CAN/CSA-E62133:13</b>			
<b>Clause</b>	<b>Requirement + Test</b>	<b>Result - Remark</b>	<b>Verdict</b>
	- The voltages of any one of the single cells or single cellblocks does not exceed the different upper limit of the charging voltage, determined through Clause 8.1.2, NOTE 1, by monitoring the voltage of every single cell or the single cellblocks		N/A
	For the battery consisting of series-connected plural single cells or series-connected plural cellblocks: - Charging is stopped when the upper limit of the charging voltage, specified in Clause 8.1.2, Table 4, is exceeded for any one of the single cells or single cellblocks by measuring the voltage of every single cell or the single cellblocks; or		N/A
	- Charging is stopped when the upper limit of the different charging voltage, determined through Clause 8.1.2, NOTE 1, is exceeded for any one of the single cells or single cellblocks by measuring the voltage of every single cell or the single cellblocks		N/A
5.7	Quality plan		P
	The manufacturer prepares and implements a quality plan that defines procedures for the inspection of materials, components, cells and batteries and which covers the whole process of producing each type of cell or battery	Complied. ISO 9001: 2008 certificate provided.	P
<b>6</b>	<b>Type test conditions</b>		<b>P</b>
	Tests were made with the number of cells or batteries specified in Table 1 for nickel-cadmium and nickel-metal hydride systems and Table 2 for lithium systems, using cells or batteries that are not more than six months old	Complied. Lithium system.	P
	Unless noted otherwise in the test methods, testing was conducted in an ambient of 20°C ± 5°C.	Tests are carried out at 20°C ± 5°C.	P
<b>7</b>	<b>Specific requirements and tests (nickel systems)</b>		<b>N/A</b>
7.1	Charging procedure for test purposes	Lithium system.	N/A
7.2	Intended use		N/A
7.2.1	Continuous low-rate charging (cells)		N/A
	Results: No fire. No explosion		N/A
7.2.2	Vibration		N/A
	Results: No fire. No explosion. No leakage		N/A
7.2.3	Moulded case stress at high ambient temperature		N/A
	Oven temperature (°C) .....		—
	Results: No physical distortion of the battery casing resulting in exposure if internal components		N/A
7.2.4	Temperature cycling		N/A

UL 62133: 2015 +CAN/CSA-E62133:13			
Clause	Requirement + Test	Result - Remark	Verdict
	Results: No fire. No explosion. No leakage.		N/A
7.3	Reasonably foreseeable misuse		N/A
7.3.1	Incorrect installation cell		N/A
	The test was carried out using: - Four fully charged cells of the same brand, type, size and age connected in series, with one of them reversed; or		N/A
	- A stabilized dc power supply.		N/A
	Results: No fire. No explosion .....		N/A
7.3.2	External short circuit		N/A
	The cells or batteries were tested until one of the following occurred: - 24 hours elapsed; or		N/A
	- The case temperature declined by 20% of the maximum temperature rise		N/A
	Results: No fire. No explosion .....		N/A
7.3.3	Free fall		N/A
	Results: No fire. No explosion.		N/A
7.3.4	Mechanical shock (crash hazard)		N/A
	Results: No fire. No explosion. No leakage.		N/A
7.3.5	Thermal abuse		N/A
	Oven temperature (°C) .....		—
	Results: No fire. No explosion.		N/A
7.3.6	Crushing of cells		N/A
	The crushing force was released upon: - The maximum force of 13 kN ± 1 kN has been applied; or		N/A
	- An abrupt voltage drop of one-third of the original voltage has been obtained		N/A
	The cell is prismatic type and a second set of samples was tested, rotated 90° around longitudinal axis compared to the first set		N/A
	Results: No fire. No explosion .....		N/A
7.3.7	Low pressure		N/A
	Chamber pressure (kPa) .....		—
	Results: No fire. No explosion. No leakage.		N/A
7.3.8	Overcharge		N/A
	Results: No fire. No explosion .....		N/A
7.3.9	Forced discharge		N/A

UL 62133: 2015 +CAN/CSA-E62133:13			
Clause	Requirement + Test	Result - Remark	Verdict
	Results: No fire. No explosion .....		N/A
<b>8</b>	<b>Specific requirements and tests (lithium systems)</b>		<b>P</b>
8.1	Charging procedures for test purposes	Complied.	P
8.1.1	First procedure: This charging procedure applied to tests other than those specified in 8.1.2		P
8.1.2	Second procedure: This charging procedure applied to the tests of 8.3.1, 8.3.2, 8.3.4, 8.3.5, and 8.3.9		P
	If a cell's specified upper and/or lower charging temperature exceeds values for the upper and/or lower limit test temperatures of Table 4, the cells were charged at the specified values plus 5 °C for the upper limit and minus 5 °C for the lower limit	Charge temperature 0-45°C declared. 45°C used for upper limit tests; -5°C used for lower limit tests.	P
	A valid rationale was provided to ensure the safety of the cell (see Figure A.1) .....		P
	For a different upper limit charging voltage (i.e. other than for lithium cobalt oxide systems at 4,25 V), the applied upper limit charging voltage and upper limit charging temperatures were adjusted accordingly	Lithium cobalt oxide system only.	N/A
	A valid rationale was provided to ensure the safety of the cell (see Figure A.1) .....		N/A
8.2	Intended use		P
8.2.1	Continuous charging at constant voltage (cells)	Tested complied.	P
	Results: No fire. No explosion .....	(See Table 8.2.1)	P
8.2.2	Moulded case stress at high ambient temperature (battery)	Tested as client request	P
	Oven temperature (°C) .....	70°C	—
	Results: No physical distortion of the battery casing resulting in exposure of internal components	No physical distortion of the battery casing resulting in exposure of internal components.	P
8.3	Reasonably foreseeable misuse		P
8.3.1	External short circuit (cell)	Tested complied.	P
	The cells were tested until one of the following occurred: - 24 hours elapsed; or		N/A
	- The case temperature declined by 20% of the maximum temperature rise		P
	Results: No fire. No explosion .....	(See Table 8.3.1)	P
8.3.2	External short circuit (battery)	Tested complied.	P

UL 62133: 2015 +CAN/CSA-E62133:13			
Clause	Requirement + Test	Result - Remark	Verdict
	The batteries were tested until one of the following occurred: - 24 hours elapsed; or		P
	- The case temperature declined by 20% of the maximum temperature rise		N/A
	In case of rapid decline in short circuit current, the battery pack remained on test for an additional one hour after the current reached a low end steady state condition		N/A
	Results: No fire. No explosion .....	(See Table 8.3.2)	P
8.3.3	Free fall	Tested complied.	P
	Results: No fire. No explosion.	No fire. No explosion.	P
8.3.4	Thermal abuse (cells)	Tested complied.	P
	The cells were held at 130°C ± 2°C for: - 10 minutes; or		P
	- 30 minutes for large cells (gross mass of more than 500 g as defined in IEC 62281)		N/A
	Oven temperature (°C) .....	130°C	—
	Gross mass of cell (g) .....	<500g, small cell.	—
	Results: No fire. No explosion.	No fire. No explosion.	P
8.3.5	Crush (cells)	Tested complied.	P
	The crushing force was released upon: - The maximum force of 13 kN ± 1 kN has been applied; or		P
	- An abrupt voltage drop of one-third of the original voltage has been obtained; or		N/A
	- 10% of deformation has occurred compared to the initial dimension		N/A
	Results: No fire. No explosion .....	(See Table 8.3.5)	P
8.3.6	Over-charging of battery	Tested complied.	P
	Test was continued until the temperature of the outer casing: - Reached steady state conditions (less than 10°C change in 30-minute period); or		N/A
	- Returned to ambient		P
	Results: No fire. No explosion .....	(See Table 8.3.6)	P
8.3.7	Forced discharge (cells)	Tested complied.	P
	Results: No fire. No explosion .....	(See Table 8.3.7)	P
8.3.8	Transport tests	Tested complied.	P

UL 62133: 2015 +CAN/CSA-E62133:13			
Clause	Requirement + Test	Result - Remark	Verdict
	Manufacturer's documentation provided to show compliance with UN Recommendations on Transport of Dangerous Goods		P
8.3.9	Design evaluation – Forced internal short circuit (cells)	Tested complied.	N/A
	The cells complied with national requirement for .....:	Not requested by client, not comply with the requirements of France, Japan, Republic of Korea and Switzerland.	—
	The pressing was stopped upon: - A voltage drop of 50 mV has been detected; or		N/A
	- The pressing force of 800 N (cylindrical cells) or 400 N (prismatic cells) has been reached		N/A
	Results: No fire .....		N/A
<b>9</b>	<b>Information for safety</b>		<b>P</b>
	The manufacturer of secondary cells ensures that information is provided about current, voltage and temperature limits of their products.	Information for safety mentioned in manufacturer's specifications.	P
	The manufacturer of batteries ensures that equipment manufacturers and, in the case of direct sales, end-users are provided with information to minimize and mitigate hazards.	Information for safety mentioned in manufacturer's specifications.	P
	Systems analyses performed by device manufacturers to ensure that a particular battery design prevents hazards from occurring during use of a product		N/A
	As appropriate, information relating to hazard avoidance resulting from a system analysis is provided to the end user .....		N/A
<b>10</b>	<b>Marking</b>		<b>P</b>
10.1	Cell marking		N/A
	Cells marked as specified in the applicable cell standards: IEC 61951-1, IEC 61951-2 or IEC 61960.	The final product is battery.	N/A
10.2	Battery marking		P
	Batteries marked in accordance with the requirements for the cells from which they are assembled.	The battery is marked in accordance with IEC 61960, also see page 4.	P
	Batteries marked with an appropriate caution statement.		P
10.3	Other information		P
	Storage and disposal instructions marked on or supplied with the battery.	Information for disposal instructions mentioned in manufacturer's specifications.	P

UL 62133: 2015 +CAN/CSA-E62133:13			
Clause	Requirement + Test	Result - Remark	Verdict
	Recommended charging instructions marked on or supplied with the battery.	Information for recommended charging instructions mentioned in manufacturer's specifications.	P
<b>11</b>	<b>Packaging</b>		<b>P</b>
	The materials and packaging design are chosen so as to prevent the development of unintentional electrical conduction, corrosion of the terminals and ingress of environmental contaminants.		P
<b>Annex A</b>	<b>Charging range of secondary lithium ion cells for safe use</b>		<b>P</b>
A.1	General		P
A.2	Safety of lithium-ion secondary battery	Complied.	P
A.3	Consideration on charging voltage	Complied.	P
A.3.1	General		P
A.3.2	Upper limit charging voltage	4.2V	P
A.3.2.1	General		P
A.3.2.2	Explanation of safety viewpoint		N/A
A.3.2.3	Safety requirements, when different upper limit charging voltage is applied	4.25V applied.	N/A
A.4	Consideration of temperature and charging current		P
A.4.1	General		P
A.4.2	Recommended temperature range	See A.4.2.2.	P
A.4.2.1	General		P
A.4.2.2	Safety consideration when a different recommended temperature range is applied	Charging temperature range declared by client is: 0-45°C	P
A.4.3	High temperature range	Not higher than the temperature specific in this standard.	N/A
A.4.3.1	General		N/A
A.4.3.2	Explanation of safety viewpoint		N/A
A.4.3.3	Safety considerations when specifying charging conditions in high temperature range		N/A
A.4.3.4	Safety consideration when specifying new upper limit in high temperature range		N/A
A.4.4	Low temperature range	Charging low temperature declared by client is 0°C.	P
A.4.4.1	General		P
A.4.4.2	Explanation of safety viewpoint		P

UL 62133: 2015 +CAN/CSA-E62133:13			
Clause	Requirement + Test	Result - Remark	Verdict
A.4.4.3	Safety considerations, when specifying charging conditions in low temperature range		P
A.4.4.4	Safety considerations when specifying a new lower limit in the low temperature range	-5°C applied	P
A.4.5	Scope of the application of charging current		P
A.5	Sample preparation		N/A
A.5.1	General		N/A
A.5.2	Insertion procedure for nickel particle to generate internal short		N/A
	The insertion procedure carried out at 20°C±5°C and under -25 °C of dew point		N/A
A.5.3	Disassembly of charged cell		N/A
A.5.4	Shape of nickel particle		N/A
A.5.5	Insertion of nickel particle to cylindrical cell		N/A
A.5.5.1	Insertion of nickel particle to winding core		N/A
A.5.5.2	Mark the position of nickel particle on the both end of winding core of the separator		N/A
A.5.6	Insertion of nickel particle to prismatic cell		N/A



TABLE: Critical components information					P
Object/part no.	Manufacturer/trademark	Type/model	Technical data	Standard	Mark(s) of conformity <sup>1)</sup>
Cell		GP404852	3.7V, 1100mAh	UL 62133: 2015 +CAN/CSA-E62133:13	Tested with appliance
-Positive Electrode	Hunan Shanshan Technology Co., Ltd	LC420	LiCoO <sub>2</sub> , Carbon black, PVdF, Conductive Additive: Aluminum foil D50=14.00±2.00µm	--	--
-Negative Electrode	TIG ELECTRONIC TECHNOLOGIES CO., LTD	G1	Graphite, CMC, SBR, Conductive Additive: Copper foil D50=20.0±2.0µm	--	--
-Positive electrode tab	Foshan zhongji Co., Ltd	Al	0.012mm*450mm	--	--
-Negative electrode tab	Tongling huilifeng Co., Ltd	Ni	0.008mm*490mm	--	--
-Separator	Shenzhen Senior Technology Material Co., LTD	STW1242	0.012*42mm-PE Shutdown temperature:130-135 C	--	--
-Electrolyte	Suzhou Dingcheng New Energy Technology Co., Ltd	DC-HL001	Conductivity:7.9±0.5 mS/cm, LiPF <sub>6</sub> , C <sub>3</sub> H <sub>4</sub> O <sub>3</sub> , C <sub>4</sub> H <sub>6</sub> O <sub>3</sub> , C <sub>3</sub> H <sub>10</sub> O <sub>3</sub> , etc.	--	--
-Aluminium plastic film	TIG ELECTRONIC TECHNOLOGIES CO., LTD	0.113*100mm	0.113*100mm*93.5mm	--	--
MOSFET (U2)	Developer microelectronics	DP8205-TSSOP-8	V <sub>DS</sub> :20V, V <sub>GS</sub> :±12V, I <sub>D</sub> :6A, T <sub>stg</sub> : -55-150 C	--	Tested with appliance
IC (U1)	SEIKO	S-8261ABJMD-G3JT2G	V <sub>CU</sub> =4.28 ± 0.025V, V <sub>DL</sub> =3.0± 0.05V, T <sub>opr</sub> =-40-85°C	--	Tested with appliance
PCB	KINGBOARD LAMINATES HOLDINGS LTD	KB-5150	V-0, 130 C	UL 796 CAN/CSA-C22.2 No. 0.17	UL E123995
PCB	Interchangeable	Interchangeable	V-0, 130 C	UL 796 CAN/CSA-C22.2 No. 0.17	UL approved
Lead wire	DONGGUAN WENCHANG ELECTRONIC CO LTD	1571	Min. 28AWG, VW-1, 80 C, 30V	UL 758 CSA-C22.2 No. 127.	UL E214500
Lead wire	Interchangeable	Interchangeable	Min. 28AWG, VW-1, 80 C, 30V	UL 758 CSA-C22.2 No. 127.	UL approved
Connector	JAPAN SOLDERLESS TERMINAL MFG CO LTD	JST-PHR	V-0, 130 C, I <sub>max</sub> =2A	UL 94 CSA-C22.2 No. 182.3	UL E60389

Connector	Interchangeable	Interchangeable	V-0, 130°C, I <sub>max</sub> =2A	UL 94 CSA-C22.2 No. 182.3	UL approved
<b>Supplementary information:</b> 1) Provided evidence ensures the agreed level of compliance.					

7.2.1	TABLE: Continuous low rate charge (cells)					N/A
Model	Recommended charging method, (CC, CV, or CC/CV)	Recommended charging voltage $V_c$ , (Vdc)	Recommended charging current $I_{rec}$ , (A)	OCV at start of test, (Vdc)	Results	

**Supplementary information:**

- No fire or explosion
- No leakage
- Leakage
- Fire
- Explosion
- Bulge
- Others (please explain)

7.2.2	TABLE: Vibration		N/A
Model	OCV at start of test, (Vdc)	Results	

**Supplementary information:**

- No fire or explosion
- No leakage
- Leakage
- Fire
- Explosion
- Bulge
- Others (please explain)

7.3.1	TABLE: Incorrect installation (cells)		N/A
Model	OCV of reversed cell, (Vdc)	Results	

**Supplementary information:**

- No fire or explosion
- No leakage
- Leakage
- Fire
- Explosion
- Bulge
- Others (please explain)

7.3.2	TABLE: External short circuit					N/A
Model	Ambient (at 20°C ± 5°C or 55°C ± 5°C)	OCV at start of test, (Vdc)	Resistance of circuit, (Ω)	Maximum case temperature rise ΔT, (°C)	Results	

**Supplementary information:**

- No fire or explosion
- No leakage
- Leakage
- Fire
- Explosion
- Bulge
- Others (please explain)

7.3.6	TABLE: Crush			N/A
Model	OCV at start of test, (Vdc)	OCV at removal of crushing force, (Vdc)	Results	

**Supplementary information:**

- No fire or explosion
- No leakage
- Leakage
- Fire
- Explosion
- Bulge
- Others (please explain)

7.3.8	TABLE: Overcharge				N/A
Model	OCV prior to charging, (Vdc)	Maximum charge current, (A)	Time for charging, (hours)	Results	

**Supplementary information:**

- No fire or explosion
- No leakage
- Leakage
- Fire
- Explosion
- Bulge
- Others (please explain)

7.3.9	TABLE: Forced discharge (cells)				N/A
Model	OCV before application of reverse charge, (Vdc)	Measured reverse charge $I_t$ , (mA)	Time for reversed charge, (minutes)	Results	

**Supplementary information:**

- No fire or explosion
- No leakage
- Leakage
- Fire
- Explosion
- Bulge
- Others (please explain)

8.2.1	TABLE: Continuous charging at constant voltage (cells)				P
Model	Recommended charging voltage $V_C$ , (Vdc)	Recommended charging current $I_{rec}$ , (mA)	OCV at start of test, (Vdc)	Results	
Cell #1	4.20	220	4.20	P	
Cell #2	4.20	220	4.20	P	
Cell #3	4.20	220	4.20	P	
Cell #4	4.20	220	4.20	P	
Cell #5	4.20	220	4.20	P	
<b>Supplementary information:</b>					
<ul style="list-style-type: none"> <li>- No fire</li> <li>- No explosion</li> <li>- No leakage</li> </ul>					

8.3.1	TABLE: External short circuit (cells)					P
Model	Ambient, (°C)	OCV at start of test, (Vdc)	Resistance of circuit, (mΩ)	Maximum case temperature rise $\Delta T$ , (°C)	Results	
<b>Samples charged at charging temperature upper limit (45°C)</b>						
Cell #1	24.3	4.21	82	107.7	P	
Cell #2	24.3	4.21	81	111.4	P	
Cell #3	24.3	4.21	84	109.2	P	
Cell #4	24.3	4.22	83	103.4	P	
Cell #5	24.3	4.21	82	116.3	P	
<b>Samples charged at charging temperature lower limit (-5°C)</b>						
Cell #6	24.4	4.15	82	110.3	P	
Cell #7	24.4	4.15	83	109.1	P	
Cell #8	24.4	4.15	83	108.5	P	
Cell #9	24.4	4.15	84	114.6	P	
Cell #10	24.4	4.14	81	119.2	P	
<b>Supplementary information:</b>						
<ul style="list-style-type: none"> <li>- No fire</li> <li>- No explosion</li> </ul>						

8.3.2	TABLE: External short circuit (battery)					P
Model	Ambient, (°C)	OCV at start of test, (Vdc)	Resistance of circuit, (mΩ)	Maximum case temperature rise $\Delta T$ , (°C)	Results	
<b>Samples charged at charging temperature upper limit (45°C)</b>						
B1#	55.6	4.21	82	55.9	P	
B2#	55.6	4.21	83	56.3	P	
B3#	55.6	4.21	81	55.8	P	
B4#	55.6	4.22	84	56.1	P	
B5#	55.6	4.22	83	56.2	P	
<b>Samples charged at charging temperature lower limit (-5°C)</b>						
B6#	55.5	4.14	82	55.8	P	
B7#	55.5	4.15	83	56.3	P	
B8#	55.5	4.15	84	56.1	P	
B9#	55.5	4.15	82	56.2	P	
B10#	55.5	4.14	81	55.9	P	
<b>Supplementary information:</b>						
- No fire						
- No explosion						

8.3.5	TABLE: Crush					P
Model	OCV at start of test, (Vdc)	OCV at removal of crushing force, (Vdc)	Width/diameter of cell before crush, (mm)	Required deformation for crush, (mm)	Results	
<b>Samples charged at charging temperature upper limit (45°C)</b>						
Cell #1	4.21	4.21	--	--	P	
Cell #2	4.20	4.20	--	--	P	
Cell #3	4.20	4.20	--	--	P	
Cell #4	4.21	4.20	--	--	P	
Cell #5	4.21	4.21	--	--	P	
<b>Samples charged at charging temperature upper limit (-5°C)</b>						
Cell #6	4.15	4.15	--	--	P	
Cell #7	4.14	4.14	--	--	P	
Cell #8	4.15	4.15	--	--	P	
Cell #9	4.15	4.14	--	--	P	
Cell #10	4.14	4.14	--	--	P	



**Note:**  
**A 13kN force applied at the wide side of prismatic cells.**  
**Supplementary information:**  
 - No fire  
 - No explosion

8.3.6	TABLE: Over-charging of battery				P
Constant charging current (A).....:		2.2		—	
Supply voltage (Vdc).....:		5		—	
Model	OCV before charging, (Vdc)	Resistance of circuit, (mΩ)	Maximum outer casing temperature, (°C)	Results	
B1#	3.28	--	35.8	P	
B2#	3.29	--	36.9	P	
B3#	3.28	--	37.3	P	
B4#	3.27	--	38.9	P	
B5#	3.28	--	38.8	P	
<b>Supplementary information:</b> - No fire - No explosion					

8.3.7	TABLE: Forced discharge (cells)				P
Model	OCV before application of reverse charge, (Vdc)	Measured Reverse charge I <sub>r</sub> , (mA)	Time for reversed charge, (minutes)	Results	
Cell #1	3.27	1100	90	P	
Cell #2	3.28	1100	90	P	
Cell #3	3.29	1100	90	P	
Cell #4	3.27	1100	90	P	
Cell #5	3.28	1100	90	P	
<b>Supplementary information:</b> - No fire - No explosion					



**Attachment 1**  
Equipment list  
50135052 001



www.lcs-cert.com

**Produkte**  
Products

Page 1 of 3

	Eq. No.	Name	Manufacturer	Model No.	Date of Calibration	Date of next Calibration
<input checked="" type="checkbox"/>	LCS-S-058	Data Collector	Agilent	34970A	2017/10/11	2018/10/10
<input checked="" type="checkbox"/>	LCS-S-063	Data Collector	Agilent	34970A	2017/8/19	2018/8/18
<input checked="" type="checkbox"/>	LCS-S-029	Stopwatch	Gongwen	PC396	2017/10/11	2018/10/10
<input checked="" type="checkbox"/>	LCS-S-089	Vibration Test Instrument	Dongling	ES-3-150	2017/10/11	2018/10/10
<input checked="" type="checkbox"/>	LCS-S-090	Vertical Shock Tester	Dongling	SY10-5	2017/10/11	2018/10/10
<input checked="" type="checkbox"/>	LCS-S-091	Battery Cursh Tester	Bell	BE-6045-2T	2017/10/11	2018/10/10
<input type="checkbox"/>	LCS-S-092	Battery Impact Tester	Bell	BE-5066	2017/10/11	2018/10/10
<input type="checkbox"/>	LCS-S-093	Battery Internal Short Circuit Tester	Bell	BE-6045W	2017/10/11	2018/10/10
<input checked="" type="checkbox"/>	LCS-S-094	Low Altitude Simulation Tester	Bell	BE-ZK-64	2017/10/11	2018/10/10
<input checked="" type="checkbox"/>	LCS-S-095	Battery Thermal Abuse Tester	Bell	BE-101-270B	2017/10/11	2018/10/10
<input checked="" type="checkbox"/>	LCS-S-096	Battery Short Circuit Tester	Bell	BE-1000A	2017/10/11	2018/10/10
<input type="checkbox"/>	LCS-S-097	Battery Burning Tester	Bell	BE-6046	2017/10/11	2018/10/10
<input checked="" type="checkbox"/>	LCS-S-098	Rapid Temperature Tester	Bell	BTKS-150C	2017/10/11	2018/10/10
<input checked="" type="checkbox"/>	LCS-S-099	Free Fall Tester	Bell	BF-F-315S	2017/10/11	2018/10/10
<input checked="" type="checkbox"/>	LCS-S-100	Battery Charge/Discharge Tester	Xinwei	CT-3008-5V10A-204	2017/10/11	2018/10/10
<input checked="" type="checkbox"/>	LCS-S-101	Battery Charge/Discharge Tester	Xinwei	CT-3008-5V10A-204	2017/10/11	2018/10/10
<input type="checkbox"/>	LCS-S-102	Glove Box	Etelux	Lab2000	2017/06/07	2018/06/06
<input checked="" type="checkbox"/>	LCS-S-103	Battery Charge/Discharge Tester	Xinwei	CT-3008-15V3A	2017/8/18	2018/8/17
<input checked="" type="checkbox"/>	LCS-S-104	Battery Charge/Discharge Tester	Xinwei	CT-3008-15V3A-A	2017/10/11	2018/10/10
<input type="checkbox"/>	LCS-S-105	Internal Resistance Tester	OPTEX	BTS-100	2017/10/11	2018/10/10
<input checked="" type="checkbox"/>	LCS-S-106	Digital multimeter	TES	TES2732	2017/8/18	2018/8/17
<input type="checkbox"/>	LCS-S-107	DC Power Supply	Chroma	62012P-80-60	2017/10/11	2018/10/10
<input checked="" type="checkbox"/>	LCS-S-116	Insulation Resistance Tester	Yangzi	CS2676CX-1	2017/10/11	2018/10/10

Shenzhen LCS Compliance Testing Laboratory Ltd.

1/F, Xingyuan Industrial Park, Tongda Road, Bao'an Avenue, Bao'an District, Shenzhen, Guangdong, China

**Attachment 1**  
Equipment list  
50135052 001



www.lcs-cert.com

**Produkte**  
Products

Page 2 of 3

	Eq. No.	Name	Manufacturer	Model No.	Date of Calibration	Date of next Calibration
<input checked="" type="checkbox"/>	LCS-S-126	Battery Charge/Discharge Tester	Xinwei	CT-4008-6V4A-CCDC	2017/10/11	2018/10/10
<input type="checkbox"/>	LCS-S-127	Battery Charge/Discharge Tester	Xinwei	CT-4008-50V20A-ND	2017/10/11	2018/10/10
<input checked="" type="checkbox"/>	LCS-S-168	Electronic Balance	Yingheng	5003	2017/10/11	2018/10/10
<input checked="" type="checkbox"/>	LCS-S-174	Battery Charge/Discharge Tester	Xinwei	CT-3008-5V10A-204	2017/5/8	2019/5/7
<input checked="" type="checkbox"/>	LCS-S-175	Battery Charge/Discharge Tester	Xinwei	CT-3008-5V10A-204	2017/5/8	2019/5/7
<input checked="" type="checkbox"/>	LCS-S-176	Battery Charge/Discharge Tester	Xinwei	CT-3008-10V6A-A	2017/8/24	2018/8/23
<input checked="" type="checkbox"/>	LCS-S-177	Battery Charge/Discharge Tester	Xinwei	CT-3008-10V6A-A	2017/8/18	2018/8/17
<input type="checkbox"/>	LCS-S-189	Battery Acupuncture Tester	Xiangmin	XM-ZC001	2017/10/11	2018/10/10
<input type="checkbox"/>	LCS-S-193	Battery Charge/Discharge Tester	Repower	CTS 20V-5A	2017/5/8	2019/5/7
<input type="checkbox"/>	LCS-S-199	Battery Charge/Discharge Tester	Repower	CDS60V10A	2017/5/8	2019/5/7
<input type="checkbox"/>	LCS-S-200	Battery Charge/Discharge Tester	Repower	CDS-5V100A	2017/5/8	2019/5/7

\*) Initial calibration or verification only

Shenzhen LCS Compliance Testing Laboratory Ltd.

1/F, Xingyuan Industrial Park, Tongda Road, Bao'an Avenue, Bao'an District, Shenzhen, Guangdong, China

## Attachment 1

Equipment list  
50135052 001



www.lcs-cert.com

Produkte  
Products

Page 3 of 3

### Statement of Uncertainty

Unless otherwise specified, combined measurement uncertainty for values stated in the test report is as stated below:

Voltage measurement:	±1.50% (true rms value)
	±1.20% (DC voltage)
Current measurement:	±1.56% (true rms value)
	±1.40% (DC current)
Touch current (below 30 mA)	±2.04%
Power - less than 1 W	±20 mW
- below 3 kW	±0.53%
- 3 kW and more	±0.58%
Power factor	±0.01
Frequency	±0.06%
Resistance - between 100 mΩ and 1 MΩ	±1.25%
- another values	±2.05%
Temperature- below 100°C	±1.25°C (without thermocouple; for thermocouple add 2°C)
- between 100 and 500°C	±1.45°C (without thermocouple; for thermocouple add 2°C)
Time - below 20 s	±0.74%
- more than 20 s (manual meas.)	±0.2 s
Linear dimensions - less than 1 mm	±0.01 mm
- from 1 to 25 mm	±0.05 mm
- more than 25 mm	±0.30%
Mass - below 5 kg	±2%
- 5 kg and more	±1%
Force	±1%
Torque	±3%
Angles	±12'
Relative humidity	±5%
Air pressure (barometric)	±0.2 kPa
Pressure	±3.34%
Flow	±1.5%

Values stated in this document represent the worst case for equipment which is in possession of the laboratory and setups commonly used for testing.

For units or cases not specified in this document the evaluation of uncertainty shall be made upon request on individual basis.

The reported combined uncertainty is stated as standard uncertainty of reported value multiplied by coverage factor  $k = 2$ , which for normal distribution corresponds to a coverage probability of approximately 95%.

Shenzhen LCS Compliance Testing Laboratory Ltd.

1/F, Xingyuan Industrial Park, Tongda Road, Bao'an Avenue, Bao'an District, Shenzhen, Guangdong, China

Product: Li-ion Battery  
Type Designation: BL1200P4054481S1PC\*C  
(\*=A, B, C, H, J, K, L, M, N, P, Q, R, T, U, V, 1, 2, 3, 4, 5, 6, 7, 8, 9)



Figure 1 Front view of battery (The final version of the label, see page4 of the report)

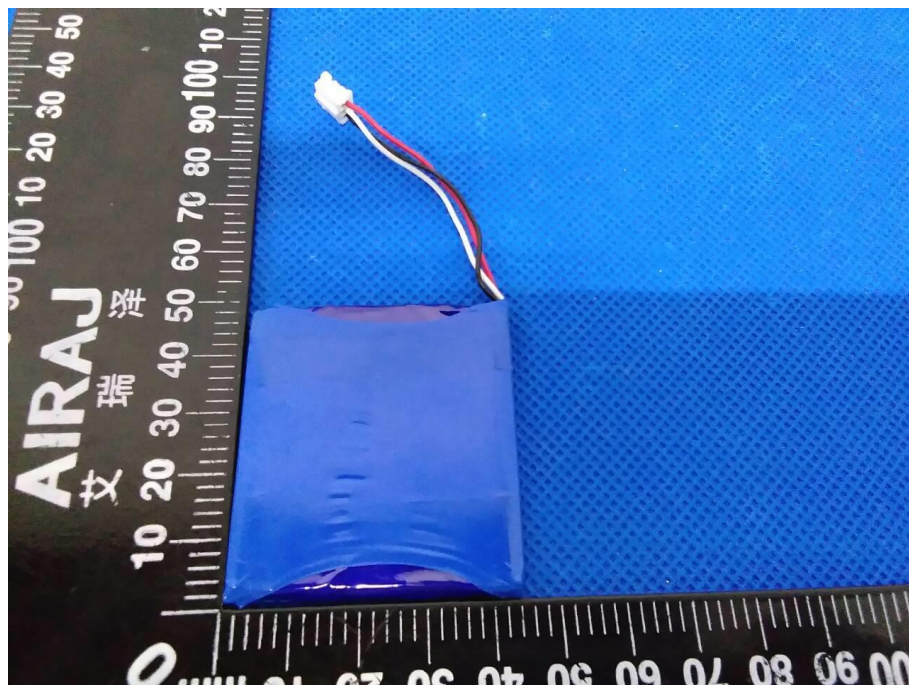

Figure 2 Back view of battery



Product: Li-ion Battery

Type Designation: BL1200P4054481S1PC\*C

(\*=A, B, C, H, J, K, L, M, N, P, Q, R, T, U, V, 1, 2, 3, 4, 5, 6, 7, 8, 9)

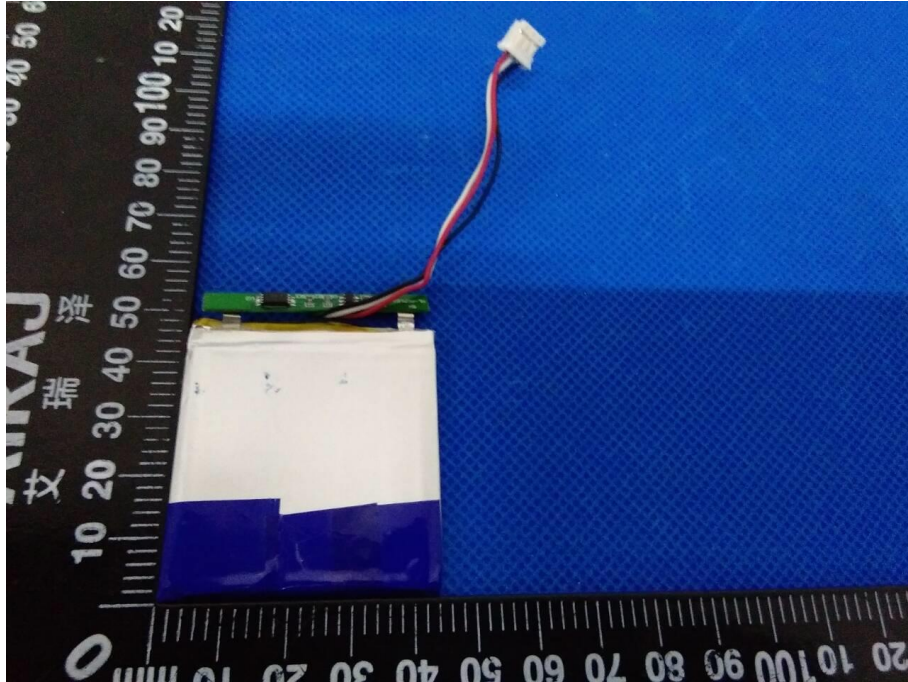

Figure 3 Inner view of battery

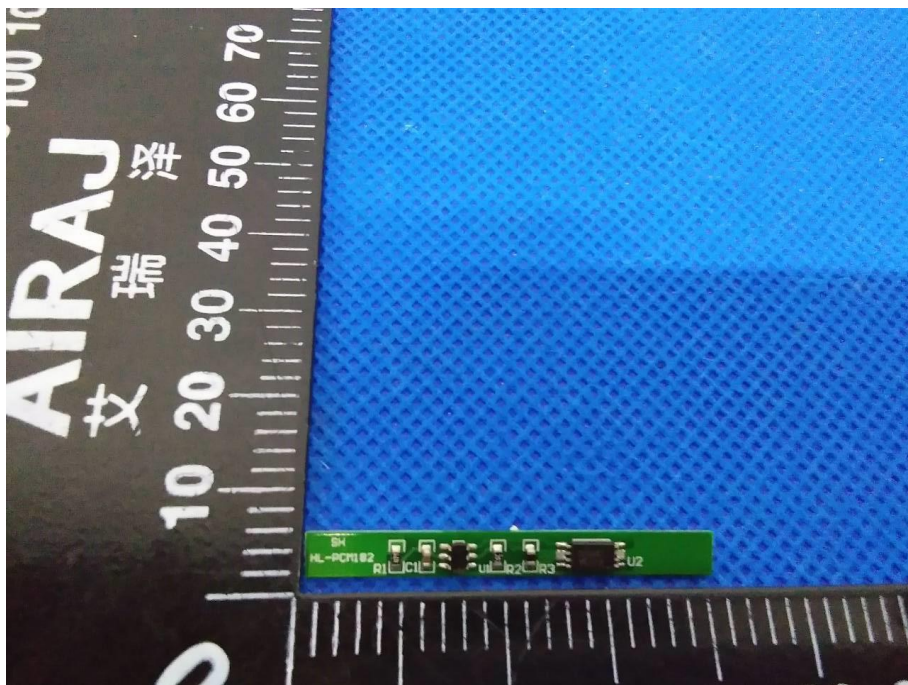

Figure 4 Front view of PCM



Product: Li-ion Battery  
Type Designation: BL1200P4054481S1PC\*C  
(\*=A, B, C, H, J, K, L, M, N, P, Q, R, T, U, V, 1, 2, 3, 4, 5, 6, 7, 8, 9)

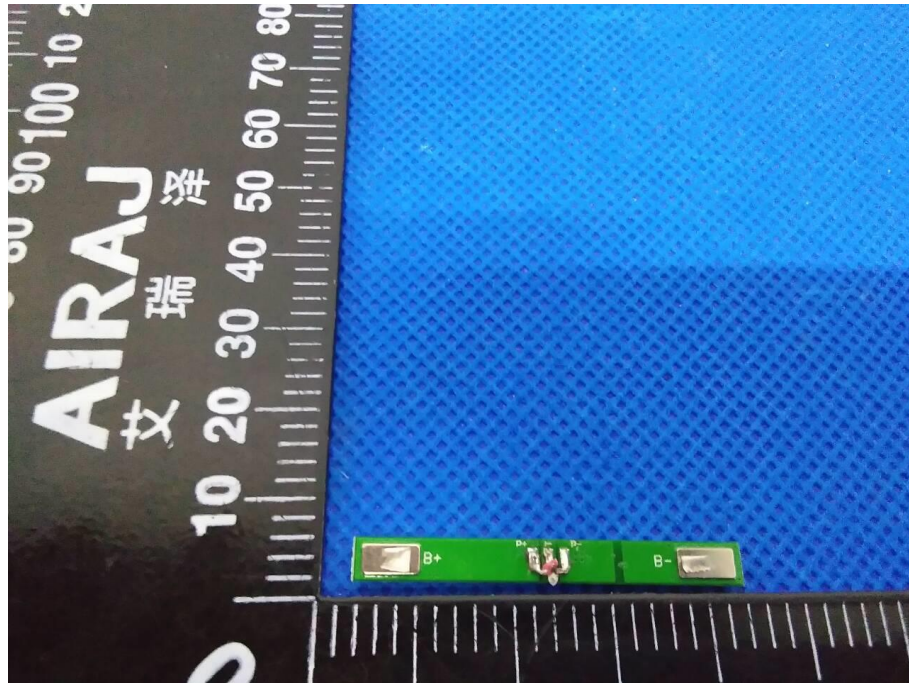

Figure 5 Back view of PCM



Figure 6 Front view of cell

Product: Li-ion Battery

Type Designation: BL1200P4054481S1PC\*C

(\*=A, B, C, H, J, K, L, M, N, P, Q, R, T, U, V, 1, 2, 3, 4, 5, 6, 7, 8, 9)

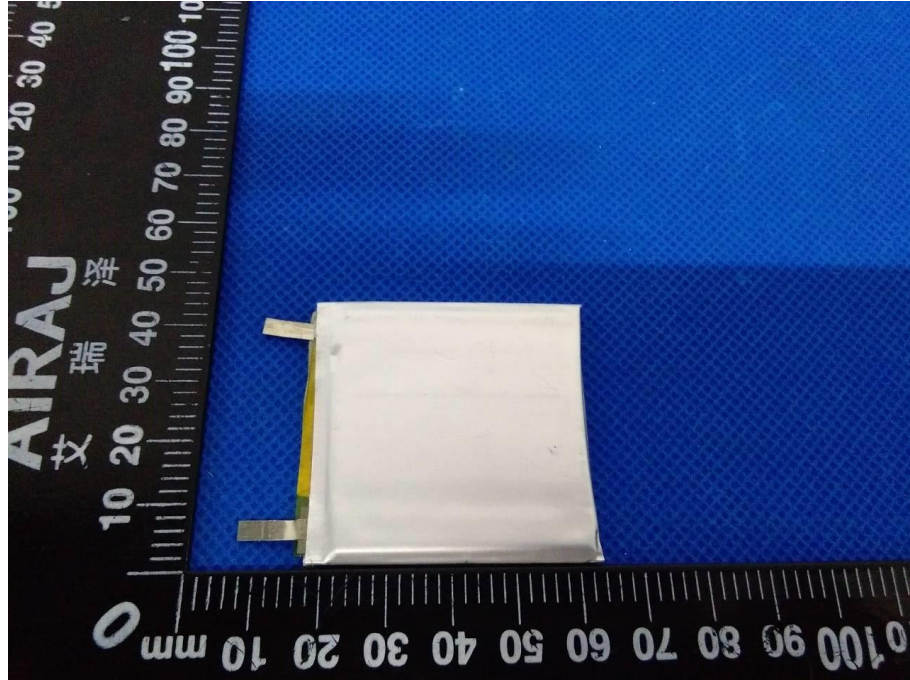

Figure 7 Back view of cell